



SOT-23 Plastic-Encapsulate Transistors

2SA1037 TRANSISTOR (PNP)

FEATURES

Power dissipation

$$P_{CM} : 0.2 \text{ W (Tamb=25°C)}$$

Collector current

$$I_{CM} : -0.15 \text{ A}$$

Collector-base voltage

$$V_{(BR)CBO} : -60 \text{ V}$$

Operating and storage junction temperature range

$$T_J, T_{stg}: -55°C \text{ to } +150°C$$

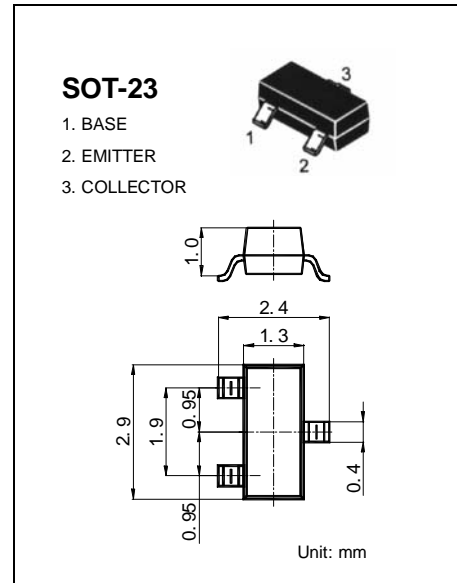

ELECTRICAL CHARACTERISTICS (Tamb=25°C unless otherwise specified)

Parameter	Symbol	Test conditions	MIN	TYP	MAX	UNIT
Collector-base breakdown voltage	$V_{(BR)CBO}$	$I_C = -50\mu A, I_E = 0$	-60			V
Collector-emitter breakdown voltage	$V_{(BR)CEO}$	$I_C = -1mA, I_B = 0$	-50			V
Emitter-base breakdown voltage	$V_{(BR)EBO}$	$I_E = -50\mu A, I_C = 0$	-6			V
Collector cut-off current	I_{CBO}	$V_{CB} = -60V, I_E = 0$			-0.1	μA
Emitter cut-off current	I_{EBO}	$V_{EB} = -6V, I_C = 0$			-0.1	μA
DC current gain	h_{FE}	$V_{CE} = -6V, I_C = -1mA$	120		560	
Collector-emitter saturation voltage	$V_{CE(sat)}$	$I_C = -50mA, I_B = -5mA$			-0.5	V
Transition frequency	f_T	$V_{CE} = -12V, I_C = -2mA$ $f = 30MHz$	120			MHz

CLASSIFICATION OF h_{FE}

Rank	Q	R	S
Range	120-270	180-390	270-560
Marking	FQ	FR	FS