

Silicon PNP Power Transistors

2SA1125

DESCRIPTION

- With TO-220 package
- Complement to type 2SC2633
- High breakdown voltage

APPLICATIONS

- For audio frequency high voltage amplifier applications

PINNING

PIN	DESCRIPTION
1	Emitter
2	Collector;connected to mounting base
3	Base

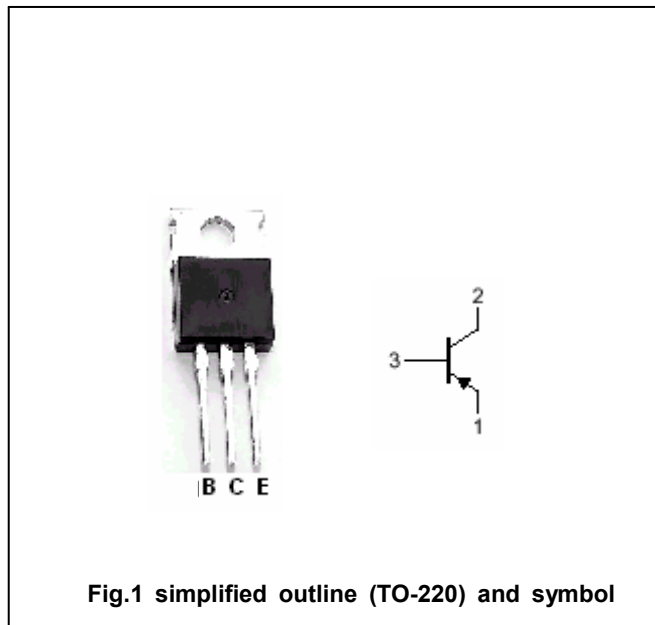

Absolute maximum ratings(Ta=25°C)

SYMBOL	PARAMETER	CONDITIONS	VALUE	UNIT
V _{CBO}	Collector-base voltage	Open emitter	-150	V
V _{CEO}	Collector-emitter voltage	Open base	-150	V
V _{EBO}	Emitter-base voltage	Open collector	-5	V
I _C	Collector current		-50	mA
I _{CM}	Collector current-peak		-100	mA
P _C	Collector power dissipation	T _C =25°C	1.5	W
T _j	Junction temperature		150	°C
T _{stg}	Storage temperature		-55~150	°C

Silicon PNP Power Transistors

2SA1125

CHARACTERISTICS

T_j=25 °C unless otherwise specified

SYMBOL	PARAMETER	CONDITIONS	MIN	TYP.	MAX	UNIT
V _{(BR)CEO}	Collector-emitter breakdown voltage	I _C =-0.1mA, I _B =0	-150			V
V _{(BR)EBO}	Emitter-base breakdown voltage	I _E =-10μA, I _C =0	-5			V
V _{CEsat}	Collector-emitter saturation voltage	I _C =-30mA; I _B =-3mA			-1.0	V
I _{CBO}	Collector cut-off current	V _{CB} =-100V; I _E =0			-1	μA
I _{EBO}	Emitter cut-off current	V _{EB} =-4V; I _C =0			-1	μA
h _{FE}	DC current gain	I _C =-10mA; V _{CE} =-5V	90		450	
C _{OB}	Output capacitance	I _E =0; V _{CB} =-10V; f=1MHz			5	pF
f _T	Transition frequency	I _C =-10mA; V _{CE} =-10V		200		MHz

◆ h_{FE} Classifications

Q	R	S	T
90-155	130-220	185-330	260-450

Silicon PNP Power Transistors

2SA1125

PACKAGE OUTLINE

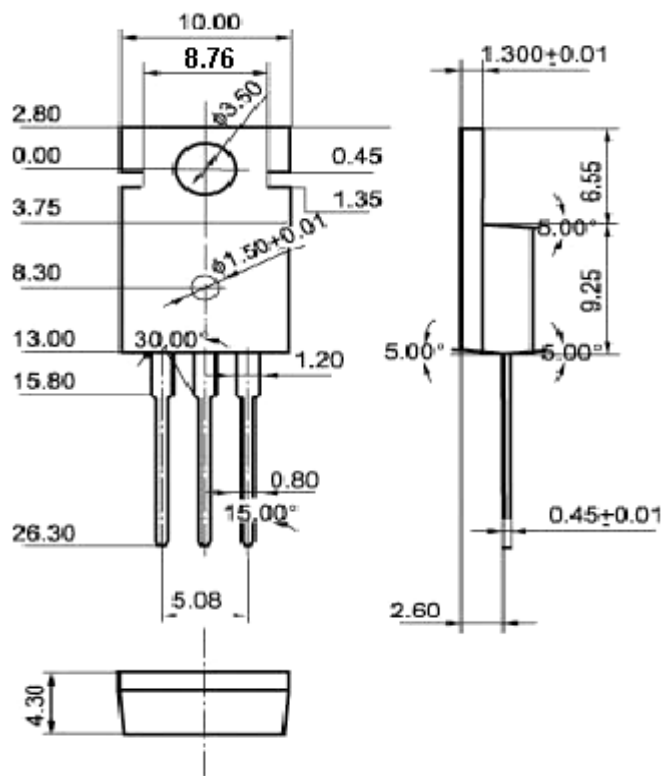

Fig.2 Outline dimensions(unindicated tolerance:±0.10 mm)