

## Silicon Planar Epitaxial Transistor

2SA1203

### FEATURES

- Suitable for output stage of 3 watts amplifier
- Suitable flat package
- $P_C=1.0$  to  $2.0W$ (mounted on ceramic substrate)
- Complementary to 2SC2883

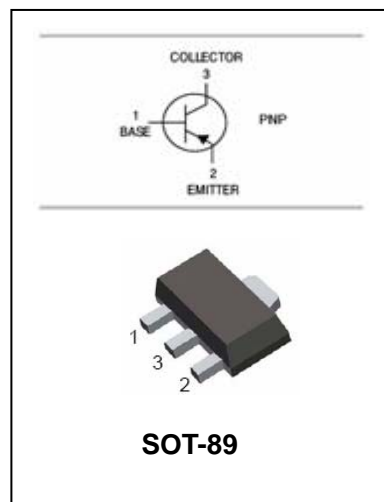

### ORDERING INFORMATION

Type No.	Marking	Package Code
2SA1203	HO1/HY1	SOT-89

### MAXIMUM RATING @ $T_a=25^{\circ}C$ unless otherwise specified

Symbol	Parameter	Value	Units
$V_{CBO}$	Collector-Base Voltage	-30	V
$V_{CEO}$	Collector-Emitter Voltage	-30	V
$V_{EBO}$	Emitter-Base Voltage	-5	V
$I_C$	Collector Current	-1.5	A
$I_B$	Base Current	-0.3	A
$P_C$	Collector Dissipation	500 1000(Note 1)	mW
$T_j, T_{stg}$	Junction and Storage Temperature	-55 to +150	$^{\circ}C$

Note1: Mounted on ceramic substrate( $250mm^2 \times 0.8t$ )



Silicon Planar Epitaxial Transistor

2SA1203

ELECTRICAL CHARACTERISTICS @ Ta=25°C unless otherwise specified

Parameter	Symbol	Test conditions	MIN	TYP	MAX	UNIT
Collector-emitter breakdown voltage	$V_{(BR)CEO}$	$I_C=-10mA, I_B=0$	-30			V
Emitter-base breakdown voltage	$V_{(BR)EBO}$	$I_E=-1mA, I_C=0$	-5			V
Collector cut-off current	$I_{CBO}$	$V_{CB}=-30V, I_E=0$			-0.1	$\mu A$
Emitter cut-off current	$I_{EBO}$	$V_{EB}=-5V, I_C=0$			-0.1	$\mu A$
DC current gain	$h_{FE}$	$V_{CE}=-2V, I_C=-500mA$	100		320	
Collector-emitter saturation voltage	$V_{CE(sat)}$	$I_C=-1.5A, I_B=-0.03A$			-2	V
Base-emitter	$V_{BE}$	$V_{CE}=-2V, I_C=-500mA$			-1	
Transition frequency	$f_T$	$V_{CE}=-2V, I_C=-500mA$		120		MHz
Collector output capacitance	$C_{ob}$	$V_{CB}=-10V, I_E=0, f=1MHz$			50	pF

CLASSIFICATION OF  $h_{FE}$

Rank	O	Y
Range	100-200	160-320
Marking	HO1	HY1



Silicon Planar Epitaxial Transistor

2SA1203

TYPICAL CHARACTERISTICS @ Ta=25°C unless otherwise specified

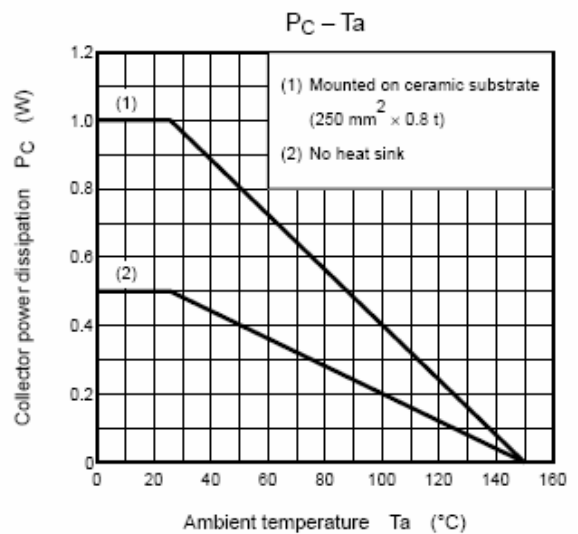
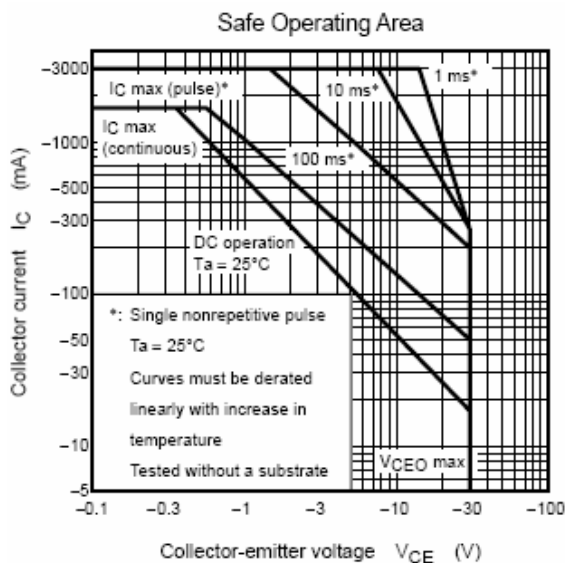
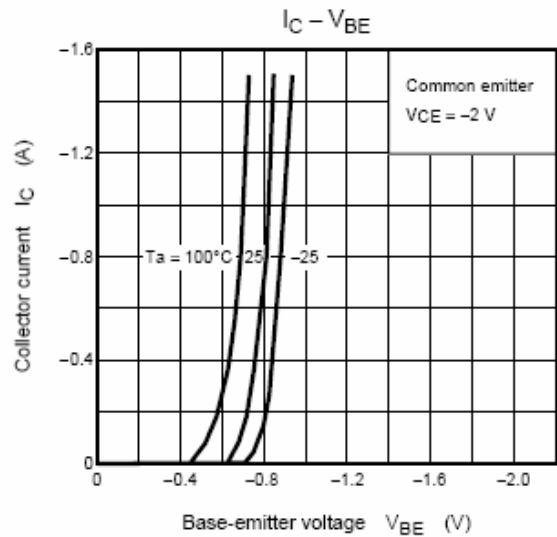
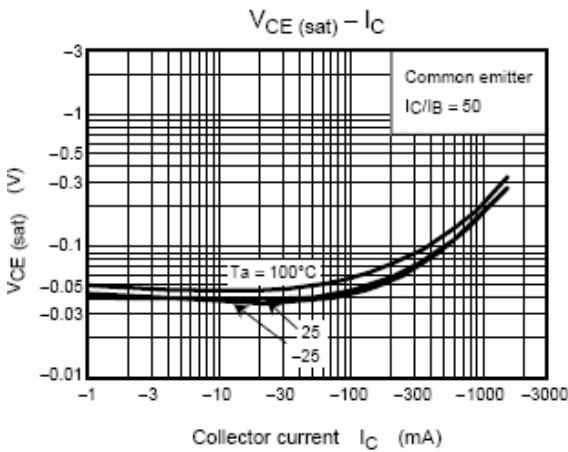
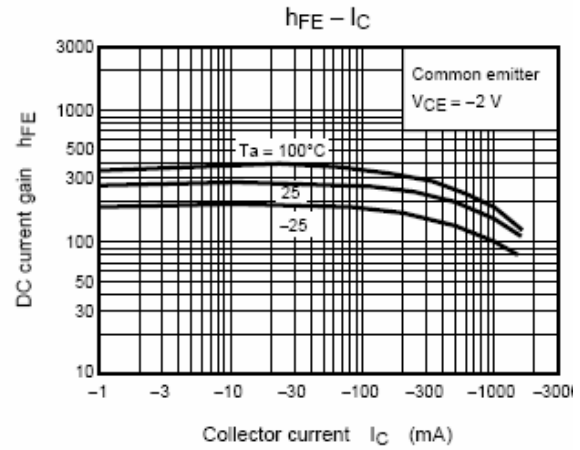
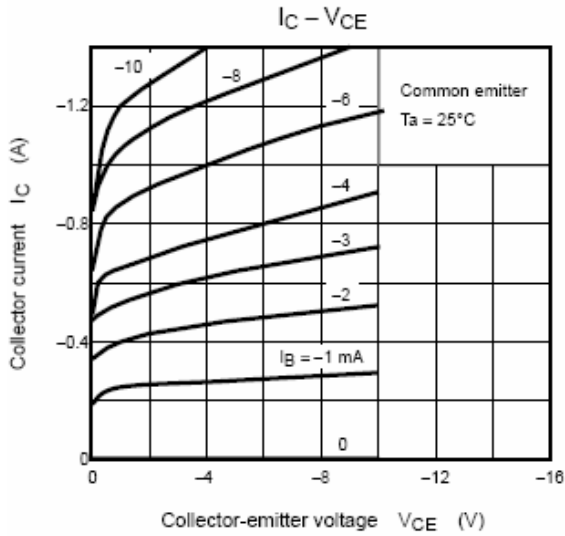



Silicon Planar Epitaxial Transistor

2SA1203

PACKAGE OUTLINE

Plastic surface mounted package

SOT-89

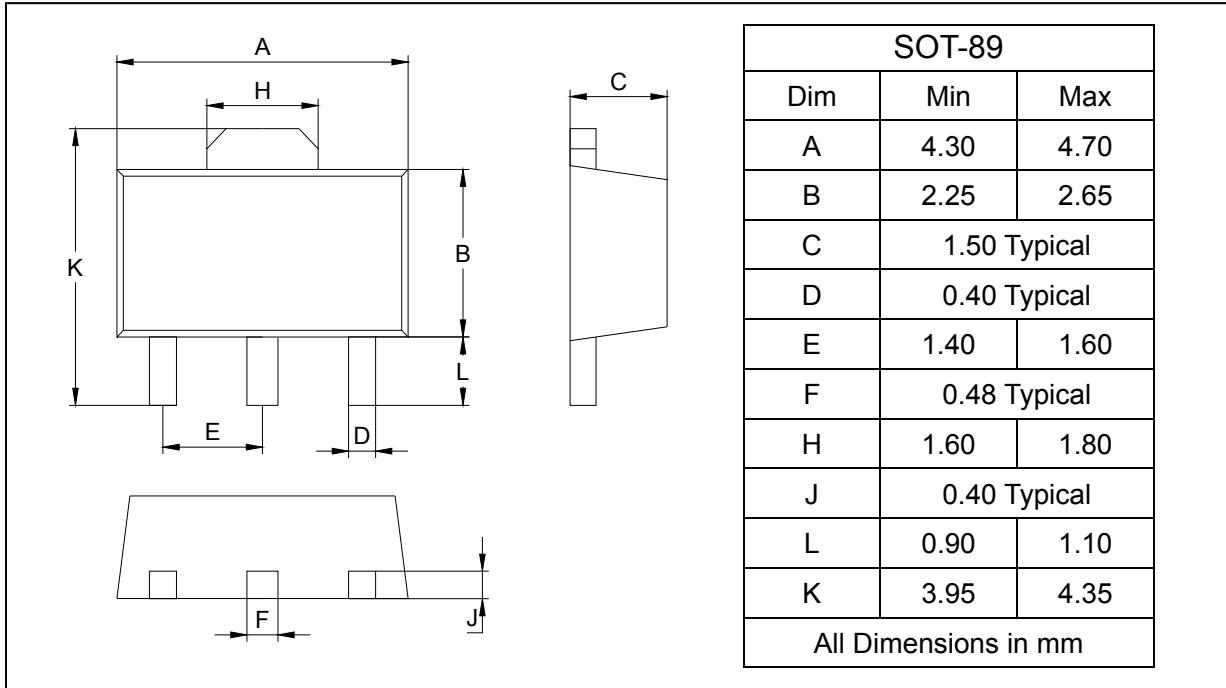

SOLDERING FOOTPRINT

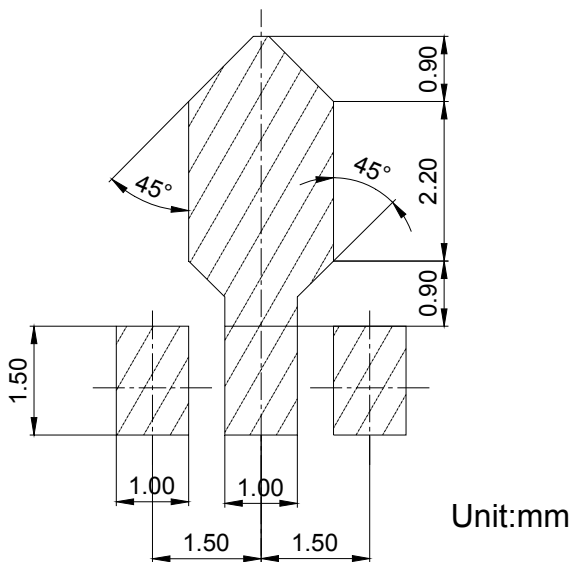

PACKAGE INFORMATION

Device	Package	Shipping
2SA1203	SOT-89	1000/Tape&Reel