

2SA1205

Silicon PNP Epitaxial Planar

Application Example :
General Purpose

- Outline Drawing 2.....MT-10(TO3P)
- Test Circuit①

Absolute Maximum Ratings

Symbol	2SA1205	Unit
V _{CB0}	-70	V
V _{CEO}	-50	V
V _{EB0}	-6	V
I _c	-12	A
I _B	-4	A
P _c	100 (T _{FL} = 25°C)	W
T _J	150	°C
T _{stg}	-55~+150	°C

Electrical Characteristics

Symbol	Conditions	2SA1205	Unit
I _{CB0}	V _{CB} = -70V	-100max	μA
I _{EB0}	V _{EB} = -6V	-100max	μA
V _{(BR)CEO}	I _c = -25mA	-50min	V
h _{FE}	V _{CE} = -0.5V, I _c = -5A	40min	
V _{CE(sat)}	I _c = -5A, I _B = -0.12A	-0.5max	V
f _T	V _{CE} = -12V, I _E = 3A	20typ	MHz

Typical Switching Characteristics (Emitter Common)

V _{CC} (V)	R _L (Ω)	I _c (A)	V _{B2} (V)	I _{B1} (mA)	I _{B2} (mA)	t _{on} (μs)	t _{stg} (μs)	t _r (μs)
-20	4	-5	5	-120	120	0.6typ	0.5typ	0.25typ

Common Emitter Characteristics (Typical Value)

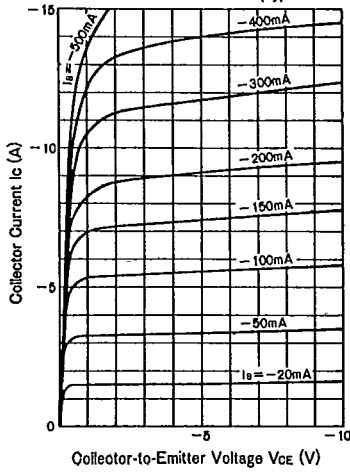

Power Derating

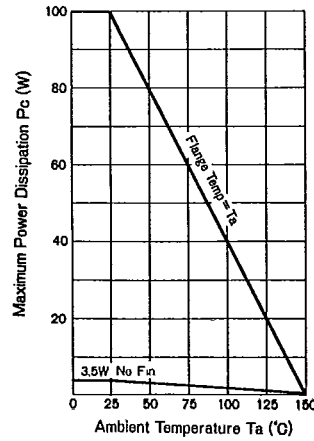

Temperature Characteristics (V_{CE} = -0.5V Const.)

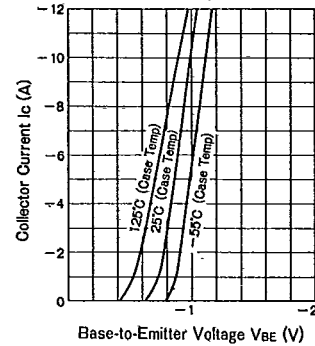

DC Current Gain Characteristics (V_{CE} = -0.5V Const.)

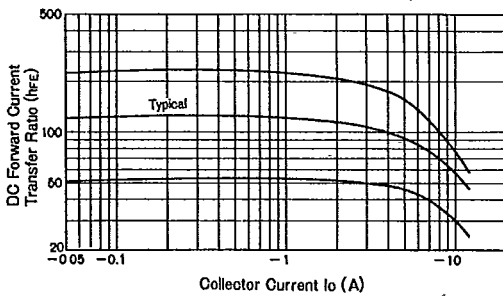

Maximum Areas For Safe Operation (ASO) (Single Pulse)

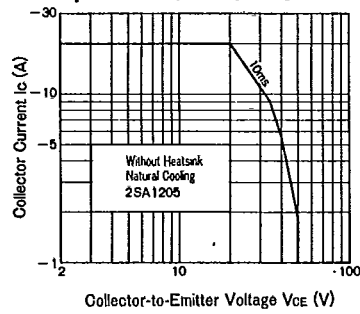

Collector-to-Emitter Saturation Characteristics (Typical Value)

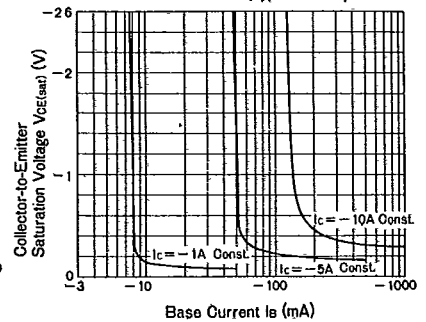

DC Current Gain Temperature Characteristics (V_{CE} = -0.5V Const.)

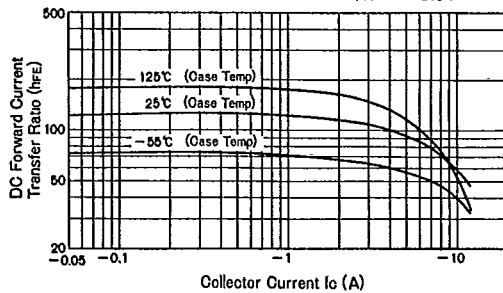

Outline Drawings/Accessories

Outline Drawing

- Flammability: UL94V-0 or equivalent
- Unit: in mm

Outline Drawings 1

MT-25(TO220)

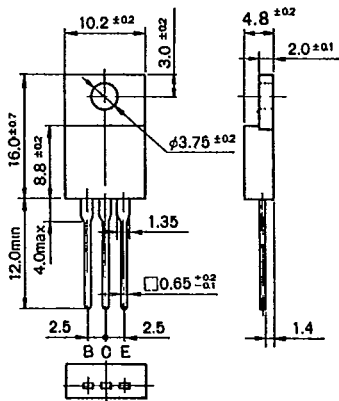

Weight: Approx. 2.6 g

Outline Drawings 2

MT-100(TO3P)

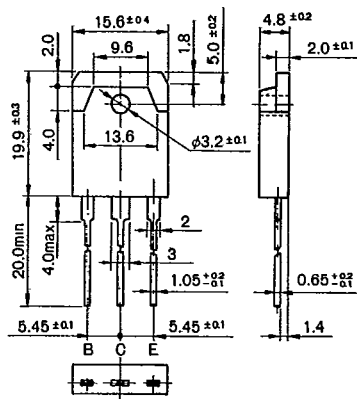

Weight: Approx. 6.0 g

Outline Drawings 3

MT-200

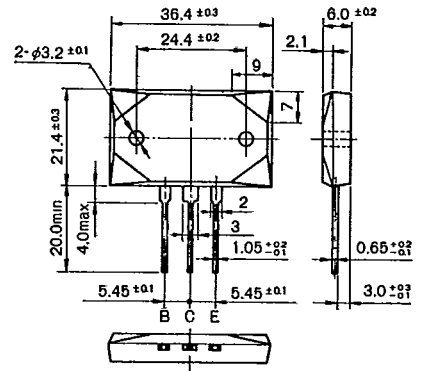

Weight: Approx. 18.4 g

Outline Drawings 4

FM20

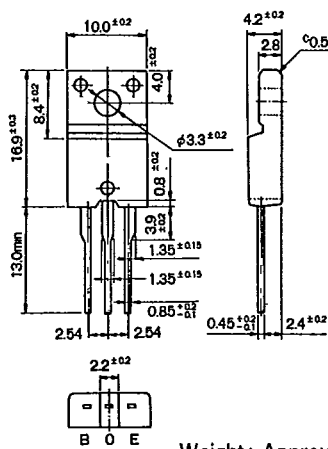

Weight: Approx. 2.0 g

Outline Drawings 5

FM100

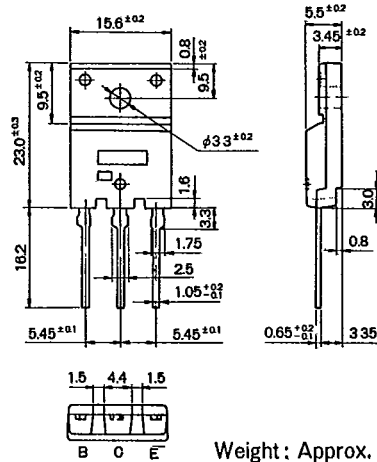

Weight: Approx. 6.5 g

Accessories

☆Sanken Transistors do not include accessories. Accessories may be attached at a cost if requested.

- Insulator: Mica, $t = 0.06^{+0.045}_{-0.005}$ mm

Type: MT-25 Mica (10)

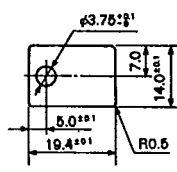

Type: MT-100 Mica (14)

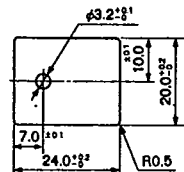

Type: MT-200 Mica (9)

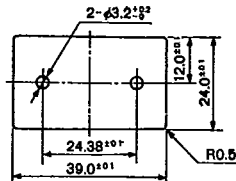

- Insulation Bush for MT-25 (TO220)

