

2SA1217

SILICON PNP EPITAXIAL TYPE (PCT PROCESS)

AUDIO FREQUENCY POWER AMPLIFIER

LOW SPEED SWITCHING

FEATURES:

- . Suitable for output stage of 5 watts car radio and car stereo.
- . Good linearity of h_{FE} .
- . Complementary to 2SC2877.

MAXIMUM RATINGS ($T_a=25^{\circ}\text{C}$)

CHARACTERISTIC	SYMBOL	RATING	UNIT
Collector-Base Voltage	V_{CB0}	-40	V
Collector-Emitter Voltage	V_{CE0}	-40	V
Emitter-Base Voltage	V_{EB0}	-5	V
Collector Current	I_C	-3	A
Base Current	I_B	-1	A
Collector Power Dissipation ($T_c=25^{\circ}\text{C}$)	P_C	10	W
Junction Temperature	T_j	150	$^{\circ}\text{C}$
Storage Temperature Range	T_{stg}	-55 ~ 150	$^{\circ}\text{C}$

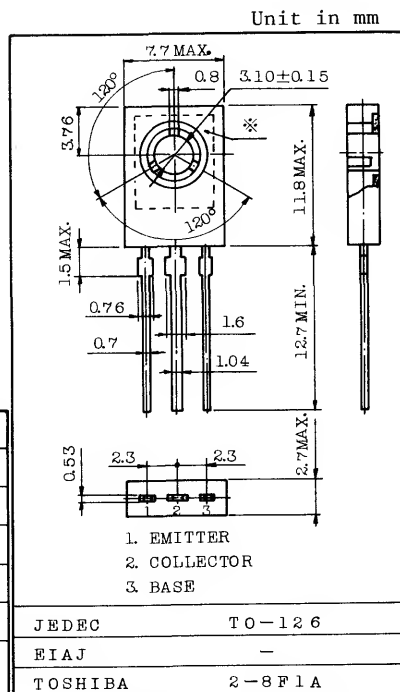

The inside metal of dotted line is connected to collector lead. Weight 0.72 g

ELECTRICAL CHARACTERISTICS ($T_a=25^{\circ}\text{C}$)

CHARACTERISTIC	SYMBOL	TEST CONDITION	MIN.	TYP.	MAX.	UNIT
Collector Cutoff Current	I_{CBO}	$V_{CB}=-40\text{V}, I_E=0$	-	-	-100	nA
Emitter Cutoff Current	I_{EBO}	$V_{EB}=-5\text{V}, I_C=0$	-	-	-100	nA
Collector-Emitter Breakdown Voltage	$V_{(BR)CEO}$	$I_C=-10\text{mA}, I_B=0$	-40	-	-	V
D.C Current Gain	$h_{FE(1)}$ (Note)	$V_{CE}=-2\text{V}, I_C=-0.5\text{A}$	80	-	240	
	$h_{FE(2)}$	$V_{CE}=-2\text{V}, I_C=-2.5\text{A}$	25	-	-	
Collector Emitter Saturation Voltage	$V_{CE(sat)}$	$I_C=-2\text{A}, I_B=-0.2\text{A}$	-	-	-0.8	V
Base-Emitter Voltage	V_{BE}	$V_{CE}=-2\text{V}, I_C=-0.5\text{A}$	-	-	-1.0	V
Transition Frequency	f_T	$V_{CE}=-2\text{V}, I_C=-0.5\text{A}$	-	100	-	MHz
Output Capacitance	C_{ob}	$V_{CB}=-10\text{V}, I_E=0, f=1\text{MHz}$	-	35	-	pF

Note: h_{FE} Classification. 0 : 80 ~ 160 Y : 120 ~ 240

