

isc Silicon PNP Power Transistor
2SA1289
DESCRIPTION

- Low Collector Saturation Voltage-
: $V_{CE(sat)} = -0.4V(\text{Max.}) @ I_C = -2.5A$
- Fast Switching Speed
- Complement to Type 2SC3253
- Minimum Lot-to-Lot variations for robust device performance and reliable operation

APPLICATIONS

- Various inductance lamp drivers for electrical equipment.
- Inverters, converters(strobo, flash, fluorescent lamp lighting circuits).
- Power amplifier (high power car stereo, motor controller).
- High-speed switching (switching regulator, driver).

ABSOLUTE MAXIMUM RATINGS($T_a=25^\circ\text{C}$)

SYMBOL	PARAMETER	VALUE	UNIT
V_{CBO}	Collector-Base Voltage	-80	V
V_{CEO}	Collector-Emmitter Voltage	-60	V
V_{EBO}	Emmitter-Base Voltage	-5	V
I_C	Collector Current-Continuous	-5	A
I_{CM}	Collector Current-Peak	-7	A
P_C	Collector Power Dissipation @ $T_C=25^\circ\text{C}$	30	W
T_J	Junction Temperature	150	$^\circ\text{C}$
T_{stg}	Storage Temperature Range	-55~150	$^\circ\text{C}$

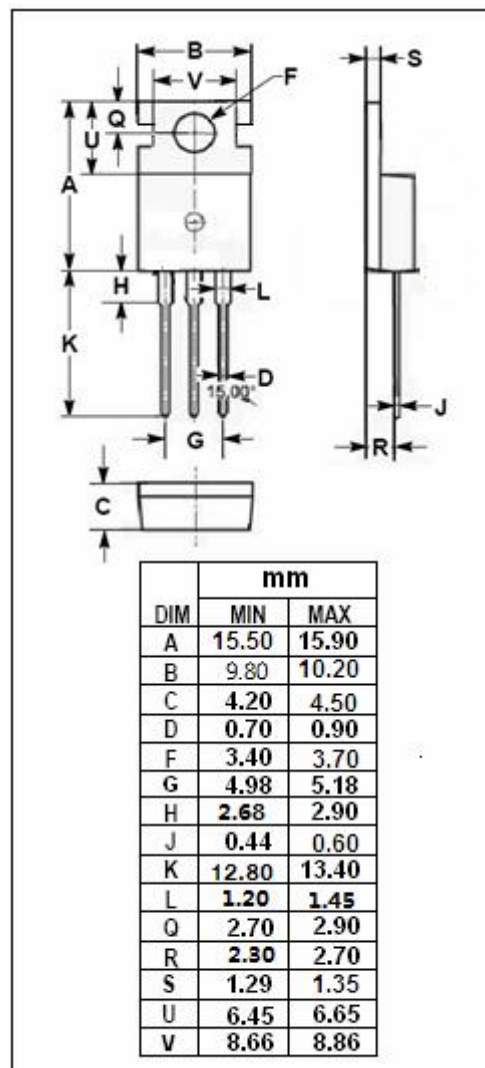
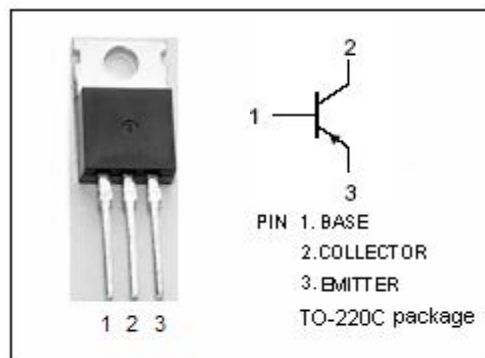

isc Silicon PNP Power Transistor
2SA1289
ELECTRICAL CHARACTERISTICS

 T_C=25°C unless otherwise specified

SYMBOL	PARAMETER	CONDITIONS	MIN	TYP.	MAX	UNIT
V _{(BR)CEO}	Collector-Emitter Breakdown Voltage	I _C = -10mA; R _{BE} = ∞	-60			V
V _{(BR)CBO}	Collector-Base Breakdown Voltage	I _C = -1mA; I _E = 0	-80			V
V _{(BR)EBO}	Emitter-Base Breakdown Voltage	I _E = -1mA; I _C = 0	-5			V
V _{CE(sat)}	Collector-Emitter Saturation Voltage	I _C = -2.5A; I _B = -0.125A			-0.4	V
I _{CBO}	Collector Cutoff Current	V _{CB} = -40V; I _E = 0			-100	μ A
I _{EBO}	Emitter Cutoff Current	V _{EB} = -4V; I _C = 0			-100	μ A
h _{FE}	DC Current Gain	I _C = -1A; V _{CE} = -2V	70		280	
f _T	Current-Gain—Bandwidth Product	I _C = -1A; V _{CE} = -5V		100		MHz

◆ h_{FE} Classifications

Q	R	S
70-140	100-200	140-280

NOTICE:

ISC reserves the rights to make changes of the content herein the datasheet at any time without notification. The information contained herein is presented only as a guide for the applications of our products.

ISC products are intended for usage in general electronic equipment. The products are not designed for use in equipment which require specialized quality and/or reliability, or in equipment which could have applications in hazardous environments, aerospace industry, or medical field. Please contact us if you intend our products to be used in these special applications.

ISC makes no warranty or guarantee regarding the suitability of its products for any particular purpose, nor does ISC assume any liability arising from the application or use of any products, and specifically disclaims any and all liability, including without limitation special, consequential or incidental damages.