

2SA1418

■ Features

- Adoption of FBET, MBIT Processes
- High Breakdown Voltage and Large Current Capacity
- Fast Switching Speed

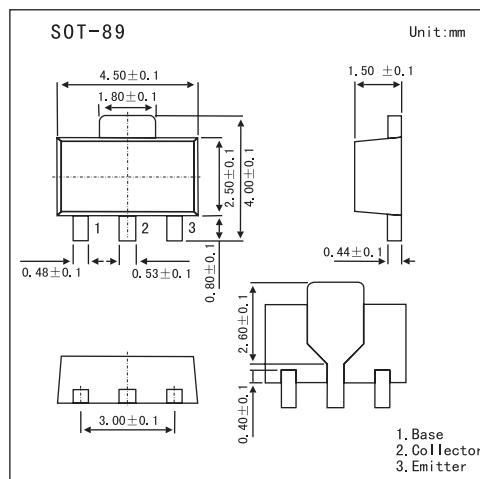

■ Absolute Maximum Ratings Ta = 25°C

Parameter	Symbol	Rating	Unit
Collector-Base Voltage	V _{CB0}	-180	V
Collector-Emitter Voltage	V _{CEO}	-160	V
Emitter-Base Voltage	V _{EBO}	-6	V
Collector Current	I _C	-0.7	A
Collector Current (Pulse)	I _{CP}	-1.5	A
Collector Power Dissipation	P _C	500	mW
	P _C *	1.3	W
Junction temperature	T _j	150	°C
Storage temperature Range	T _{stg}	-55 to +150	°C

* Mounted on ceramic board (250 mm² x 0.8 mm)

■ Electrical Characteristics Ta = 25°C

Parameter	Symbol	Testconditions	Min	Typ	Max	Unit
Collector Cut-off Current	I _{CBO}	V _{CB} = -120V, I _E = 0			-0.1	uA
Emitter Cut-off Current	I _{EBO}	V _{EB} = -4V, I _C = 0			-0.1	uA
Collector-Base Breakdown Voltage	V _{(BR)CBO}	I _C = -10uA, I _E = 0	-180			V
Collector-Emitter Breakdown Voltage	V _{(BR)CEO}	I _C = -1mA, R _{BE} = ∞	-160			V
Emitter-Base Breakdown Voltage	V _{(BR)EBO}	I _E = -10uA, I _C = 0	-6			V
DC Current Gain	h _{FE}	V _{CE} = -5V, I _C = -100mA	100		400	
Collector-Emitter Saturation Voltage	V _{CE(sat)}	I _C = -250mA, I _B = -25mA		-0.2	-0.5	V
Base-Emitter Saturation Voltage	V _{BE(sat)}	I _C = -250mA, I _B = -25mA		-0.85	-1.2	V
Gain-Bandwidth Product	f _T	V _{CE} = -10V, I _C = -50mA		120		MHz
Collector Output Capacitance	C _{ob}	V _{CB} = -10V, I _E = 0, f = 1MHz		11		pF
Turn-On Time	t _{on}	See Test Circuit.		60		ns
Storage Time	t _{stg}			900		
Fall Time	t _f			60		

2SA1418

Test Circuit

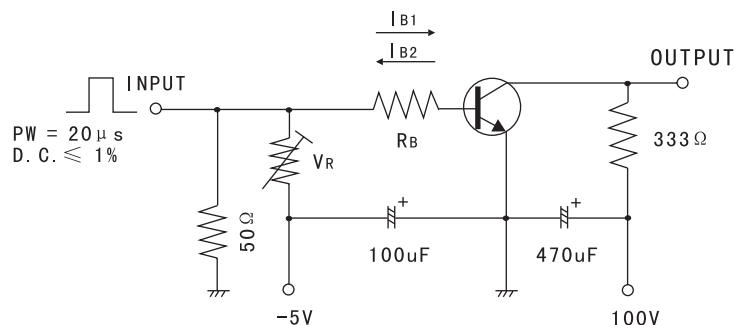

$20I_{B1} = -20I_{B2} = I_C = 300\text{mA}$
 (For PNP, the polarity is reversed.)

hFE Classification

Marking	AD		
Rank	R	S	T
hFE	100 ~ 200	140 ~ 280	200 ~ 400

Electrical Characteristics Curves

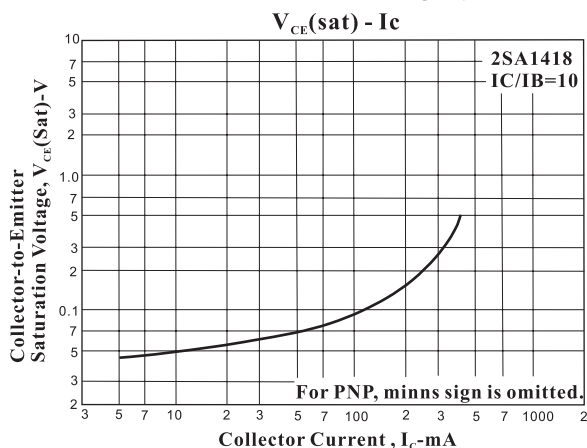
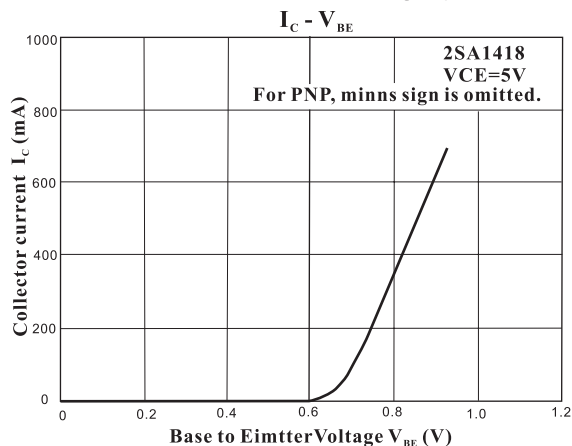
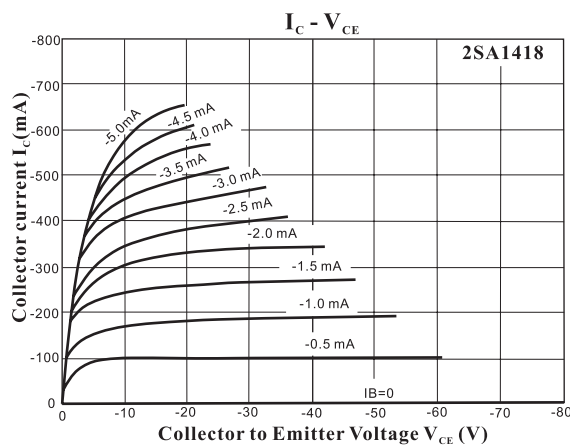
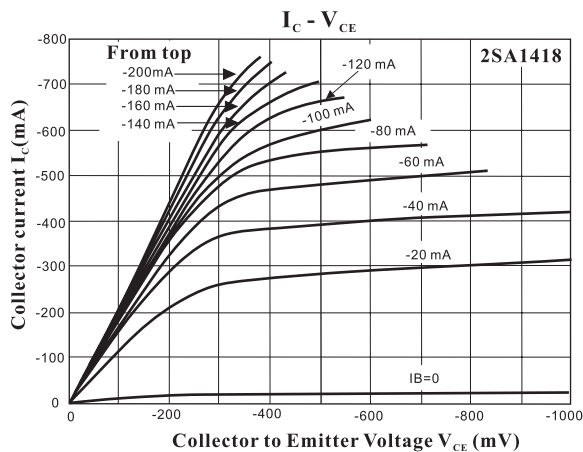



2SA1418

