

General Purpose Transistor

2SA1576A

■ Features

- Excellent hFE linearity.

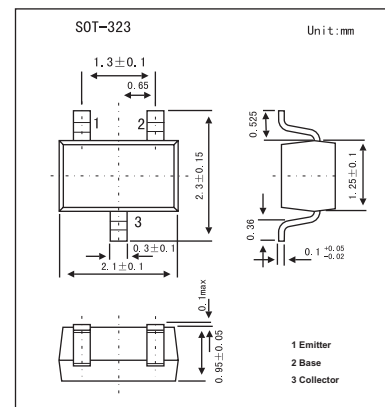

■ Absolute Maximum Ratings Ta = 25°C

Parameter	Symbol	Rating	Unit
Collector-base voltage	V _{CB0}	-60	V
Collector-emitter voltage	V _{CEO}	-50	V
Emitter-base voltage	V _{EBO}	-6	V
Collector current	I _C	-0.15	A
Collector power dissipation	P _C	0.2	W
Junction temperature	T _J	150	°C
Storage temperature	T _{stg}	-55 to +150	°C

■ Electrical Characteristics Ta = 25°C

Parameter	Symbol	Testconditions	Min	Typ	Max	Unit
Collector-base breakdown voltage	BV _{CB0}	I _C =-50μA	-60			V
Collector-emitter breakdown voltage	BV _{CEO}	I _C =-1mA	-50			V
Emitter-base breakdown voltage	BV _{EBO}	I _E =-50μA	-6			V
Collector cutoff current	I _{CBO}	V _{CB} =-60V			-0.1	μA
Emitter cutoff current	I _{EBO}	V _{EB} =-6V			-0.1	μA
Collector-emitter saturation voltage	V _{CE(sat)}	I _C /I _B =-50mA/-5mA			-0.5	V
DC current transfer ratio	h _{FE}	V _{CE} =-6V, I _C =-1mA	120		560	
Transition frequency	f _T	V _{CE} =-12V, I _E =2mA, f=30MHz		140		MHz
Output capacitance	C _{ob}	V _{CB} =-12V, I _E =0A, f=1MHz		4.0	5.0	pF

■ hFE Classification

Marking	FQ	FR	FS
hFE	120~270	180~390	270~560