

PNP Epitaxial Planar Silicon Transistor

2SA1740

FEATURES

- High breakdown voltage.
- Adoption of MBIT process.
- Excellent h_{FE} linearity.

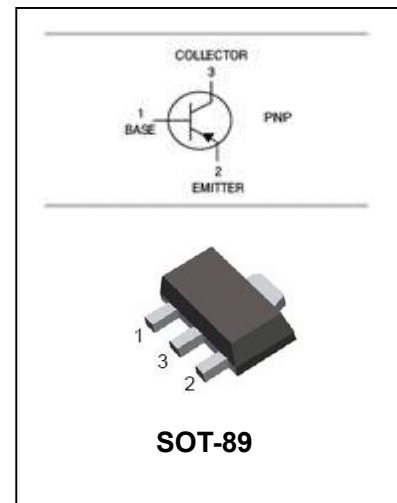

APPLICATIONS

- High-Voltage Driver Applications

ORDERING INFORMATION

Type No.	Marking	Package Code
2SA1740	AK	SOT-89

MAXIMUM RATING @ $T_a=25^{\circ}\text{C}$ unless otherwise specified

Symbol	Parameter	Value	Units
V_{CBO}	Collector-Base Voltage	-400	V
V_{CEO}	Collector-Emitter Voltage	-400	V
V_{EBO}	Emitter-Base Voltage	-5	V
I_C	Collector Current	-200	mA
I_{CP}	Collector Current(Pulse)	-400	mA
P_C	Collector Dissipation	0.5	W
		1.3 Note1	W
T_j, T_{stg}	Junction and Storage Temperature	-55 to +150	$^{\circ}\text{C}$

Note1: Mounted on ceramic substrate(250mm²*0.8t)

PNP Epitaxial Planar Silicon Transistor

2SA1740

ELECTRICAL CHARACTERISTICS @ Ta=25°C unless otherwise specified

Parameter	Symbol	Test conditions	MIN	TYP	MAX	UNIT
Collector-base breakdown voltage	$V_{(BR)CBO}$	$I_C=-10\mu A, I_E=0$	-400			V
Collector- emitter breakdown voltage	$V_{(BR)CEO}$	$I_C=-1mA, I_B=0$	-400			V
Emitter- base breakdown voltage	$V_{(BR)EBO}$	$I_E=-10\mu A, I_C=0$	-5			V
Collector cut-off current	I_{CBO}	$V_{CB}=-300V, I_E=0$			-0.1	μA
Emitter cut-off current	I_{EBO}	$V_{EB}=-4V, I_C=0$			-0.1	μA
DC current gain	h_{FE}	$V_{CE}=-10V, I_C=-50mA$	60		200	
Base-emitter saturation voltage	$V_{BE(sat)}$	$I_C=-50mA, I_B=-5mA$			-1	V
Collector-emitter saturation voltage	$V_{CE(sat)}$	$I_C=-50mA, I_B=-5mA$			-0.8	V
Transition frequency	f_T	$V_{CE}=-30V, I_C=-10mA$		70		MHz
Output capacitance	C_{ob}	$V_{CB}=-30V, I_E=0, f=1MHz$		4		pF
Reverse Transfer Capacitance	C_{re}	$V_{CB}=-30V, I_E=0, f=1MHz$		3		pF
Turn-ON Time	t_{on}	$V_{CC}=-150V, I_C=-50mA,$ $I_{B1}=I_{B2}=-5mA$		0.25		μS
Turn-OFF Time	t_{off}			5		μS

CLASSIFICATION OF h_{FE}

Rank	D	E
Range	60-120	100-200

PNP Epitaxial Planar Silicon Transistor

2SA1740

TYPICAL CHARACTERISTICS @ $T_a=25^\circ\text{C}$ unless otherwise specified

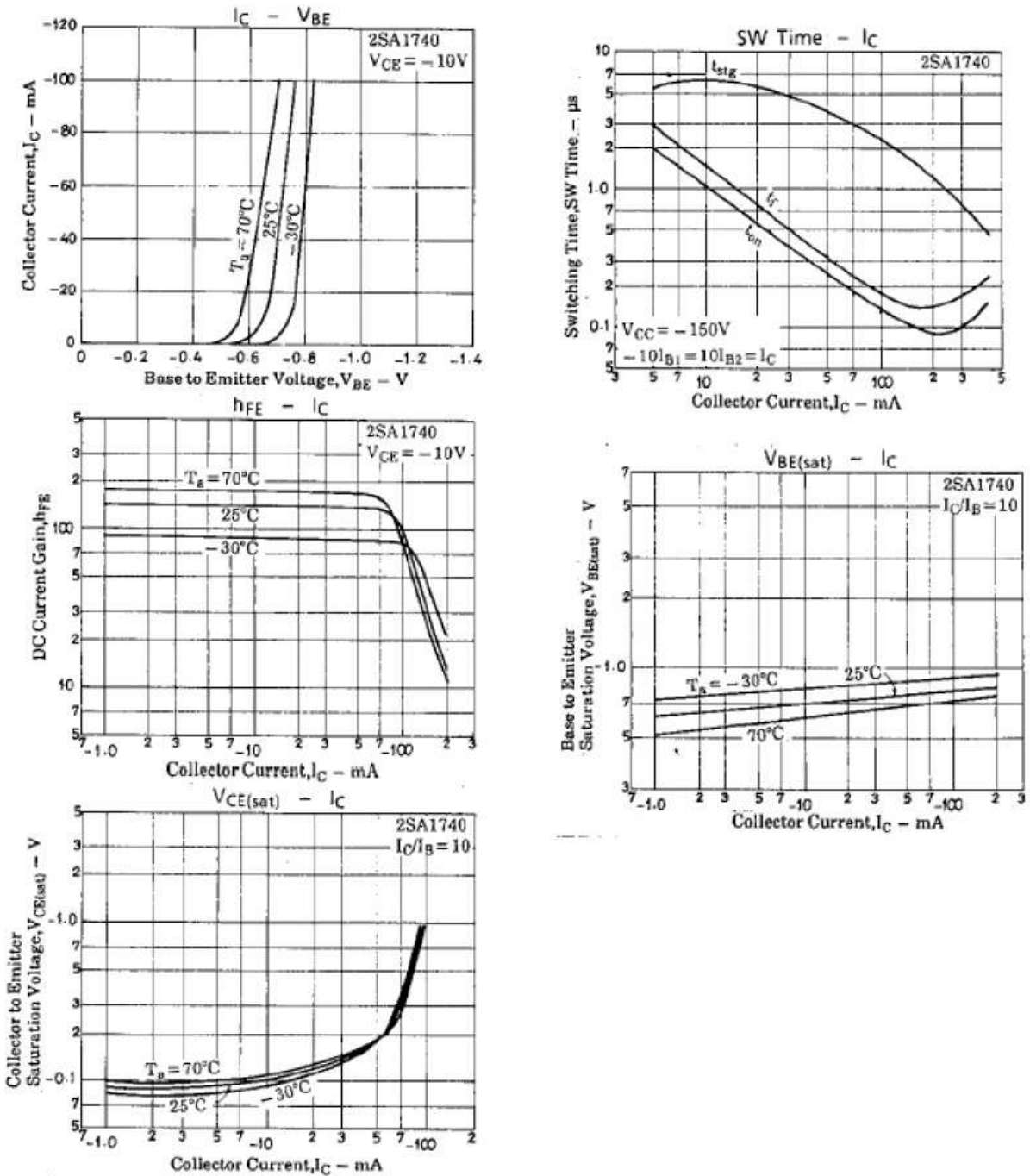

PNP Epitaxial Planar Silicon Transistor

2SA1740

PACKAGE OUTLINE

Plastic surface mounted package

SOT-89

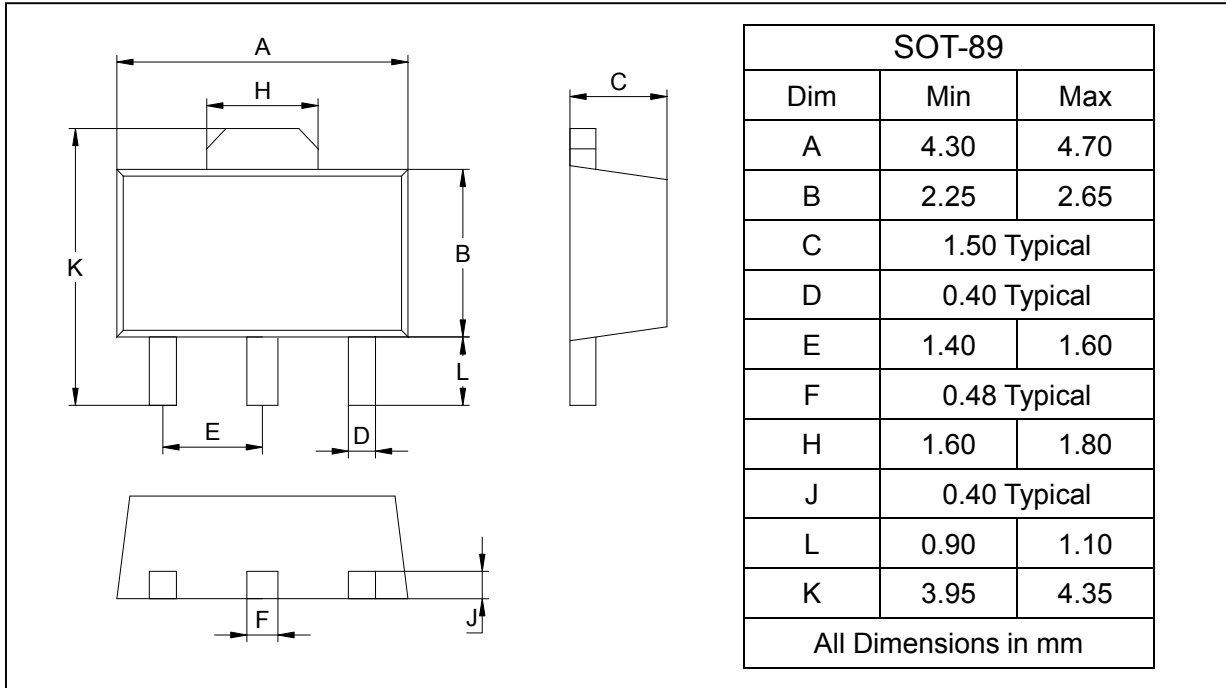

SOLDERING FOOTPRINT

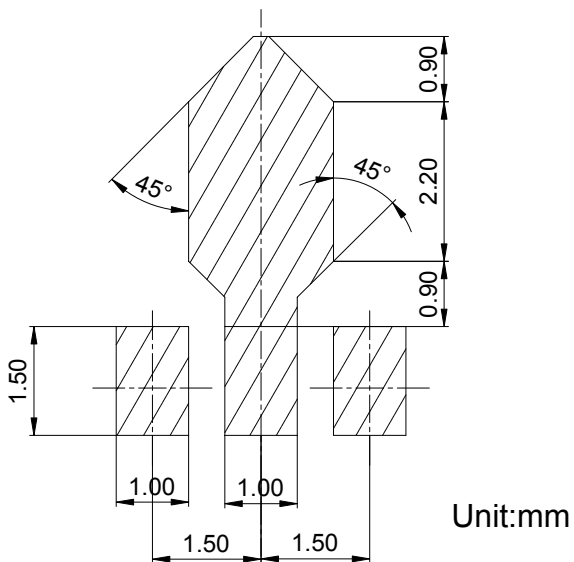

PACKAGE INFORMATION

Device	Package	Shipping
2SA1740	SOT-89	1000/Tape&Reel