

PNP Epitaxial Planar Silicon Transistor

2SA1772

■ Features

- High breakdown voltage
- Large current capacity ($I_c=1A$)

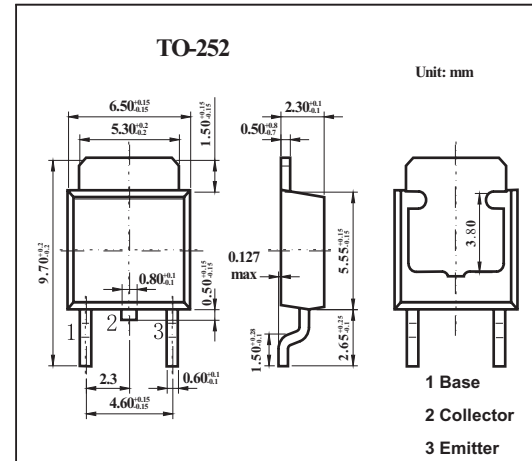

■ Absolute Maximum Ratings $T_a = 25^{\circ}C$

Parameter	Symbol	Rating	Unit
Collector to Base Voltage	V_{CBO}	-400	V
Collector to Emitter Voltage	V_{CEO}	-400	V
Emitter to Base Voltage	V_{EBO}	-5	V
Collector Current (DC)	I_c	-1	A
Collector Current (Pulse)	I_c	-2	A
Collector Dissipation $T_c=25^{\circ}C$	P_c	1	W
		15	W
Junction Temperature	T_j	150	$^{\circ}C$
Storage Temperature	T_{stg}	-55 to 150	$^{\circ}C$

2SA1772

■ Electrical Characteristics Ta = 25°C

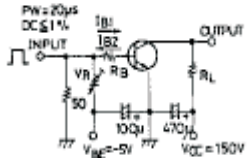
Parameter	Symbol	Testconditions	Min	Typ	Max	Unit	
Collector Cutoff Current	I _{CBO}	V _{CB} =-300V, I _E =0			-0.1	μA	
Emitter Cutoff Current	I _{EBO}	V _{EB} =-4V, I _C =0			-0.1	μA	
DC Current Gain*	h _{FE}	V _{CE} =-10V, I _C =-100mA	40		200		
Gain- Bandwidth Product	f _r	V _{CE} =-10V, I _C =-50mA		50		MHz	
C-E Saturation Voltage	V _{CE(sat)}	I _C =-200mA, I _B =-20mA			-1.0	V	
B-E Saturation Voltage	V _{BE(sat)}	I _C =-200mA, I _B =-20mA			-1.0	V	
C-B Breakdown Voltage	V _{(BR)CBO}	I _C =-10μA, I _E =0	-400			V	
C-E Breakdown Voltage	V _{(BR)CEO}	I _C =-1mA, R _{BE} =∞	-400			V	
E-B Breakdown Voltage	V _{(BR)EBO}	I _E =-10μA, I _C =0	-5			V	
Output Capacitance	C _{ob}	V _{CB} =-30V, f=1MHz		12		pF	
Turn-ON Time	t _{on}	 <p> $PW=20\mu s$ $DC 1\%$ I_{B1} I_{B2} I_C $V_{BE}=-5V$ $V_{CE}=150V$ $10I_{B1} = -10I_{B2} = I_C = 200mA$ $R_1 = 750\Omega, R_2 = 50\Omega$, at $I_C = 200mA$ (For PNP, the polarity is reversed.) Unit (Resistance : Ω, Capacitance : F) </p>		0.25		μs	
Storage Time	t _{stg}				3		
Fall Time	t _f				0.3		

■ hFE Classification

Rank	C	D	E
hFE	40 to 80	60 to 120	100 to 200