



2SA1774

PNP EPITAXIAL SILICON TRANSISTOR

GENERAL PURPOSE TRANSISTOR

FEATURES

- * Excellent h_{FE} linearity
- * Complements the UTC **2SC4617**

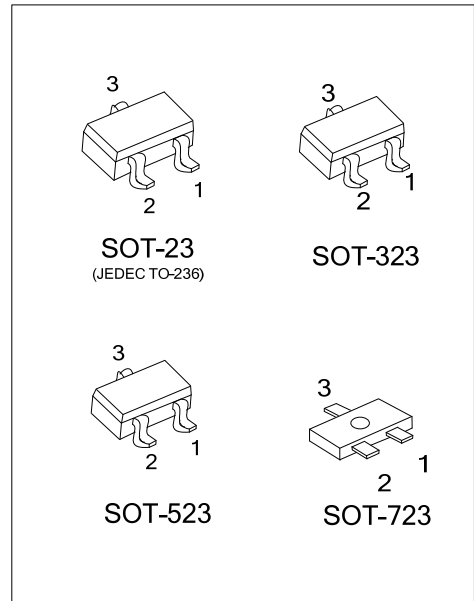

ORDERING INFORMATION

Ordering Number	Package	Pin Assignment			Packing
		1	2	3	
2SA1774G-x-AE3-R	SOT-23	E	B	C	Tape Reel
2SA1774G-x-AL3-R	SOT-323	E	B	C	Tape Reel
2SA1774G-x-AN3-R	SOT-523	E	B	C	Tape Reel
2SA1774G-x-AQ3-R	SOT-723	E	B	C	Tape Reel

Note: Pin Assignment: E: Emitter B: Base C: Collector

<p>2SA1774G-x-AE3-R</p>	<p>(1) R: Tape Reel (2) AE3: SOT-23, AL3: SOT-323, AN3: SOT-523, AQ3: SOT-723 (3) x: refer to Classification of h_{FE} (4) G: Halogen Free and Lead Free</p>
-------------------------	--

MARKING

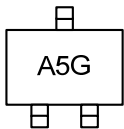

■ ABSOLUTE MAXIMUM RATING ($T_A=25^\circ\text{C}$, unless otherwise specified)

PARAMETER		SYMBOL	RATINGS	UNIT
Collector-Base Voltage		V_{CBO}	-60	V
Collector-Emitter Voltage		V_{CEO}	-50	V
Emitter-Base Voltage		V_{EBO}	-6	V
Collector Current		I_C	-0.15	A
Collector Power Dissipation	SOT-23	P_C	0.22	W
	SOT-323		0.16	
	SOT-523		0.15	
	SOT-723		0.125	
Junction Temperature		T_J	150	$^\circ\text{C}$
Storage Temperature		T_{STG}	-55 ~ +150	$^\circ\text{C}$

Note: 1. Absolute maximum ratings are those values beyond which the device could be permanently damaged. Absolute maximum ratings are stress ratings only and functional device operation is not implied.

2. The device is guaranteed to meet performance specification within $0^\circ\text{C} \sim 70^\circ\text{C}$ operating temperature range and assured by design from $-20^\circ\text{C} \sim 85^\circ\text{C}$.

■ ELECTRICAL CHARACTERISTICS ($T_A=25^\circ\text{C}$, unless otherwise specified.)

PARAMETER	SYMBOL	TEST CONDITIONS	MIN	TYP	MAX	UNIT
Collector-Base Breakdown Voltage	BV_{CBO}	$I_C = -50\mu\text{A}$	-60			V
Collector-Emitter Breakdown Voltage	BV_{CEO}	$I_C = -1\text{mA}$	-50			V
Emitter-Base Breakdown Voltage	BV_{EBO}	$I_E = -50\mu\text{A}$	-6			V
Collector Cutoff Current	I_{CBO}	$V_{CB} = -60\text{V}$			-0.1	μA
Emitter Cutoff Current	I_{EBO}	$V_{EB} = -6\text{V}$			-0.1	μA
DC Current Transfer Ratio	h_{FE}	$V_{CE} = -6\text{V}, I_C = -1\text{mA}$	120		560	
Collector-Emitter Saturation Voltage	$V_{CE(SAT)}$	$I_C = -50\text{mA}, I_B = -5\text{mA}$			-0.5	V
Transition Frequency	f_T	$V_{CE} = -12\text{V}, I_E = 2\text{mA}, f = 100\text{MHz}$		140		MHz
Output Capacitance	C_{OB}	$V_{CB} = -12\text{V}, I_E = 0\text{A}, f = 1\text{MHz}$		4.0	5.0	pF

■ CLASSIFICATION OF h_{FE1}

RANK	Q	R	S
Range	120 ~ 270	180 ~ 390	270 ~ 560

TYPICAL CHARACTERISTICS

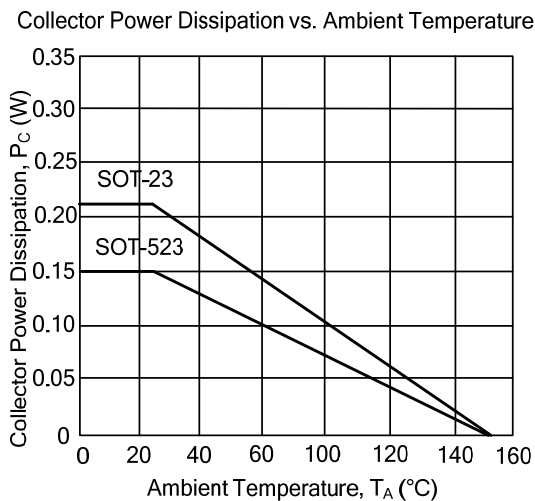
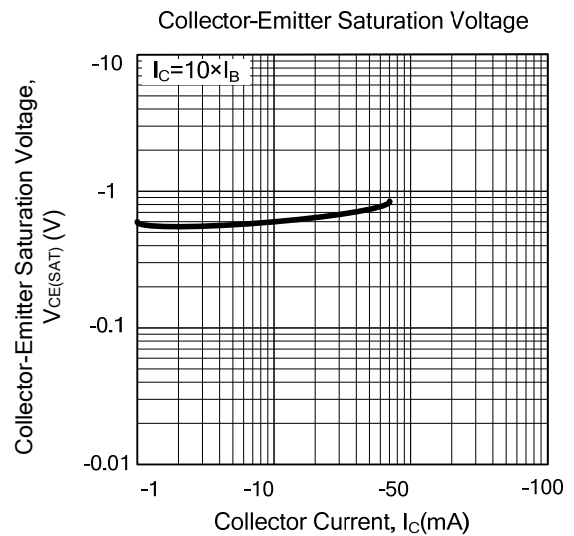
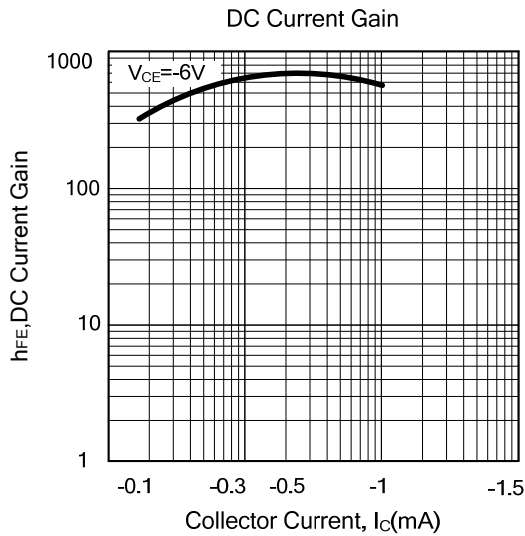

UTC assumes no responsibility for equipment failures that result from using products at values that exceed, even momentarily, rated values (such as maximum ratings, operating condition ranges, or other parameters) listed in products specifications of any and all UTC products described or contained herein. UTC products are not designed for use in life support appliances, devices or systems where malfunction of these products can be reasonably expected to result in personal injury. Reproduction in whole or in part is prohibited without the prior written consent of the copyright owner. The information presented in this document does not form part of any quotation or contract, is believed to be accurate and reliable and may be changed without notice.