

PNP Silicon Epitaxial Planar Transistor

2SA1797

FEATURES

- Low saturation voltage $V_{CE(sat)} = -0.35V(\text{Max.})$
($I_C/I_B = -1A/-0.5A$).
- Excellent DC current gain characteristics.
- Complements the 2SA1797 and 2SC4672.
- MSL 3

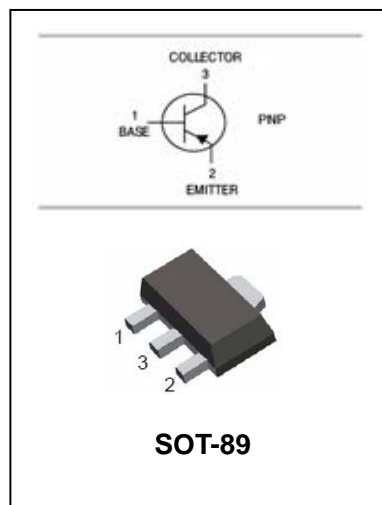

APPLICATIONS

- Low frequency transistor.

ORDERING INFORMATION

Type No.	Marking	Package Code
2SA1797	AGP/AGQ	SOT-89

MAXIMUM RATING @ $T_a = 25^\circ\text{C}$ unless otherwise specified

Symbol	Parameter	Value	Units
V_{CBO}	Collector-Base Voltage	-50	V
V_{CEO}	Collector-Emitter Voltage	-50	V
V_{EBO}	Emitter-Base Voltage	-6	V
I_C	Collector Current	DC	-2
		Pulse	-5
P_C	Collector Dissipation	500	mW
T_j, T_{stg}	Junction and Storage Temperature	-55 to +150	$^\circ\text{C}$

PNP Silicon Epitaxial Planar Transistor

2SA1797

ELECTRICAL CHARACTERISTICS @ Ta=25°C unless otherwise specified

Parameter	Symbol	Test conditions	MIN	TYP	MAX	UNIT
Collector-base breakdown voltage	$V_{(BR)CBO}$	$I_C=-50\mu A, I_E=0$	-50			V
Collector-emitter breakdown voltage	$V_{(BR)CEO}$	$I_C=-1.0mA, I_B=0$	-50			V
Emitter-base breakdown voltage	$V_{(BR)EBO}$	$I_E=-50\mu A, I_C=0$	-6			V
Collector cut-off current	I_{CBO}	$V_{CB}=-50V, I_B=0$			-0.1	μA
Emitter cut-off current	I_{EBO}	$V_{EB}=-5V, I_C=0$			-0.1	μA
DC current gain	h_{FE}	$V_{CE}=-2V, I_C=-500mA$	82		180	
			120		270	
Collector-emitter saturation voltage	$V_{CE(sat)}$	$I_C=-1A, I_B=-50mA$		-0.15	-0.35	V
Transition frequency	f_T	$V_{CE}=-2V, I_E=-500mA$ $f=100MHz$		200		MHz
Collector output capacitance	C_{ob}	$V_{CB}=-10V, I_E=0, f=1MHz$		36		pF

CLASSIFICATION OF h_{FE}

Rank	P	Q
Range	82-180	120-270
Marking	AGP	AGQ

PNP Silicon Epitaxial Planar Transistor

2SA1797

TYPICAL CHARACTERISTICS @ $T_a=25^\circ\text{C}$ unless otherwise specified

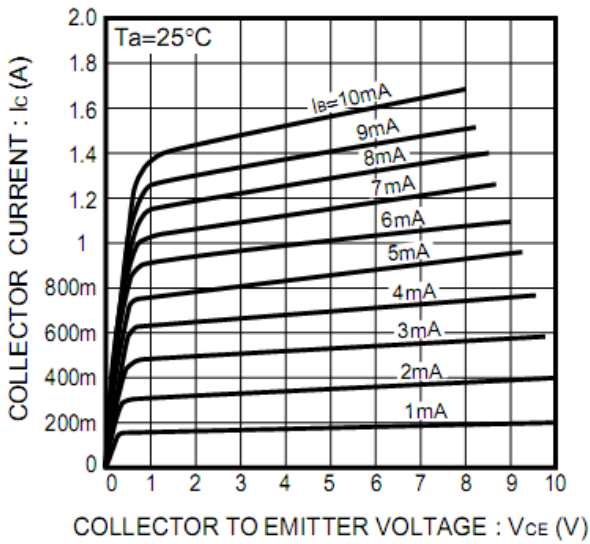

Fig.1 Grounded emitter output characteristics

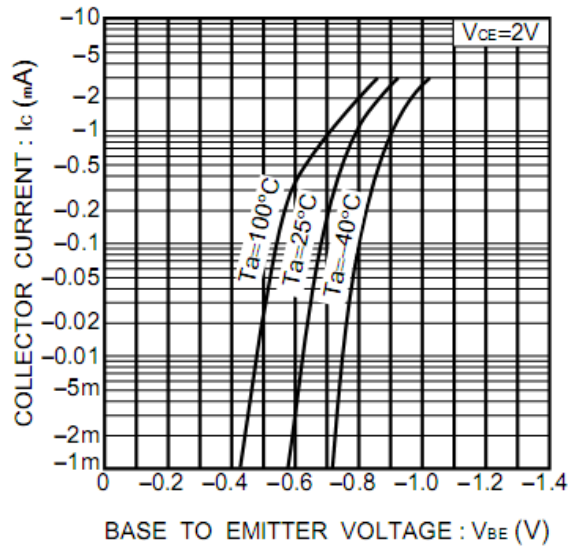

Fig.2 Grounded emitter propagation characteristics

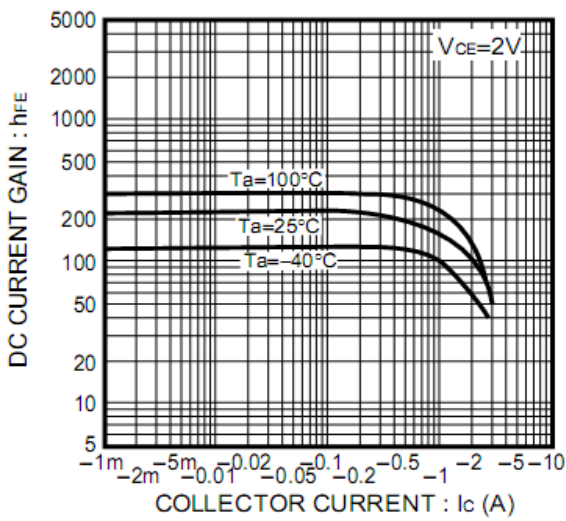

Fig.3 DC current gain vs. collector current

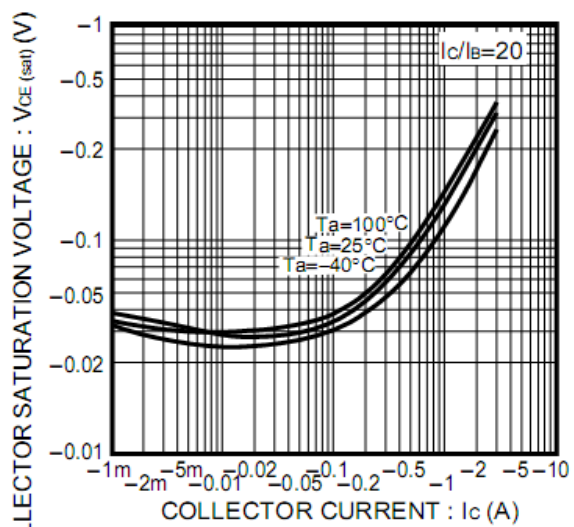

Fig.4 Collector-emitter saturation voltage vs. collector current

PNP Silicon Epitaxial Planar Transistor

2SA1797

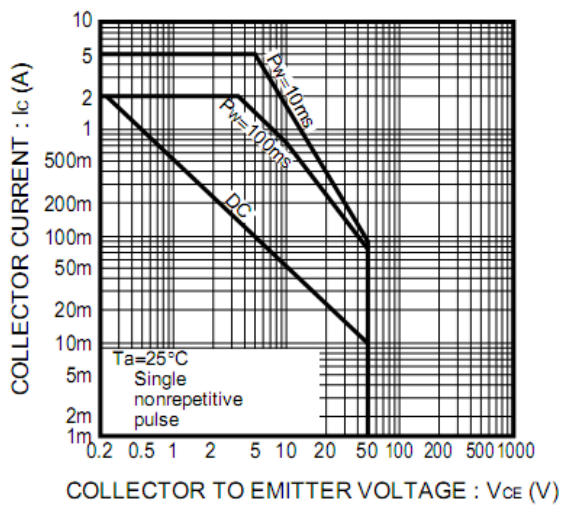

Fig.5 Safe operating area

PNP Silicon Epitaxial Planar Transistor

2SA1797

PACKAGE OUTLINE

Plastic surface mounted package

SOT-89

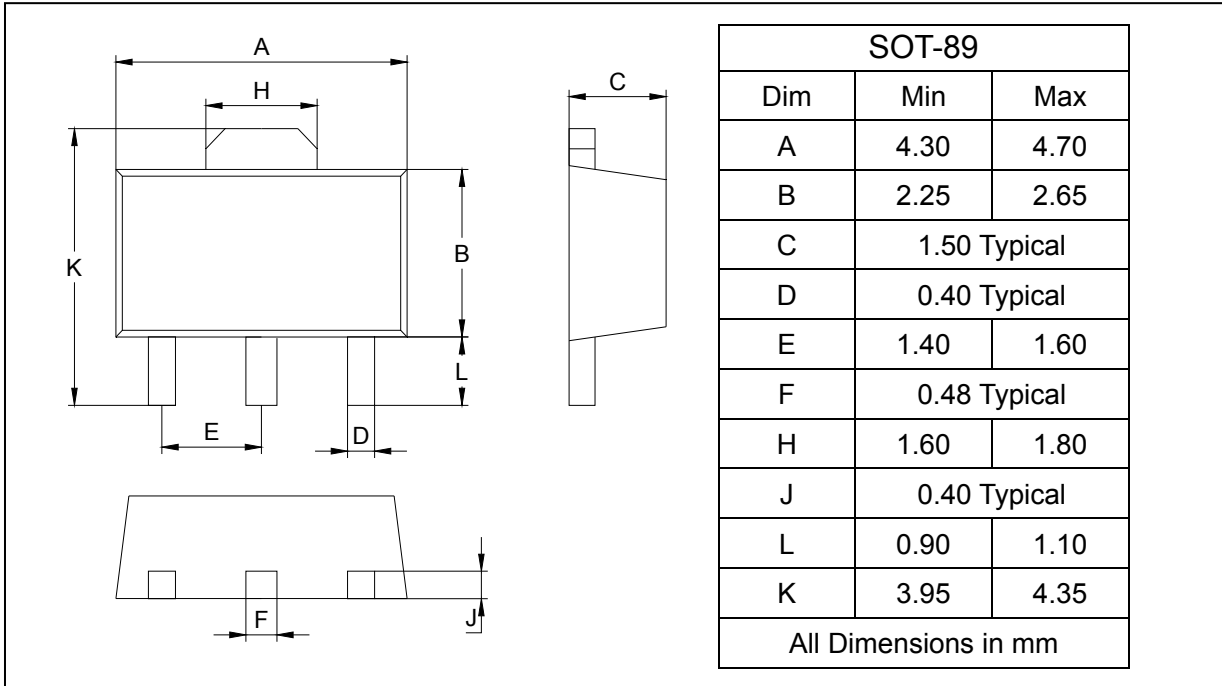

SOLDERING FOOTPRINT

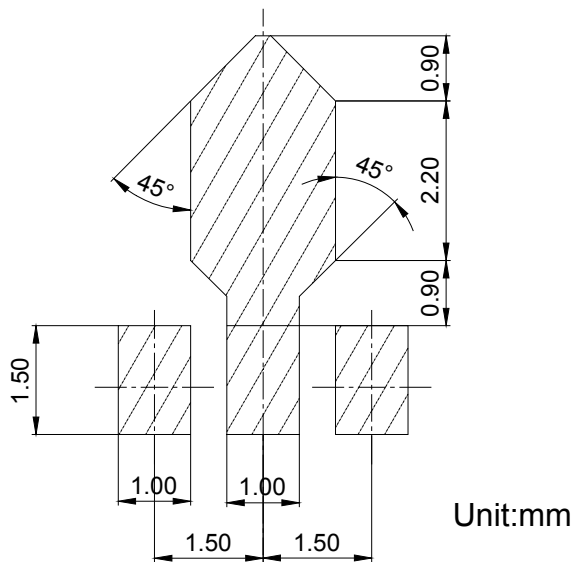

PACKAGE INFORMATION

Device	Package	Shipping
2SA1797	SOT-89	1000/Tape&Reel