



DC COMPONENTS CO., LTD.

DISCRETE SEMICONDUCTORS

2SA673

TECHNICAL SPECIFICATIONS OF PNP EPITAXIAL PLANAR TRANSISTOR

Description

Designed for low frequency amplifier applications

Pinning

- 1 = Emitter
- 2 = Collector
- 3 = Base

Absolute Maximum Ratings (T_A=25°C)

Characteristic	Symbol	Rating	Unit
Collector-Base Voltage	V _{CB0}	-35	V
Collector-Emitter Voltage	V _{CE0}	-35	V
Emitter-Base Voltage	V _{EB0}	-5	V
Collector Current	I _C	-500	mA
Total Power Dissipation	P _D	400	mW
Junction Temperature	T _J	+150	°C
Storage Temperature	T _{STG}	-55 to +150	°C

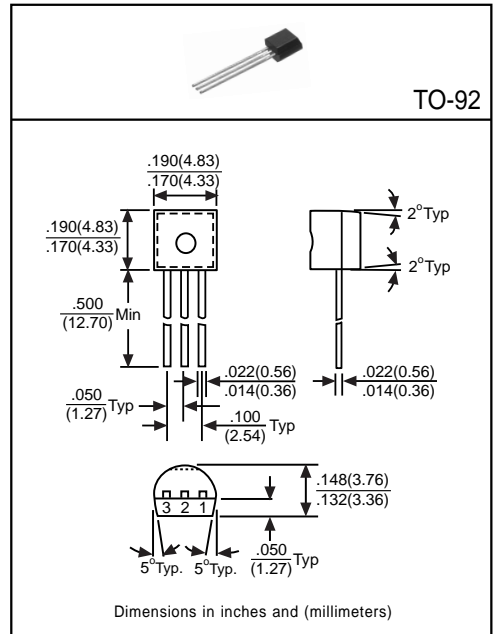

Electrical Characteristics

(Ratings at 25°C ambient temperature unless otherwise specified)

Characteristic	Symbol	Min	Typ	Max	Unit	Test Conditions
Collector-Base Breakdown Voltage	BV _{CB0}	-35	-	-	V	I _C =-100μA, I _E =0
Collector-Emitter Breakdown Voltage	BV _{CE0}	-35	-	-	V	I _C =-1mA, I _B =0
Emitter-Base Breakdown Voltage	BV _{EB0}	-5	-	-	V	I _E =-100μA, I _C =0
Collector Cutoff Current	I _{CBO}	-	-	-0.5	μA	V _{CB} =-20V, I _E =0
Emitter Cutoff Current	I _{EBO}	-	-	-0.5	μA	V _{EB} =-5V, I _C =0
Collector-Emitter Saturation Voltage ⁽¹⁾	V _{CE(sat)}	-	-0.1	-0.6	V	I _C =-150mA, I _B =-15mA
Base-Emitter Saturation Voltage ⁽¹⁾	V _{BE(sat)}	-	-	-1.2	V	I _C =-150mA, I _B =-15mA
DC Current Gain ⁽¹⁾	h _{FE1}	60	-	320	-	I _C =-10mA, V _{CE} =-3V
	h _{FE2}	35	-	-	-	I _C =-500mA, V _{CE} =-3V
Transition Frequency	f _T	-	190	-	MHz	I _C =-20mA, V _{CE} =-6V

(1) Pulse Test: Pulse Width ≤ 380μs, Duty Cycle ≤ 2%

Classification of h_{FE1}

Rank	B	C	D
Range	60~120	100~200	160~320