

TO-92 Plastic-Encapsulate Transistors

2SA719/2SA720 TRANSISTOR (PNP)

FEATURES

- For Low-Frequency Power Amplification and Driver Amplification

MAXIMUM RATINGS (T_a=25°C unless otherwise noted)

Symbol	Parameter	Value	Unit
V _{CBO}	Collector-Base Voltage 2SA719	-30	V
	2SA720	-60	
V _{CEO}	Collector-Emitter Voltage 2SA719	-25	V
	2SA720	-50	
V _{EBO}	Emitter-Base Voltage	-5	V
I _C	Collector Current -Continuous	-500	mA
P _C	Collector Power Dissipation	625	mW
T _J	Junction Temperature	150	°C
T _{stg}	Storage Temperature	-55-150	°C

TO-92

1. EMITTER
2. COLLECTOR
3. BASE

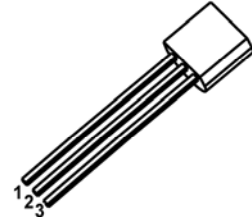

ELECTRICAL CHARACTERISTICS (T_a=25°C unless otherwise specified)

Parameter	Symbol	Test conditions	Min	Typ	Max	Unit
Collector-base breakdown voltage	V _{(BR)CBO}	I _C = -10uA, I _E =0	-30			V
2SA719			-60			
Collector-emitter breakdown voltage	V _{(BR)CEO}	I _C = -10mA, I _B =0	-25			V
2SA719			-50			
Emitter-base breakdown voltage	V _{(BR)EBO}	I _E = -10uA, I _C =0 -5				V
Collector cut-off current	I _{CBO}	V _{CB} = -20V, I _E =0			-0.1	uA
Emitter cut-off current	I _{EBO}	V _{EB} = -4V, I _C =0			-0.1	uA
DC current gain	h _{FE(1)}	V _{CE} =-10V, I _C = -150mA	85		340	
	h _{FE(2)}	V _{CE} =-10V, I _C = -500mA	40			
Collector-emitter saturation voltage	V _{CE(sat)}	I _C =-300mA, I _B = -30mA			-0.6	V
Base-emitter saturation voltage	V _{BE(sat)}	I _C = -300mA, I _B =-30mA			-1.5	V
Transition frequency	f _T	V _{CE} = -10V, I _C = -50mA f = 200MHz	200			MHz
Collector Output Capacitance	Cob V	V _{CB} =-10V, I _E =0, f=1MHz			15	pF

CLASSIFICATION h_{FE(1)}

Rank	Q	R	S
Range	85-170	120-240	170-340

Typical Characteristics

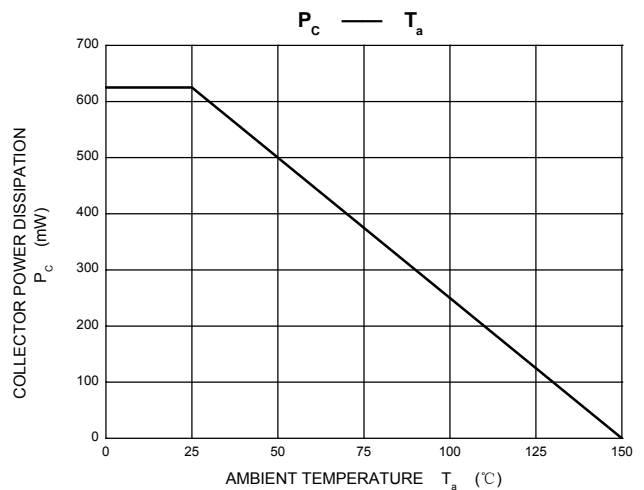
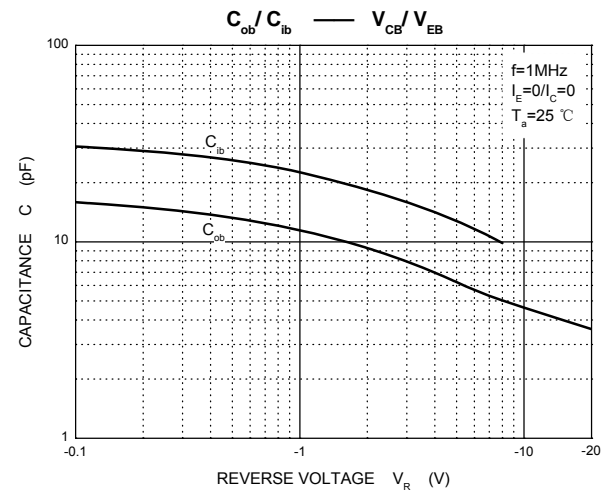
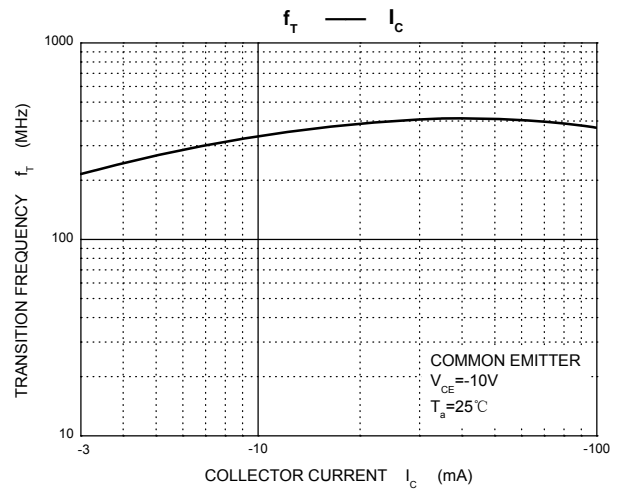
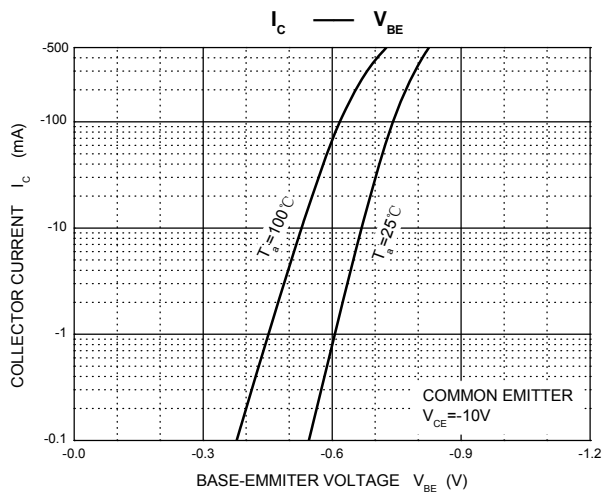
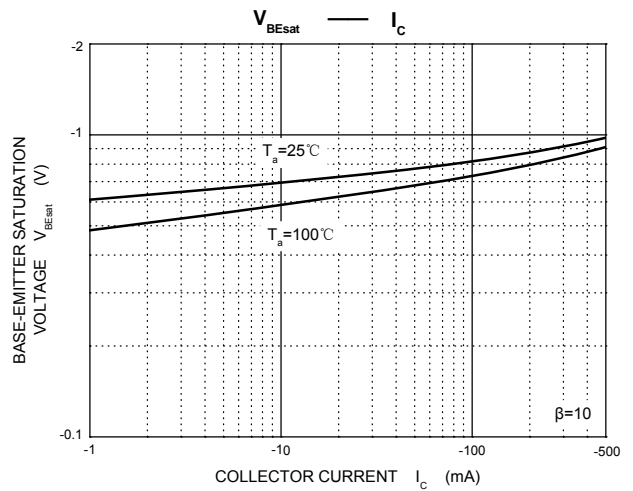
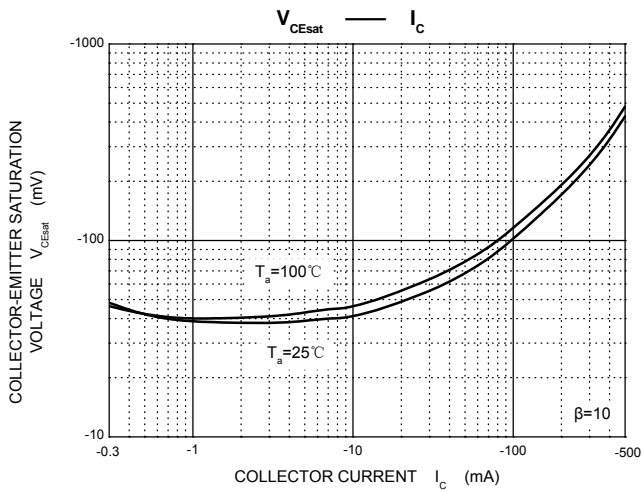
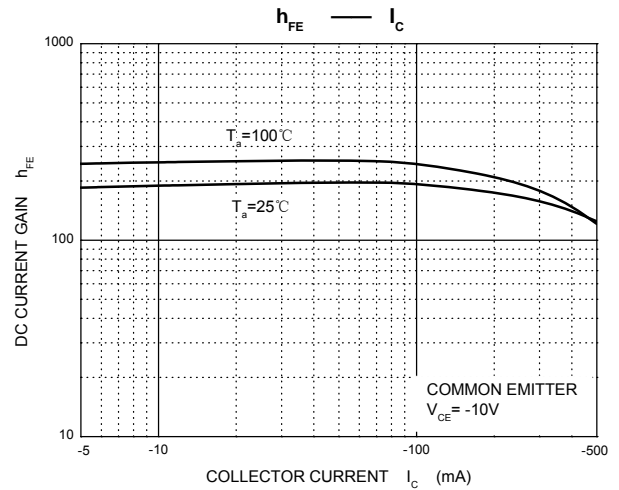
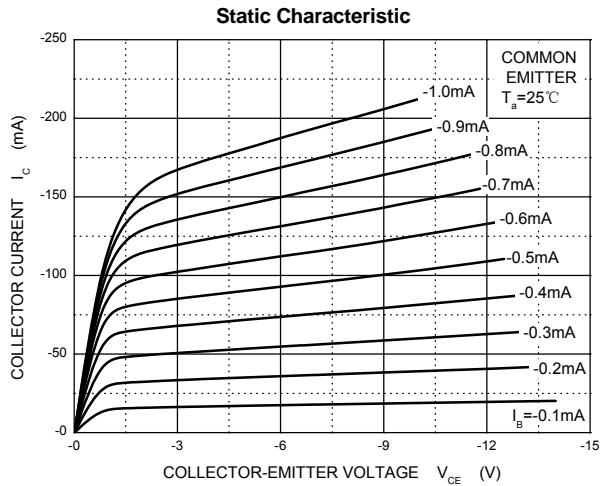

TO-92 Package Outline Dimensions



Symbol	Dimensions In Millimeters		Dimensions In Inches	
	Min	Max	Min	Max
A	3.300	3.700	0.130	0.146
A1	1.100	1.400	0.043	0.055
b	0.380	0.550	0.015	0.022
c	0.360	0.510	0.014	0.020
D	4.300	4.700	0.169	0.185
D1	3.430		0.135	
E	4.300	4.700	0.169	0.185
e	1.270 TYP		0.050 TYP	
e1	2.440	2.640	0.096	0.104
L	14.100	14.500	0.555	0.571
Φ		1.600		0.063
h	0.000	0.380	0.000	0.015

TO-92 Suggested Pad Layout



Note:

1. Controlling dimension: in millimeters.
2. General tolerance: $\pm 0.05\text{mm}$.
3. The pad layout is for reference purposes only.

NOTICE

JCET reserve the right to make modifications, enhancements, improvements, corrections or other changes without further notice to any product herein. JCET does not assume any liability arising out of the application or use of any product described herein.

TO-92 PACKAGE TAPEING DIMENSION

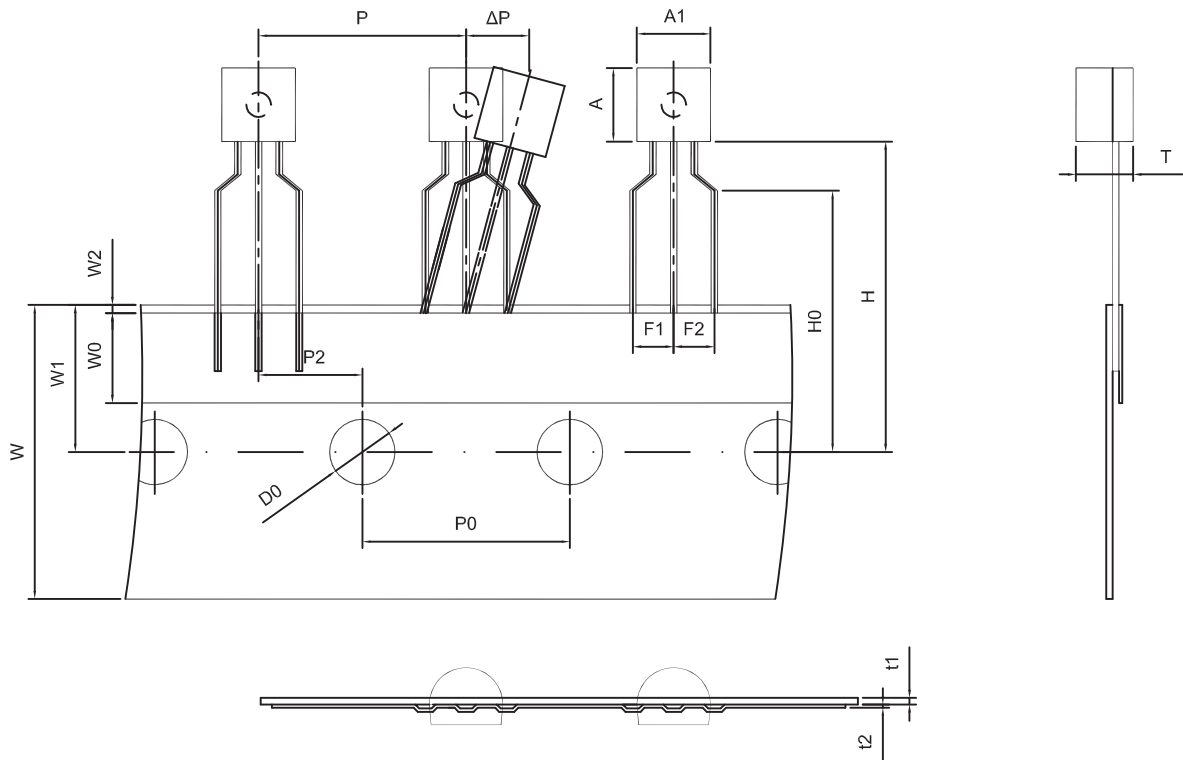

Dimiensions are in millimeter								
A1	A	T	P	P0	P2	F1	F2	W
4.5	4.5	3.5	12.7	12.7	6.35	2.5	2.5	18.0
W0	W1	W2	H	H0	D0	t1	t2	ΔP
6.0	9.0	1.0 MAX.	19.0	16.0	4.0	0.4	0.2	0

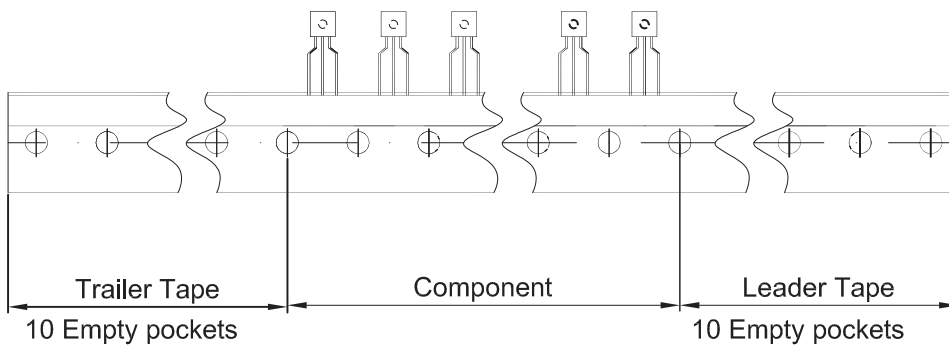

Package	Box	Box Size(mm)	Carton	Carton Size(mm)
TO-92	2000 pcs	333×162×43	20,000 pcs	350×340×250