

## Low $V_{CE(sat)}$ Transistor(-20V,-3A)

## 2SB1424

### FEATURES

- Low  $V_{CE(SAT)}=-0.2V$ (Typ.)  
( $I_C/I_B=-2A/-0.1mA$ ).
- Excellent DC current gain characteristics.
- Complementary the 2SD2150.

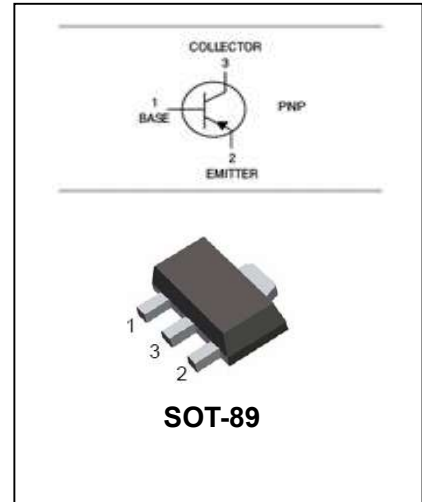

### APPLICATIONS

- This device is designed as a general purpose amplifier and switching.

### ORDERING INFORMATION

Type No.	Marking	Package Code
2SB1424	AEQ/AER	SOT-89

### MAXIMUM RATING @ $T_a=25^{\circ}C$ unless otherwise specified

Symbol	Parameter	Value	Unit
$V_{CBO}$	Collector-Base Voltage	-20	V
$V_{CEO}$	Collector-Emitter Voltage	-20	V
$V_{EBO}$	Emitter-Base Voltage	-6	V
$I_C$	Collector Current -DC -Pulse	-3 -5	A
$P_C$	Collector power Dissipation	0.5	W
$T_j, T_{stg}$	Junction and Storage Temperature	-55 to +150	$^{\circ}C$

## Low $V_{CE(sat)}$ Transistor(-20V,-3A)

## 2SB1424

ELECTRICAL CHARACTERISTICS @  $T_a=25^\circ\text{C}$  unless otherwise specified

Parameter	Symbol	Test conditions	MIN	TYP	MAX	UNIT
Collector-base breakdown voltage	$V_{(BR)CBO}$	$I_C=-50\mu\text{A}$ $I_E=0$	-20			V
Collector-emitter breakdown voltage	$V_{(BR)CEO}$	$I_C=-1\text{mA}$ $I_B=0$	-20			V
Emitter-base breakdown voltage	$V_{(BR)EBO}$	$I_E=-50\mu\text{A}$ $I_C=0$	-6			V
Collector cut-off current	$I_{CBO}$	$V_{CB}=-20\text{V}$ $I_E=0$			-0.1	$\mu\text{A}$
Emitter cut-off current	$I_{EBO}$	$V_{EB}=-5\text{V}$ , $I_C=0$			-0.1	$\mu\text{A}$
DC current gain	$h_{FE}$	$V_{CE}=-2\text{V}$ $I_C=-0.1\text{A}$	120		390	
Collector-emitter saturation voltage	$V_{CE(sat)}$	$I_C=-2\text{A}$ $I_B=-0.1\text{A}$			-0.5	V
Transition frequency	$f_T$	$V_{CE}=-2\text{V}$ , $I_C=-0.5\text{A}$ , $f=100\text{MHz}$		240		MHz
Output Capacitance	$C_{obo}$	$V_{CB}=-10\text{V}$ $f=1\text{MHz}$ $I_E=0$	-	35		pF

### CLASSIFICATION $h_{FE}$

Rank	Q	R
Range	120-270	180-390
Marking	AEQ	AER

TYPICAL CHARACTERISTICS @  $T_a=25^\circ\text{C}$  unless otherwise specified

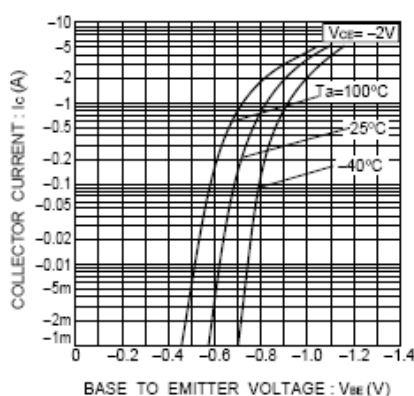

Fig. 1 Grounded emitter propagation characteristics

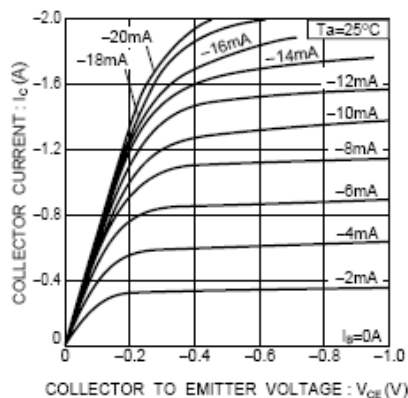

Fig. 2 Grounded emitter output characteristics ( I )

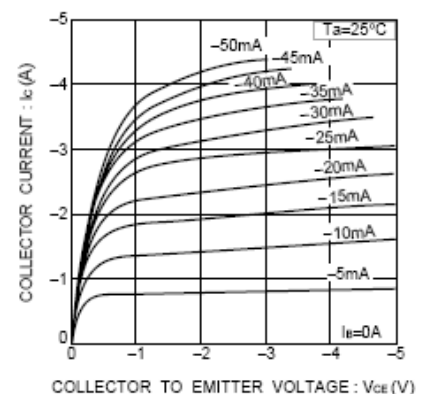

Fig. 3 Grounded emitter output characteristics ( II )

**Low  $V_{CE(sat)}$  Transistor(-20V,-3A)**

**2SB1424**

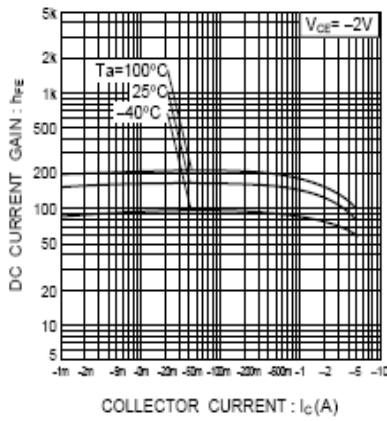

Fig.4 DC current gain vs. collector current

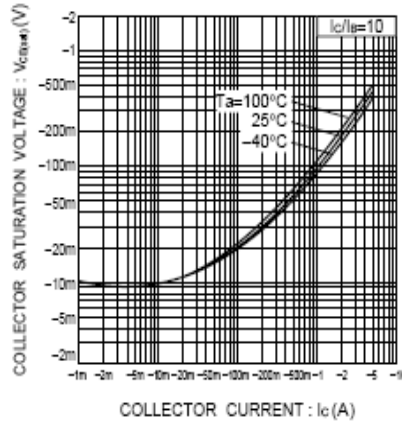

Fig.5 Collector-emitter saturation voltage vs. collector current ( I )

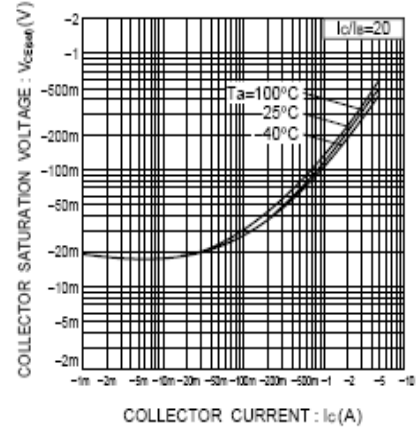

Fig.6 Collector-emitter saturation voltage vs. collector current ( II )

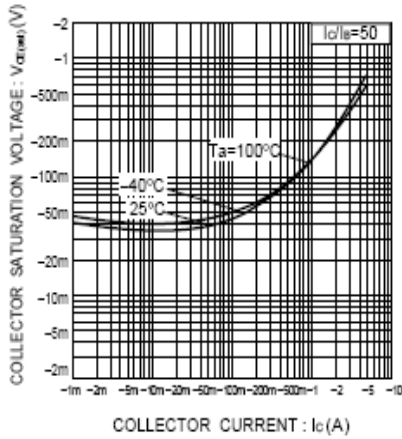

Fig.7 Collector-emitter saturation voltage vs. collector current ( III )

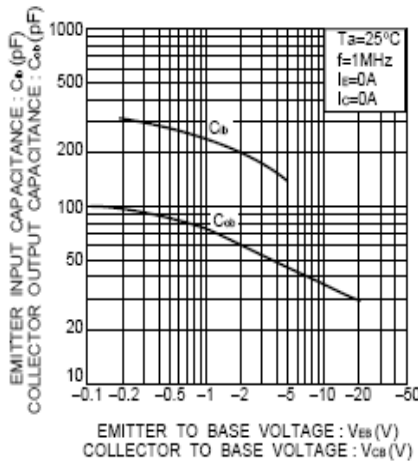

Fig.8 Gain bandwidth product vs. emitter current  
Collector output capacitance vs. collector-base voltage

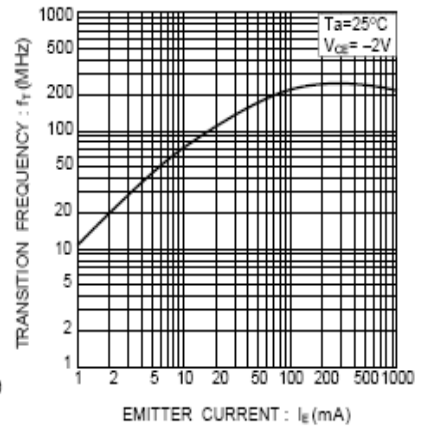

Fig.9 Emitter input capacitance vs. emitter base voltage

## Low $V_{CE(sat)}$ Transistor(-20V,-3A)

## 2SB1424

### PACKAGE OUTLINE

Plastic surface mounted package

SOT-89

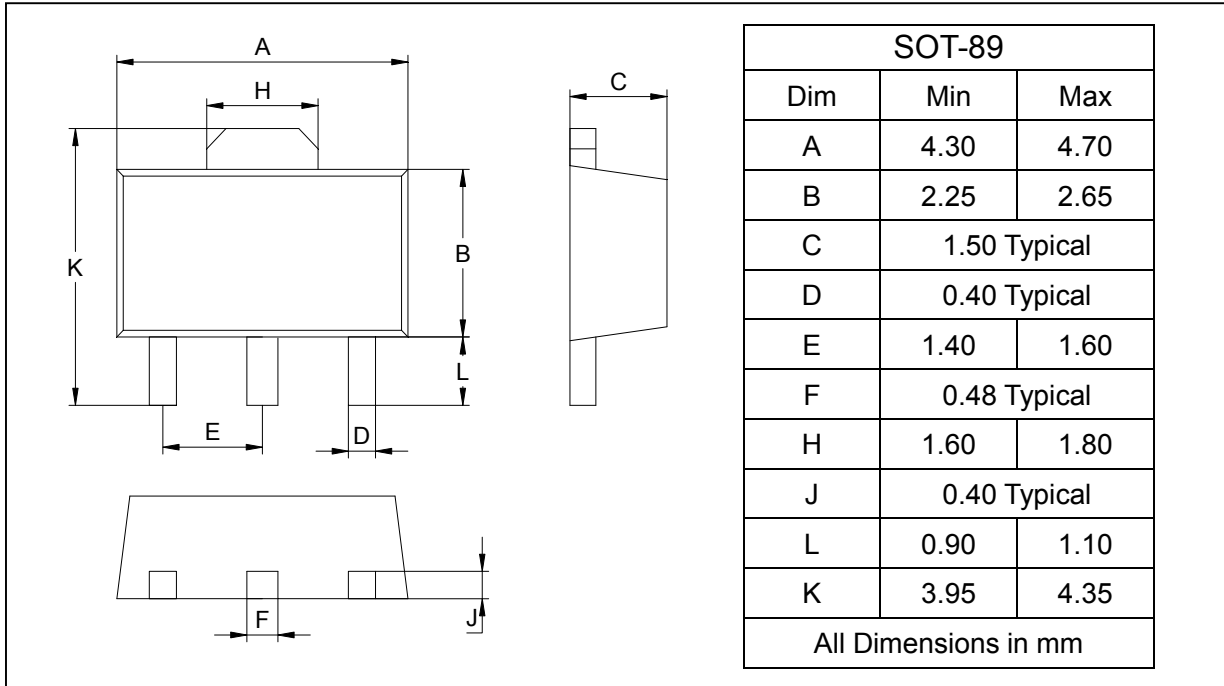

### SOLDERING FOOTPRINT

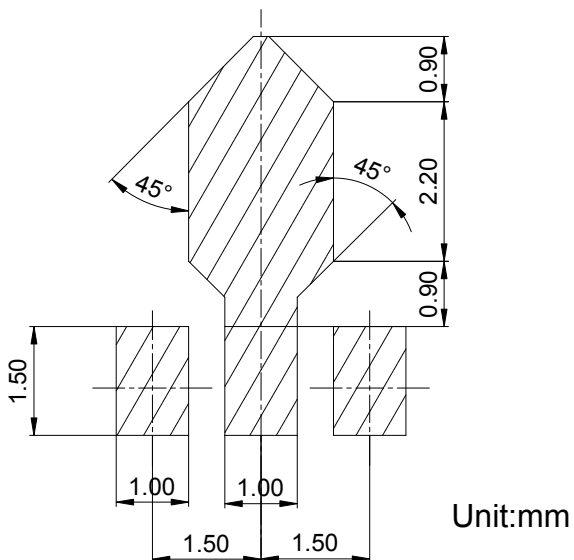

### PACKAGE INFORMATION

Device	Package	Shipping
2SB1424	SOT-89	1000/Tape&Reel