

**Silicon PNP Power Transistors**

**2SB509**

**DESCRIPTION**

- With TO-66 package
- Complement to type 2SD315

**APPLICATIONS**

- For use in audio frequency power amplifier application

**PINNING(see Fig.2)**

PIN	DESCRIPTION
1	Base
2	Emitter
3	Collector

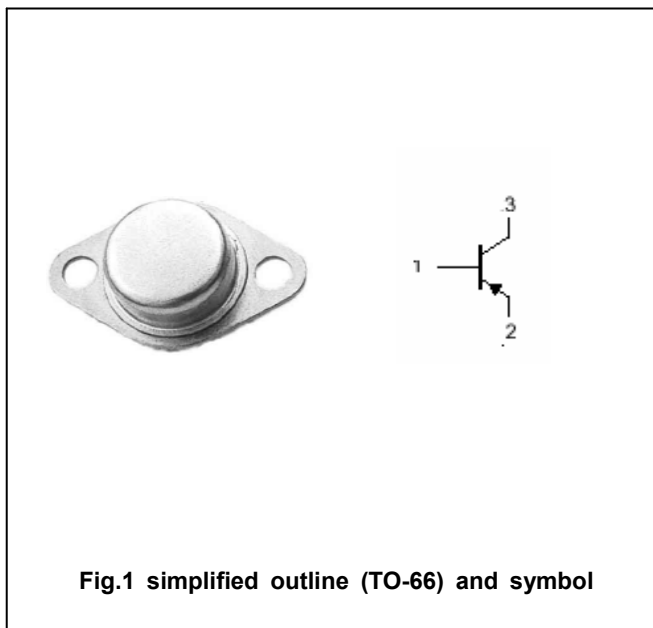

Fig.1 simplified outline (TO-66) and symbol

**Absolute maximum ratings(Ta=□)**

SYMBOL	PARAMETER	CONDITIONS	VALUE	UNIT
V <sub>CBO</sub>	Collector-base voltage	Open emitter	-60	V
V <sub>CEO</sub>	Collector-emitter voltage	Open base	-60	V
V <sub>EBO</sub>	Emitter-base voltage	Open collector	-5	V
I <sub>C</sub>	Collector current		-4	A
I <sub>CM</sub>	Collector current-peak		-10	A
P <sub>C</sub>	Collector power dissipation	T <sub>C</sub> =25□	35	W
T <sub>j</sub>	Junction temperature		150	□
T <sub>stg</sub>	Storage temperature		-40~150	□

## Silicon PNP Power Transistors

## 2SB509

## CHARACTERISTICS

T<sub>j</sub>=25°C unless otherwise specified

SYMBOL	PARAMETER	CONDITIONS	MIN	TYP.	MAX	UNIT
V <sub>(BR)CEO</sub>	Collector-emitter breakdown voltage	I <sub>C</sub> =-10mA ; I <sub>B</sub> =0	-60			V
V <sub>CEsat</sub>	Collector-emitter saturation voltage	I <sub>C</sub> =-2A; I <sub>B</sub> =-0.2A			-1.0	V
V <sub>BE</sub>	Base-emitter on voltage	I <sub>C</sub> =-1A ; V <sub>CE</sub> =-2V			-1.5	V
I <sub>CB0</sub>	Collector cut-off current	V <sub>CB</sub> =-20V; I <sub>E</sub> =0			-0.1	mA
I <sub>EB0</sub>	Emitter cut-off current	V <sub>EB</sub> =-4V; I <sub>C</sub> =0			-1.0	mA
h <sub>FE-1</sub>	DC current gain	I <sub>C</sub> =-1A ; V <sub>CE</sub> =-2V	40		320	
h <sub>FE-2</sub>	DC current gain	I <sub>C</sub> =-0.1A ; V <sub>CE</sub> =-2V	40			
f <sub>T</sub>	Transition frequency	I <sub>C</sub> =-0.5A ; V <sub>CE</sub> =-5V		8		MHz

◆ h<sub>FE-1</sub> Classifications

C	D	E	F
40-80	60-120	100-200	160-320

Silicon PNP Power Transistors

2SB509

PACKAGE OUTLINE

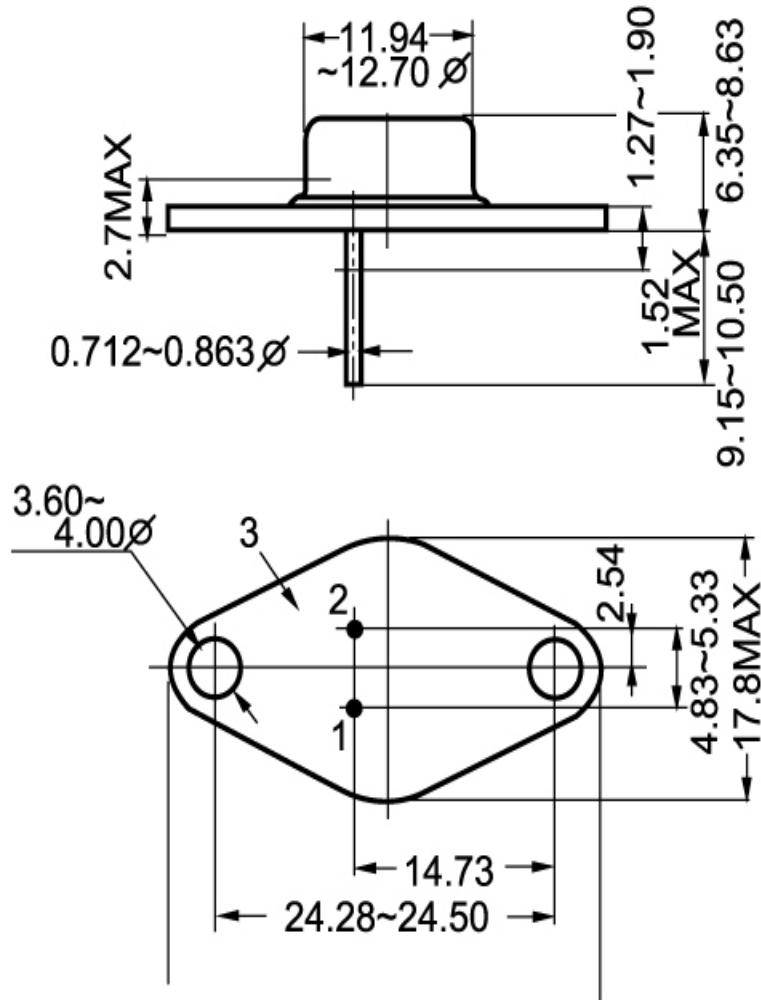

Fig.2 outline dimensions