



2SB562

PN EPITAXIAL SILICON TRANSISTOR

LOW FREQUENCY POWER AMPLIFIER

■ FEATURES

- * Low frequency power amplifier
- * Complement to 2SD468

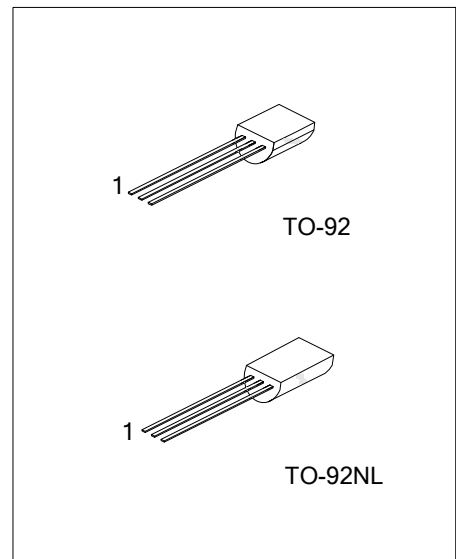

■ ORDERING INFORMATION

Order Number		Package	Pin Assignment			Packing
Lead Free	Halogen Free		1	2	3	
2SB562L-x-T92-B	2SB562G-x-T92-B	TO-92	E	C	B	Tape Box
2SB562L-x-T92-K	2SB562G-x-T92-K	TO-92	E	C	B	Bulk
2SB562L-x-T9N-B	2SB562G-x-T9N-B	TO-92NL	E	C	B	Tape Box
2SB562L-x-T9N-K	2SB562G-x-T9N-K	TO-92NL	E	C	B	Bulk

Note: Pin Assignment: E: Emitter C: Collector B: Base

<p>2SB562L-x-T92-R</p> <p>(1) Packing Type (2) Package Type (3) Rank (4) Green Package</p>	<p>(1) B: Tape Box, K: Bulk (2) T92: TO-92, T9N: TO-92NL (3) x: refer to Classification of h_{FE} (4) L: Lead Free, G: Halogen Free and Lead Free</p>
--	--

■ MARKING

TO-92	TO-92NL
<p>UTC B562 □ □ □ □ □ 1</p> <p>→ L: Lead Free → P: Halogen Free → Data Code</p>	<p>UTC 2SB562 □ □ □ □ □</p> <p>→ L: Lead Free → G: Halogen Free → Data Code</p>

■ ABSOLUTE MAXIMUM RATING ($T_A=25^\circ\text{C}$, unless otherwise specified)

PARAMETER	SYMBOL	RATINGS	UNIT
Collector-Base Voltage	V_{CBO}	-25	V
Collector-Emitter Voltage	V_{CEO}	-20	V
Emitter-Base Voltage	V_{EBO}	-5	V
Collector Current	I_C	-1	A
Collector Peak Current	I_C (peak)	-1.5	A
Collector Power Dissipation	P_C	0.9	W
Junction Temperature	T_J	150	$^\circ\text{C}$
Storage Temperature	T_{STG}	-55 ~ +150	$^\circ\text{C}$

Note: Absolute maximum ratings are those values beyond which the device could be permanently damaged.

Absolute maximum ratings are stress ratings only and functional device operation is not implied.

■ ELECTRICAL CHARACTERISTICS ($T_A=25^\circ\text{C}$, unless otherwise specified)

PARAMETER	SYMBOL	TEST CONDITIONS	MIN	TYP	MAX	UNIT
Collector to Base Breakdown Voltage	$V_{(BR)CBO}$	$I_C=-10\mu\text{A}$, $I_E=0$	-25			V
Collector to Emitter Breakdown Voltage	$V_{(BR)CEO}$	$I_C=-1\text{mA}$, $R_{BE}=\infty$	-20			V
Emitter to Base Breakdown Voltage	$V_{(BR)EBO}$	$I_E=-10\mu\text{A}$, $I_C=0$	-5			V
Collector Cut-Off Current	I_{CBO}	$V_{CB}=-20\text{V}$, $I_E=0$			-1	μA
DC Current Transfer Ratio	h_{FE}	$V_{CE}=-2\text{V}$, $I_C=-0.5\text{A}$ (note)	85		240	
Collector to Emitter Saturation Voltage	$V_{CE(sat)}$	$I_C=-0.8\text{A}$, $I_B=-0.08\text{A}$ (note)		-0.2	-0.5	V
Base to Emitter Voltage	V_{BE}	$V_{CE}=-2\text{V}$, $I_C=-0.5\text{A}$ (note)		-0.8	-1.0	V
Gain Bandwidth Product	f_T	$V_{CE}=-2\text{V}$, $I_C=-0.5\text{A}$ (note)		350		MHz
Collector Output Capacitance	C_{ob}	$V_{CB}=-10\text{V}$, $I_E=0$, $f=1\text{MHz}$		38		pF

Note 1: Pulse test

■ CLASSIFICATION OF h_{FE}

RANK	B	C
RANGE	85 - 170	120 - 240

■ TYPICAL CHARACTERISTICS

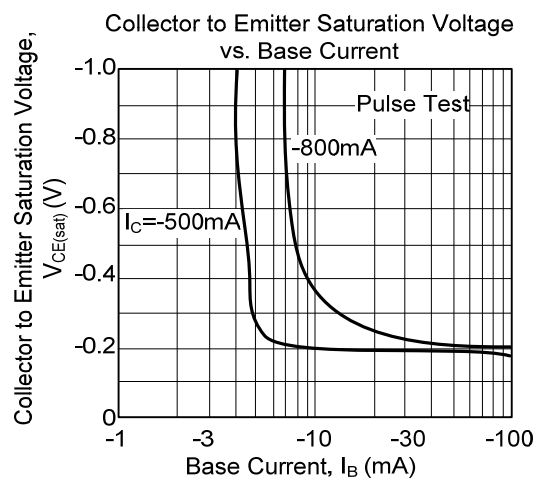
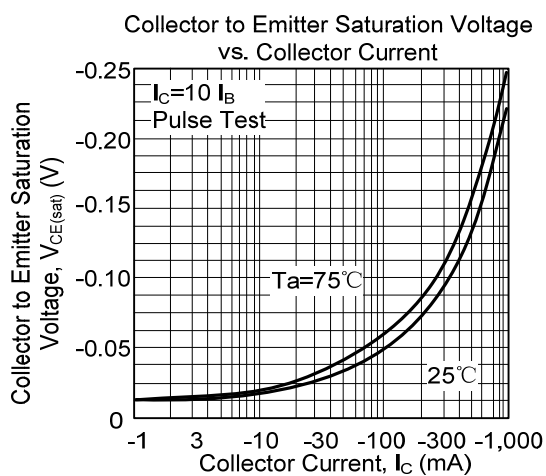
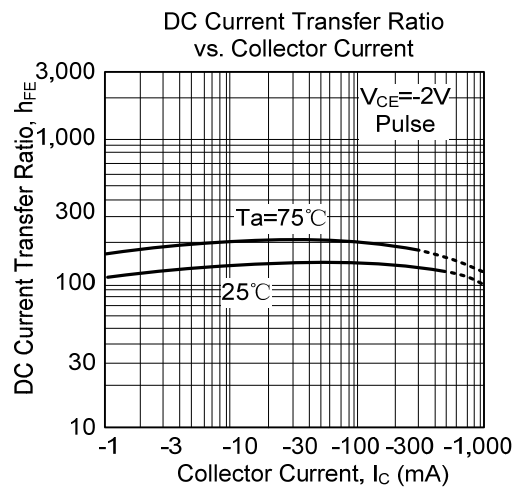
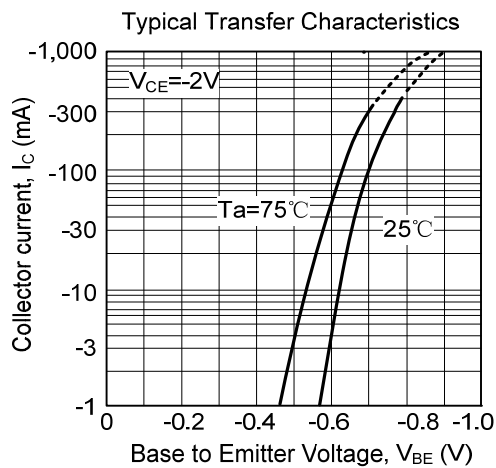
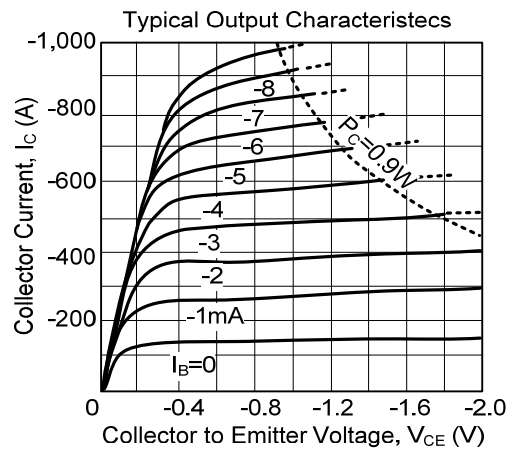
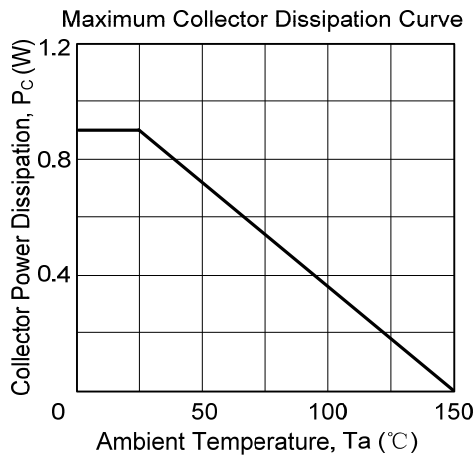

■ TYPICAL CHARACTERISTICS

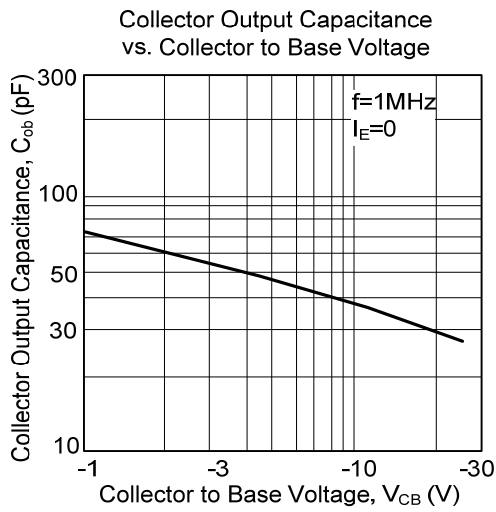

UTC assumes no responsibility for equipment failures that result from using products at values that exceed, even momentarily, rated values (such as maximum ratings, operating condition ranges, or other parameters) listed in products specifications of any and all UTC products described or contained herein. UTC products are not designed for use in life support appliances, devices or systems where malfunction of these products can be reasonably expected to result in personal injury. Reproduction in whole or in part is prohibited without the prior written consent of the copyright owner. The information presented in this document does not form part of any quotation or contract, is believed to be accurate and reliable and may be changed without notice.