

2SC108A 2SC109A

HIGH FREQUENCY AMPLIFIER APPLICATIONS.
HIGH SPEED SWITCHING APPLICATIONS.

FEATURES:

- High Switching Speed: $t_{stg}=60\text{nS}$ (Typ.)
- High Transition Frequency: $f_T = 150\text{MHz}$ (Typ.)
- High Breakdown Voltage
: $V_{CBO}=90\text{V}$ (2SC108A)
- Low Collector Saturation Voltage
: $V_{CE(sat)}=0.4\text{V(Max.)}$ at $I_C=200\text{mA}$, $I_B=20\text{mA}$

MAXIMUM RATINGS (Ta=25°C)

CHARACTERISTIC		SYMBOL	RATING	UNIT
Collector-Base Voltage	2SC108A	V_{CBO}	90	v
	2SC109A		70	
Collector-Emitter Voltage	2SC108A	V_{CEO}	70	v
	2SC109A		50	
Emitter-Base Voltage		V_{EBO}	5	v
Collector Current		I_C	800	mA
Base Current		I_B	100	mA
Collector Power Dissipation		PC	800	mW
Junction Temperature		T_j	175	°C
Storage Temperature Range		T_{stg}	-65~175	°C

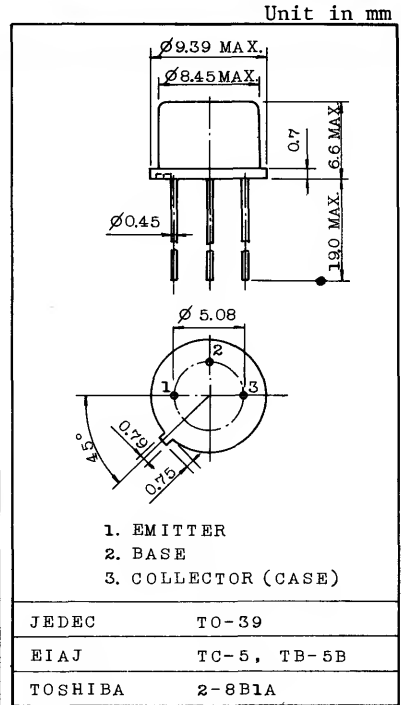

Weight : 1.14g

ELECTRICAL CHARACTERISTICS (Ta=25°C)

CHARACTERISTIC		SYMBOL	TEST CONDITION	MIN.	TYP.	MAX.	UNIT
Collector Cut-off Current	2SC108A	I_{CBO}	$V_{CB}=80\text{V}$, $I_E=0$	-	-	0.5	μA
	2SC109A		$V_{CB}=60\text{V}$, $I_E=0$				
Emitter Cut-off Current		I_{EBO}	$V_{EB}=5\text{V}$, $I_C=0$	-	-	1.0	μA
DC Current Gain		h_{FE} (Note)	$V_{CE}=2\text{V}$, $I_C=200\text{mA}$	40	-	240	
Saturation Voltage	Collector-Emitter	$V_{CE(sat)}$	$I_C=200\text{mA}$, $I_B=20\text{mA}$	-	0.2	0.4	v
	Base-Emitter	$V_{BE(sat)}$	$I_C=200\text{mA}$, $I_B=20\text{mA}$	-	0.8	1.0	
Transition Frequency		f_T	$V_{CE}=10\text{V}$, $I_C=10\text{mA}$	100	150	-	MHz
Collector Output Capacitance		C_{ob}	$V_{CB}=10\text{V}$, $I_E=0$, $f=1\text{MHz}$	-	9	15	pF
Switching Time	Turn-on Time	t_{on}		-	30	70	ns
	Storage Time	t_{stg}		-	60	80	
	Fall Time	t_f		-	20	40	

Note : h_{FE} Classification R : 40 ~ 80, O : 70 ~ 140, Y : 120 ~ 240