

Silicon NPN Power Transistors

2SC1002

DESCRIPTION

- With TO-66 package
- High voltage
- High transition frequency

APPLICATIONS

- For color TV video output applications

PINNING (See Fig.2)

PIN	DESCRIPTION
1	Base
2	Emitter
3	Collector

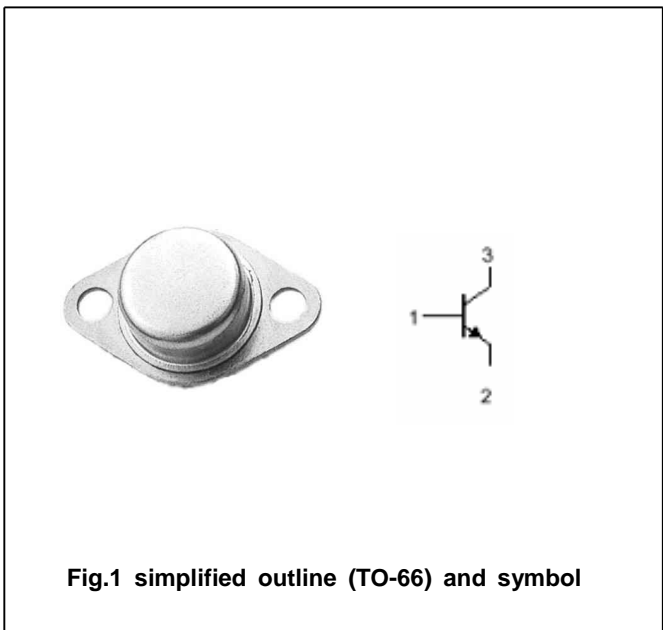

Absolute maximum ratings(Ta=25?)

SYMBOL	PARAMETER	CONDITIONS	VALUE	UNIT
V _{CBO}	Collector-base voltage	Open emitter	300	V
V _{CEO}	Collector-emitter voltage	Open base	300	V
V _{EBO}	Emitter-base voltage	Open collector	5	V
I _C	Collector current		50	mA
P _T	Total power dissipation	T _C =25?	11	W
T _j	Junction temperature		150	?
T _{stg}	Storage temperature		-55~150	?

Silicon NPN Power Transistors

2SC1002

CHARACTERISTICS

T_j=25° unless otherwise specified

SYMBOL	PARAMETER	CONDITIONS	MIN	TYP.	MAX	UNIT
V _{CEO(SUS)}	Collector-emitter sustaining voltage	I _C =0.1mA ; I _B =0	300			V
V _{(BR)EBO}	Emitter-base breakdown voltage	I _E =1μA; I _C =0	5			V
V _{CEsat}	Collector-emitter saturation voltage	I _C =20mA; I _B =2mA			1.0	V
V _{BEsat}	Base-emitter saturation voltage	I _C =20mA; I _B =2mA			1.5	V
I _{CEO}	Collector cut-off current	V _{CE} =200V; I _B =0			1	μA
I _{EBO}	Emitter cut-off current	V _{EB} =5V; I _C =0			1	μA
h _{FE}	DC current gain	I _C =10mA ; V _{CE} =10V	40		200	
f _T	Transition frequency	I _C =10mA ; V _{CE} =20V	60			MHz

PACKAGE OUTLINE

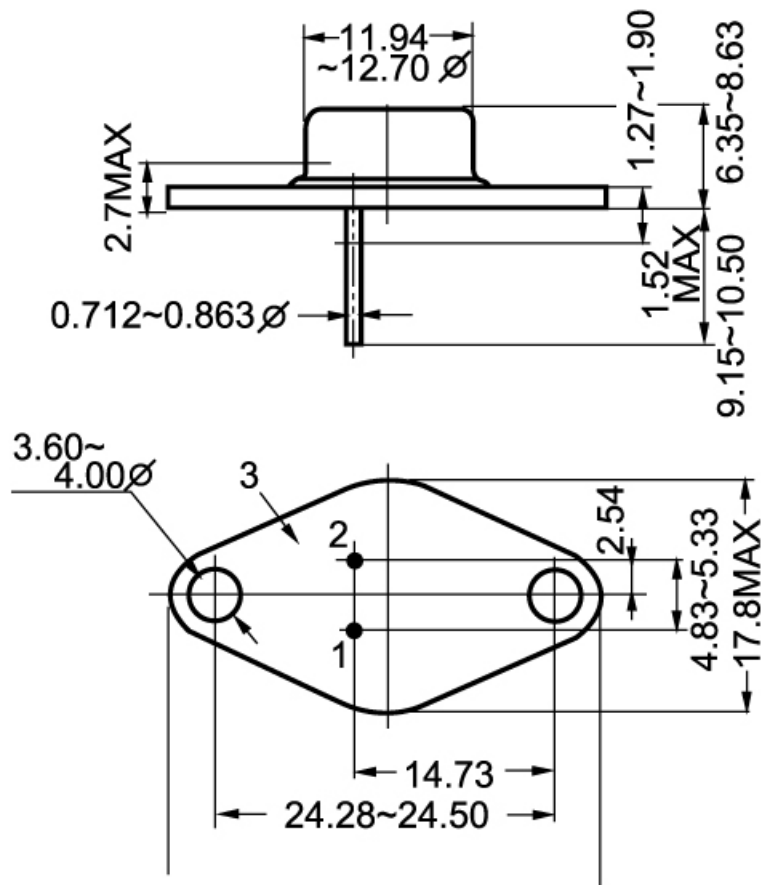

Fig.2 Outline dimensions