



**NPN SILICON HIGH
FREQUENCY TRANSISTOR**

**NE021
SERIES**

T-31-19

FEATURES

- **HIGH INSERTION GAIN:** 18.5 dB at 500 MHz
- **LOW NOISE FIGURE:** 1.5 dB at 500 MHz
- **HIGH POWER GAIN:** 12 dB at 2 GHz
- **LARGE DYNAMIC RANGE:** 19 dBm at 1 dB 2 GHz Gain Compression

DESCRIPTION AND APPLICATIONS

The NE021 series of NPN silicon transistors provides economical solutions to wide ranges of amplifier and oscillator problems. Low noise and high current capability provide wide dynamic ranges; the excellent linearity of S₂₁ with collector current assures low intermodulation distortion. The NE021 series is available as a chip or in several package styles. The series uses the NEC gold, platinum, titanium, and platinum-silicide metallization system to provide the utmost in reliability. Most package options are available with Grade C (JANTXV equivalent) and Grade CX (JANTX equivalent) reliability screening. Some packages are available in both common-base and common-emitter configurations. The NE02103 and the NE02107 have been qualified for high-reliability space applications.

ABSOLUTE MAXIMUM RATINGS (T_A = 25°C)

SYMBOLS	PARAMETERS	UNITS	RATINGS
V _{cb0}	Collector to Base Voltage	V	25
V _{ce0}	Collector to Emitter Voltage	V	12 ¹
V _{eb0}	Emitter to Base Voltage	V	3
I _c	Collector Current	mA	70
T _J	Junction Temperature	°C	200 ²
T _{stg}	Storage Temperature	°C	-65 to +200 ³

Notes:

1. Typical BV_{CEB} = 25 V for R ≤ 300 Ω.
2. Maximum T_J for the NE02132, NE02133, NE02136, and NE02137 is +150°C.
3. Maximum storage temperature for the NE02132, NE02135, NE02136 and NE02137 is -65 to +150°C. Maximum storage temperature for the NE02133 is -55 to +150°C.

NE02135 TYPICAL NOISE PARAMETERS

V_{CE} = 10 V, I_c = 5 mA

FREQUENCY (MHz)	NF _{min} (dB)	GA	OPT SOURCE	R _n /50 Ω
500	1.2	18.6	.36 ∠ 69°	.14
1000	1.5	13.9	.31 ∠ 124°	.12
1500	2.0	12.1	.50 ∠ 165°	.05
2000	2.4	9.6	.44 ∠ -175°	.06
2500	2.6	8.9	.52 ∠ -161°	.10
3000	3.6	8.6	.68 ∠ -141°	.14
3500	3.7	6.9	.71 ∠ -139°	.21

V_{CE} = 10 V, I_c = 20 mA

500	1.8	20.6	.16 ∠ 149°	.15
1000	1.9	16.1	.33 ∠ 169°	.13
1500	2.4	13.5	.46 ∠ -179°	.09
2000	2.9	11.5	.53 ∠ -167°	.08
2500	3.2	9.8	.57 ∠ -154°	.14
3000	3.9	9.7	.62 ∠ -139°	.27
3500	4.3	7.6	.67 ∠ -134°	.42

PERFORMANCE SPECIFICATIONS (TA = 25°C)

SYMBOLS	PART NUMBER EIAJ ¹ REGISTERED NUMBER PACKAGE OUTLINE	NE02100 00 (CHIP)			NE02103 2SC1560(C) 03			NE02107 07			NE02112 2SC1988 12			NE02132 2SC2570 32			NE02133 2SC2351 33			NE02135 2SC2149 35			NE02137 2SC2369 37		
		PARAMETERS AND CONDITIONS	UNITS	MIN	TYP	MAX	MIN	TYP	MAX	MIN	TYP	MAX	MIN	TYP	MAX	MIN	TYP	MAX	MIN	TYP	MAX	MIN	TYP	MAX	
f _r	Gain Bandwidth Product at V _{CE} = 10 V, I _c = 20 mA	GHz		4.5					4.5					4.5					4.5					4.5	
S ₂₁ ²	Insertion Power Gain at V _{CE} = 10 V, I _c = 20 mA, f = 0.5 GHz f = 1 GHz f = 2 GHz	dB		18.5		13		15		10		8		15		10		9		18.5		13		18.5	
NF _{MIN}	Minimum Noise Figure ² at V _{CE} = 10 V, I _c = 3 mA, f = 0.5 GHz V _{CE} = 10 V, I _c = 5 mA, f = 1 GHz f = 2 GHz	dB	5.5	6.5		5.5	6.5		5.5	6.5		5.5	6.5		5.5	6.5		5	5.7		5	5.7		5	
MAG	Maximum Available Gain ³ at V _{CE} = 10 V, I _c = 20 mA, f = 0.5 GHz f = 1 GHz f = 2 GHz	dB	2.7	4.5		2.7	4.5		2.7	4.5		2.7	4.5		1.5	3		1.5	3		1.5	3		1.5	
		dB	22	18	12	22	18	12	22	18	12	22	18	12	17.5	12.5	7.5	14	14	22	18	11	22	18	11

Notes:

- Electronic Industrial Association of Japan.
- Input and output are tuned for optimum noise figures.
- Maximum Available Gain (MAG) is calculated for the device S-Parameters using the equation, $MAG = |S_{21}|^2 \cdot \frac{1}{1 - |S_{11}|^2} \cdot \frac{1}{1 - |S_{22}|^2}$

ELECTRICAL SPECIFICATIONS (TA = 25°C)

SYMBOLS	PART NUMBER EIAJ ¹ REGISTERED NUMBER PACKAGE OUTLINE	NE02100 00 (CHIP)			NE02103 2SC1560(C) 03			NE02107 07			NE02112 2SC1988 12			NE02132 2SC2570 32			NE02133 2SC2351 33			NE02135 2SC2149 35			NE02137 2SC2369 37		
		PARAMETERS AND CONDITIONS	UNITS	MIN	TYP	MAX	MIN	TYP	MAX	MIN	TYP	MAX	MIN	TYP	MAX	MIN	TYP	MAX	MIN	TYP	MAX	MIN	TYP	MAX	
I _{CO}	Collector Cutoff Current at V _{CB} = 15 V, I _E = 0	μA		1.0					1.0					1.0					1.0					1.0	
I _{EO}	Emitter Cutoff Current at V _{EB} = 2 V, I _C = 0	μA		1.0					1.0					1.0					1.0					1.0	
I _{FE}	Forward Current Gain at V _{CE} = 10 V, I _c = 20 mA		20	70	250	20	70	250	20	70	250	20	70	250	20	70	200	70	250	20	70	250	20	70	
C _{CB}	Collector to Base Capacitance ² at V _{CB} = 10 V, I _E = 0, f = 1 MHz	pF		0.6	1.0		0.6	1.0		0.6	1.0		0.6	1.0		0.7	0.9		0.6	1.0		0.6	1.0		0.75
R _{TH}	Thermal Resistance (μ-C)	°C/W		70		70		90		90				90					120						
R _{TH}	Thermal Resistance (μ-A)			300		300		500		500				500					600						
P _T ³	Total Power Dissipation	mW	580	700	560	700	350	700	350	700	350	700	250	250	290	250	150	290	500	500	500	500	500	250	

Notes:

- Electronic Industrial Association of Japan.
- C_{CB} measurement employs a three-terminal capacitance bridge incorporating a guard circuit. The emitter terminal shall be connected to the guard terminal.
- Minimum dissipation based on R_{TH(μ-A)} for applications without effective heatsink, maximum dissipation based on R_{TH(μ-C)} for applications with effective heatsink.



NE021 SERIES

T-31-17
T-31-19

OUTLINE DIMENSIONS (Units in mm)

NE02100 (CHIP)
(Chip Thickness: 140 μm)

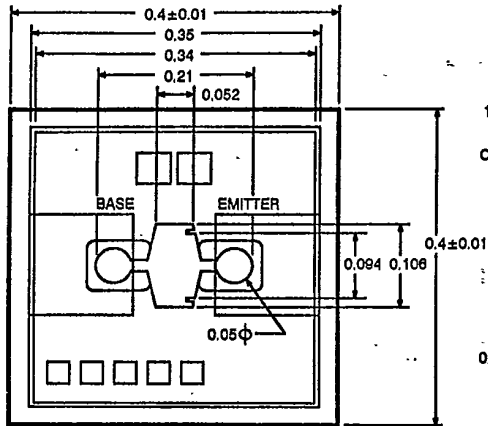

OUTLINE 03

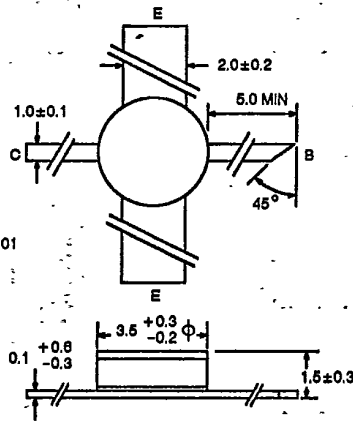

OUTLINE 07

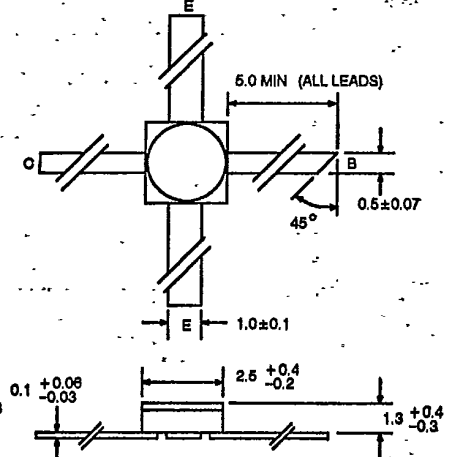

*07B has emitter and base reversed.

OUTLINE 12
(TO-72)

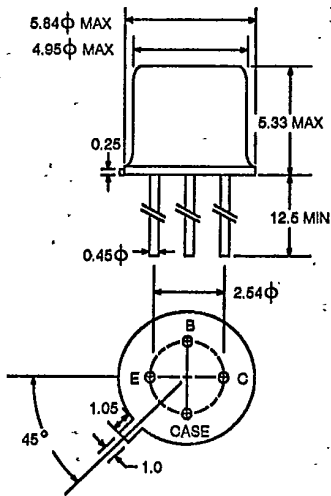

OUTLINE 32
(TO-92)

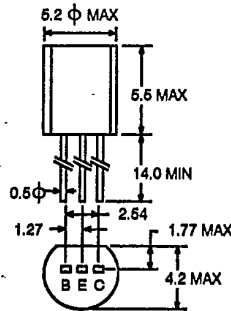

OUTLINE 33
(SOT-23)

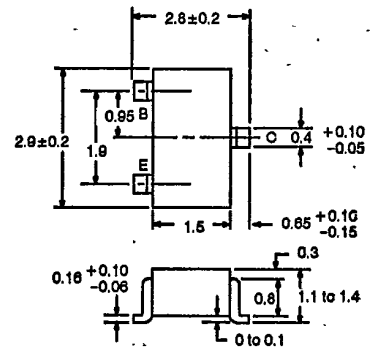

OUTLINE 35
(MICRO-X)

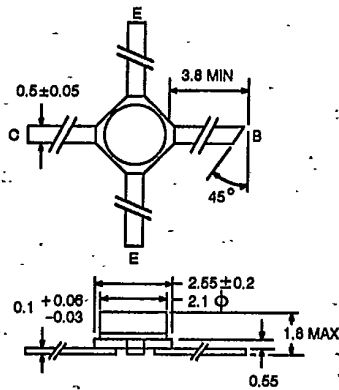

OUTLINE 37

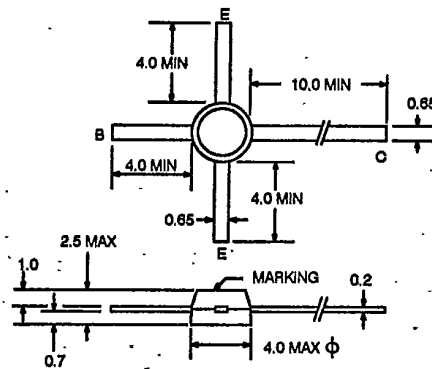

*The NE02136 is available with only the bottom emitter lead.

T-31-17
T-31-19

TYPICAL DEVICE CHARACTERISTICS (TA = 25°C)

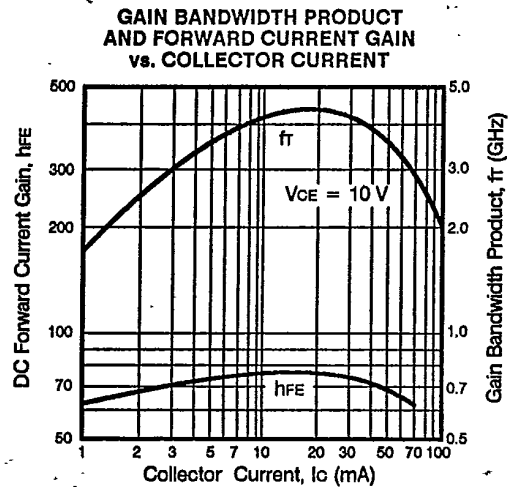
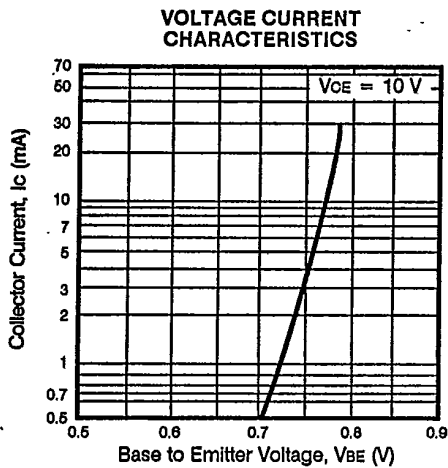
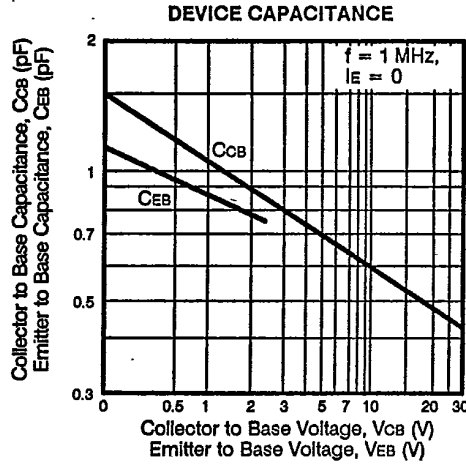
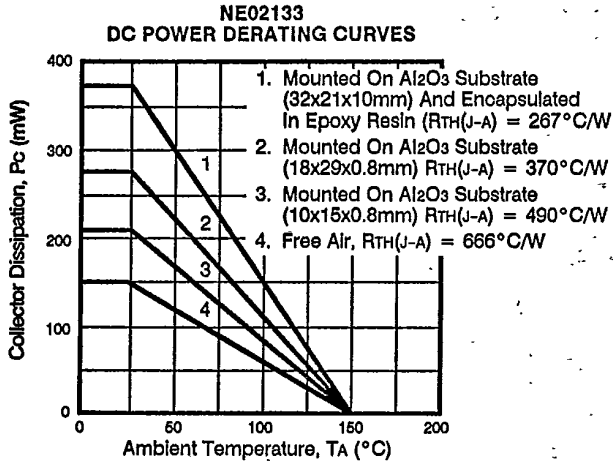
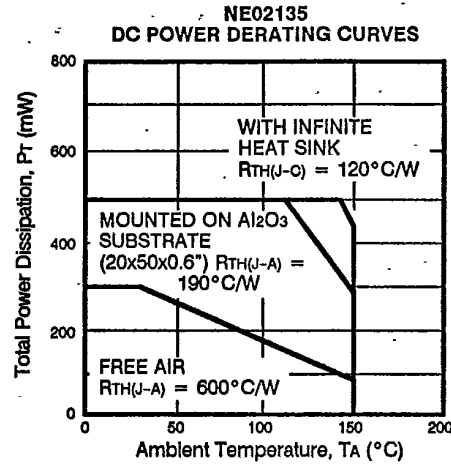
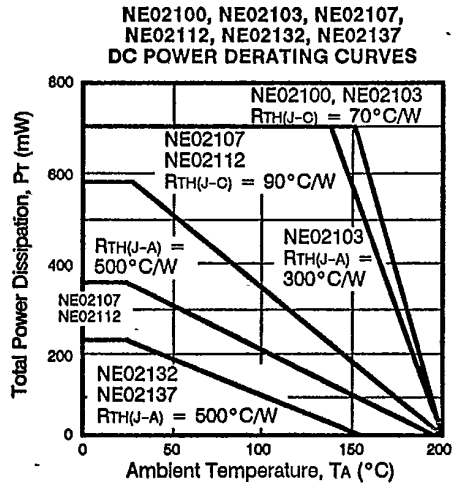

NE021 SERIES

T-31-17
T-31-19

TYPICAL PERFORMANCE CHARACTERISTICS (T_A = 25°C)

NE02103, NE02107, NE02135
GAIN vs. FREQUENCY

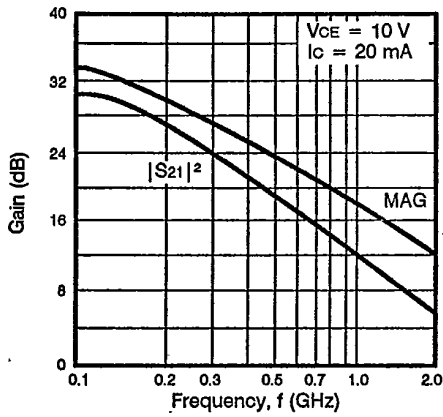

NE02112, NE02133
GAIN vs. FREQUENCY

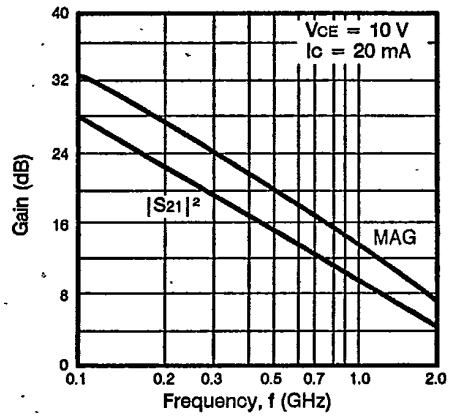

NE02103, NE02107
INSERTION GAIN vs. COLLECTOR CURRENT

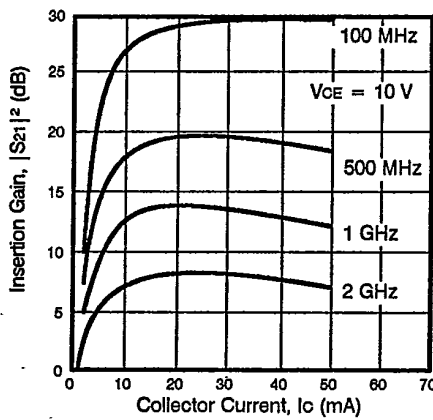

NOISE FIGURE vs. COLLECTOR CURRENT

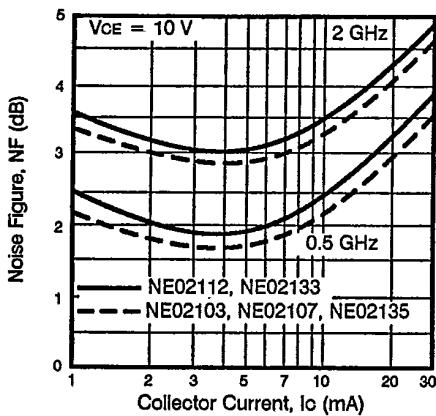

NOISE FIGURE AND ASSOCIATED GAIN vs. FREQUENCY

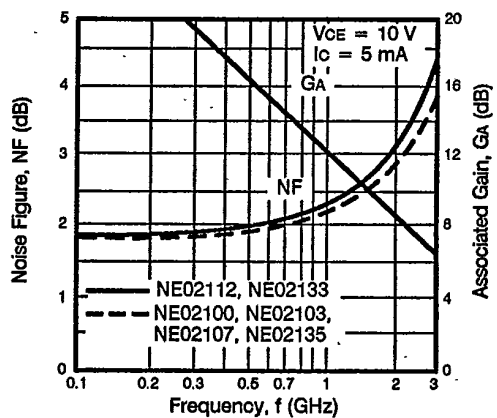

TYPICAL COMMON EMITTER SCATTERING PARAMETERS

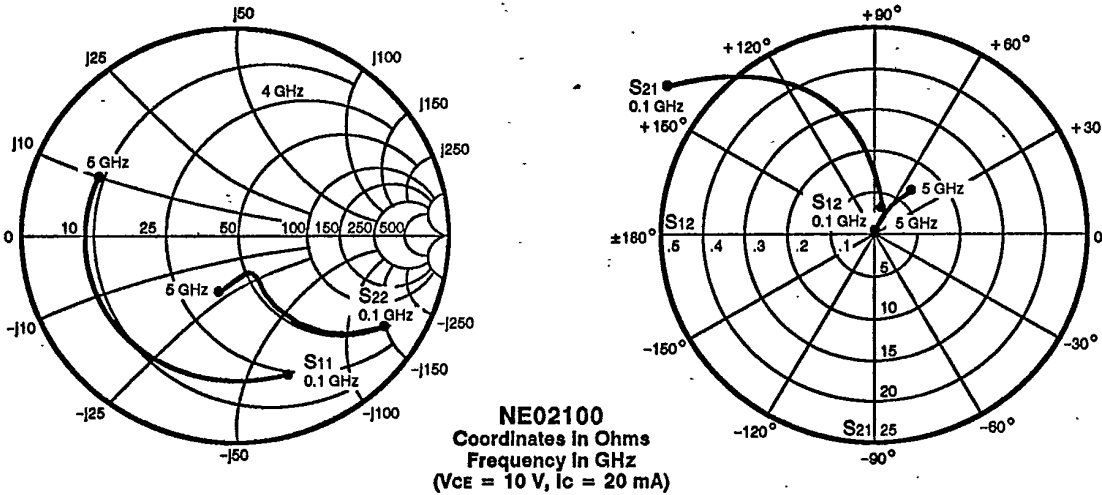

S-MAGN AND ANGLES:

VCE = 10 V, IC = 5 mA

FREQUENCY (MHz)	S11	S21	S12	S22	k	GMA dB
100	.84 -32	11.83 160	.03 70	.94 -16	.11	26.4
500	.75 -114	7.22 113	.07 36	.56 -45	.29	19.9
1000	.73 -150	4.13 89	.09 27	.39 -51	.54	16.9
1500	.71 -164	2.85 76	.09 27	.35 -56	.77	15.0
2000	.71 -173	2.16 66	.10 28	.33 -61	.97	13.5
2500	.71 -179	1.75 57	.10 30	.33 -67	1.14	10.1
3000	.70 176	1.49 49	.11 32	.34 -73	1.25	8.3
3500	.70 172	1.28 42	.12 33	.35 -80	1.35	6.9
4000	.70 168	1.13 34	.12 34	.37 -88	1.41	5.9
4500	.70 165	1.02 27	.13 34	.39 -94	1.47	4.9
5000	.70 161	.92 20	.14 35	.41 -100	1.49	4.2

VCE = 10 V, IC = 10 mA

100	.75 -47	20.04 153	.02 65	.89 -24	.11	29.2
500	.72 -137	9.40 105	.05 34	.41 -57	.39	22.5
1000	.72 -162	4.97 86	.06 34	.27 -62	.69	19.0
1500	.71 -173	3.37 75	.07 38	.23 -66	.92	16.8
2000	.71 -179	2.56 66	.08 41	.22 -71	1.09	13.2
2500	.71 176	2.05 58	.09 43	.23 -76	1.19	10.9
3000	.71 172	1.74 51	.10 44	.24 -82	1.27	9.2
3500	.71 168	1.50 44	.11 44	.25 -88	1.31	7.9
4000	.70 165	1.33 37	.12 44	.27 -95	1.36	6.8
4500	.70 162	1.19 30	.13 44	.29 -100	1.39	5.9
5000	.70 159	1.08 24	.14 43	.31 -106	1.39	5.1

VCE = 10 V, IC = 20 mA

100	.68 -70	29.75 145	.02 59	.81 -33	.14	31.6
500	.72 -152	10.58 99	.04 37	.30 -65	.53	24.3
1000	.72 -170	5.42 84	.05 43	.19 -69	.87	20.4
1500	.72 -178	3.65 74	.06 48	.17 -73	1.05	16.4
2000	.72 177	2.74 66	.07 50	.17 -78	1.17	13.2
2500	.72 172	2.21 58	.09 51	.17 -83	1.23	11.3
3000	.71 169	1.86 51	.10 52	.19 -87	1.27	9.7
3500	.71 166	1.61 44	.11 51	.20 -93	1.30	8.4
4000	.71 162	1.42 38	.12 51	.22 -99	1.34	7.3
4500	.71 160	1.28 31	.13 49	.24 -105	1.33	6.4
5000	.71 157	1.15 25	.14 48	.27 -109	1.34	5.6

NOTE: S-Parameters include bond wires.
 BASE: Total 1 wire (s), 1 per bond pad, 0.0115" (291 μm) long each wire.
 COLLECTOR: Total 1 wire (s), 1 per bond pad, 0.0072" (182 μm) long each wire.
 EMITTER: Total 2 wire (s), 1 per side, 0.015" (393 μm) long each wire.
 WIRE: 0.0007" (17.7 μm) dia., gold.



TYPICAL COMMON EMITTER SCATTERING PARAMETERS

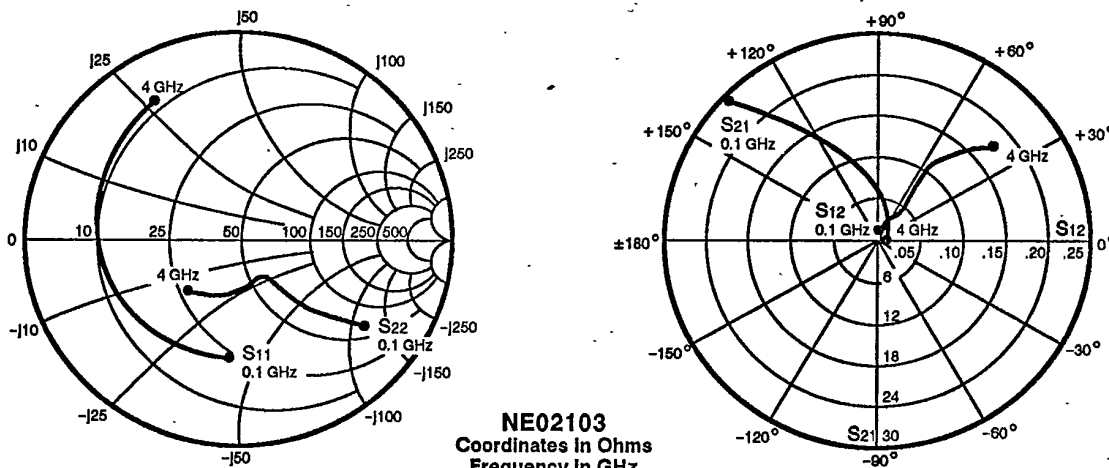

NE02103
Coordinates in Ohms
Frequency in GHz
(VCE = 10 V, IC = 20 mA)

S-MAGN AND ANGLES:

VCE = 10 V, IC = 5 mA

FREQUENCY (MHz)	S11		S21		S12		S22	
100	.82	-41	13.67	154	.02	72	.92	-17
500	.67	-133	6.53	103	.07	34	.51	-43
1000	.66	-167	3.58	79	.08	31	.38	-51
1500	.65	175	2.45	63	.10	32	.37	-61
2000	.66	163	1.85	51	.11	36	.37	-71
2500	.67	151	1.49	38	.12	34	.36	-83
3000	.68	141	1.29	26	.14	35	.38	-98
3500	.69	132	1.09	16	.16	32	.40	-110
4000	.71	124	.96	5	.16	29	.43	-121

VCE = 10 V, IC = 10 mA

100	.69	-62	21.74	145	.01	68	.84	-25
500	.65	-154	7.92	96	.05	39	.36	-49
1000	.65	-179	4.15	76	.07	43	.27	-55
1500	.65	168	2.81	62	.08	47	.27	-63
2000	.66	158	2.12	51	.11	49	.28	-74
2500	.68	146	1.70	39	.12	44	.28	-88
3000	.69	138	1.46	28	.14	43	.30	-102
3500	.71	129	1.23	17	.17	40	.33	-115
4000	.72	121	1.09	7	.17	34	.35	-126

VCE = 10 V, IC = 20 mA

100	.57	-91	29.51	136	.01	65	.74	-33
500	.65	-167	8.77	91	.04	48	.27	-54
1000	.66	175	4.49	74	.06	54	.20	-60
1500	.66	164	3.05	61	.08	54	.21	-68
2000	.68	154	2.27	51	.10	55	.22	-78
2500	.69	144	1.83	39	.13	50	.23	-93
3000	.70	136	1.56	29	.14	45	.25	-107
3500	.72	127	1.30	19	.16	42	.28	-118
4000	.74	120	1.18	9	.18	39	.31	-130

VCE = 10 V, IC = 40 mA

100	.53	-121	34.50	128	.01	66	.66	-38
500	.66	-175	9.00	88	.03	61	.23	-50
1000	.67	171	4.56	72	.05	63	.17	-55
1500	.68	161	3.07	60	.08	59	.19	-64
2000	.69	152	2.30	50	.10	60	.21	-75
2500	.71	142	1.85	39	.13	54	.21	-92
3000	.72	135	1.59	29	.14	47	.24	-108
3500	.74	126	1.33	19	.16	45	.26	-119
4000	.75	119	1.18	8	.17	42	.30	-131

TYPICAL COMMON BASE SCATTERING PARAMETERS

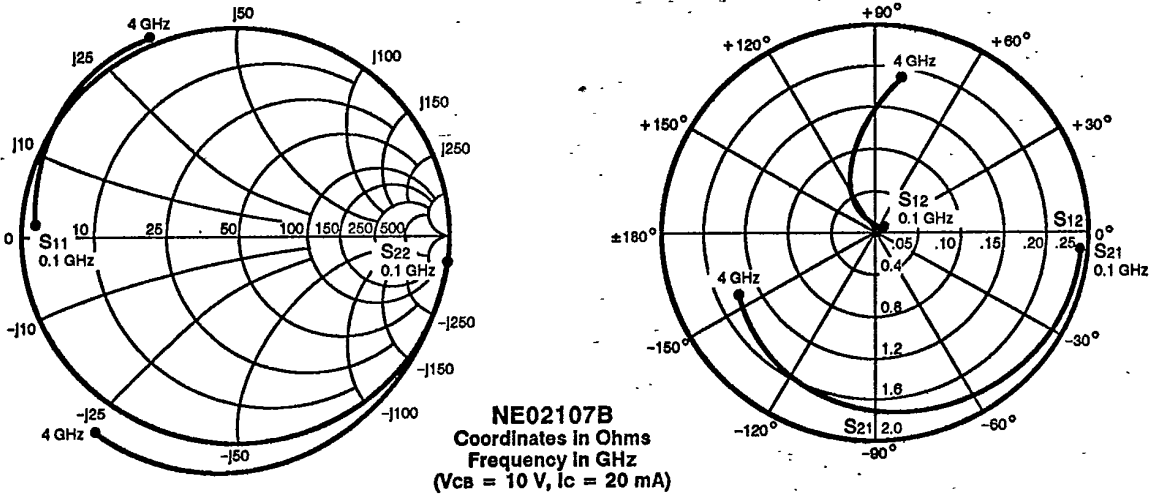

S-MAGN AND ANGLES:

V_{CB} = 10 V, I_C = 5 mA

FREQUENCY (MHz)

	S ₁₁	S ₂₁	S ₁₂	S ₂₂
100	.79 175	1.77 -10	.01 106	1.01 -9
500	.79 170	1.78 -24	.01 111	1.02 -22
1000	.79 163	1.72 -44	.01 117	1.05 -40
1500	.83 157	1.71 -64	.03 109	1.09 -58
2000	.83 149	1.57 -87	.06 106	1.09 -75
2500	.87 145	1.53 -99	.08 103	1.08 -81
3000	.87 136	1.40 -122	.11 95	1.11 -96
3500	.87 126	1.21 -140	.13 86	1.10 -111
4000	.86 117	1.12 -164	.17 76	1.08 -125

V_{CB} = 10 V, I_C = 10 mA

100	.88 177	1.84 -6	.01 -31	1.01 -6
500	.88 171	1.84 -19	.01 112	1.00 -18
1000	.87 164	1.83 -38	.01 132	1.05 -36
1500	.90 169	1.82 -57	.03 118	1.08 -53
2000	.92 152	1.72 -76	.06 117	1.10 -69
2500	.95 144	1.68 -92	.08 108	1.09 -81
3000	.96 135	1.57 -113	.12 98	1.13 -96
3500	.96 126	1.45 -135	.15 88	1.12 -111
4000	.95 116	1.33 -156	.18 77	1.10 -126

V_{CB} = 10 V, I_C = 20 mA

100	.92 176	1.90 -6	.01 56	1.02 -6
500	.93 171	1.89 -19	.01 139	1.01 -18
1000	.92 164	1.89 -37	.01 129	1.05 -36
1500	.96 159	1.88 -55	.03 126	1.09 -53
2000	.97 152	1.81 -75	.06 119	1.10 -69
2500	1.01 142	1.75 -90	.09 110	1.09 -80
3000	1.02 132	1.67 -110	.12 100	1.13 -95
3500	1.03 121	1.55 -132	.15 89	1.13 -110
4000	1.02 112	1.42 -154	.18 79	1.12 -125

V_{CB} = 10 V, I_C = 40 mA

100	.95 176	1.93 -7	.01 -74	1.02 -7
500	.94 171	1.91 -20	.01 116	1.01 -19
1000	.94 163	1.91 -38	.01 133	1.05 -36
1500	.98 158	1.90 -57	.03 126	1.09 -53
2000	.99 151	1.83 -77	.06 119	1.10 -69
2500	1.04 141	1.81 -92	.09 111	1.09 -81
3000	1.05 132	1.72 -115	.12 100	1.13 -97
3500	1.05 120	1.58 -136	.15 88	1.13 -113
4000	1.03 111	1.46 -157	.18 77	1.10 -127



TYPICAL COMMON EMITTER SCATTERING PARAMETERS

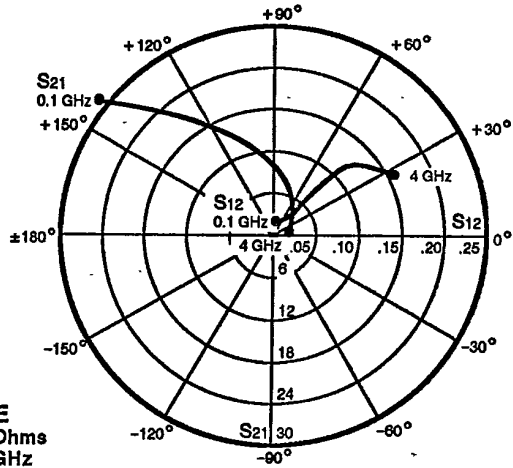
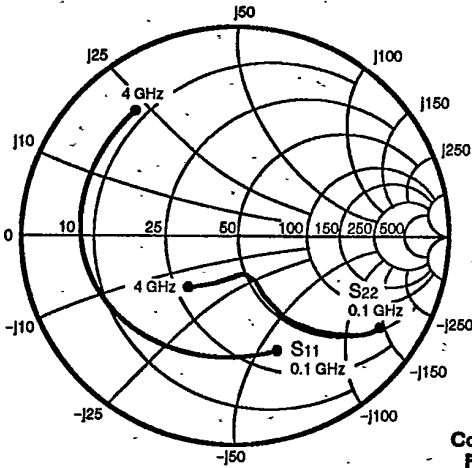

NE02107E
Coordinates in Ohms
Frequency in GHz
(VCE = 10 V, IC = 20 mA)

S-MAGN AND ANGLES:

VCE = 10 V, IC = 5 mA

FREQUENCY (MHz)

	S11	S21	S12	S22
100	.82 -36	13.90 157	.01 73	.95 -16
500	.70 -125	7.38 107	.07 35	.54 -47
1000	.68 -161	4.17 82	.08 25	.39 -59
1500	.68 -178	2.87 66	.09 24	.38 -68
2000	.68 170	2.18 53	.10 26	.37 -78
2500	.67 159	1.73 40	.11 22	.38 -90
3000	.67 151	1.49 28	.12 23	.40 -102
3500	.68 142	1.27 17	.13 19	.43 -112
4000	.68 134	1.16 6	.14 17	.45 -122

VCE = 10 V, IC = 10 mA

100	.69 -54	22.57 150	.01 69	.89 -23
500	.67 -145	9.37 100	.05 36	.39 -58
1000	.67 -172	5.00 79	.06 36	.27 -70
1500	.67 175	3.40 65	.08 37	.26 -77
2000	.67 165	2.57 53	.09 40	.25 -87
2500	.67 154	2.07 41	.11 35	.28 -97
3000	.67 146	1.80 30	.12 34	.31 -108
3500	.67 137	1.53 20	.14 30	.34 -116
4000	.67 130	1.41 8	.15 23	.36 -125

VCE = 10 V, IC = 20 mA

100	.58 -79	31.63 142	.01 65	.81 -32
500	.67 -161	10.57 95	.03 45	.28 -68
1000	.67 179	5.47 77	.04 46	.19 -78
1500	.67 168	3.70 64	.07 46	.19 -84
2000	.67 159	2.78 53	.09 48	.20 -96
2500	.67 150	2.26 42	.11 44	.23 -105
3000	.68 142	1.96 31	.12 39	.25 -114
3500	.67 134	1.68 21	.14 36	.28 -122
4000	.68 127	1.53 9	.16 27	.31 -128

VCE = 10 V, IC = 30 mA

100	.55 -96	35.99 137	.01 63	.75 -37
500	.67 -167	10.79 93	.02 48	.24 -69
1000	.68 176	5.52 75	.04 53	.17 -77
1500	.68 166	3.75 63	.07 52	.17 -83
2000	.68 158	2.81 52	.09 53	.18 -96
2500	.68 148	2.26 41	.11 46	.21 -106
3000	.68 141	1.96 30	.13 42	.24 -115
3500	.68 133	1.66 20	.14 38	.27 -123
4000	.68 126	1.51 9	.16 29	.30 -131

TYPICAL COMMON EMITTER SCATTERING PARAMETERS

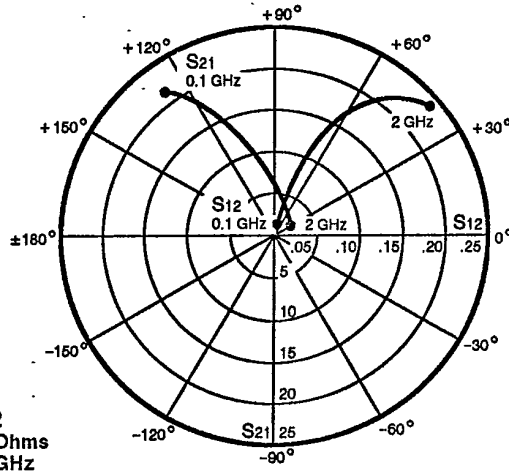
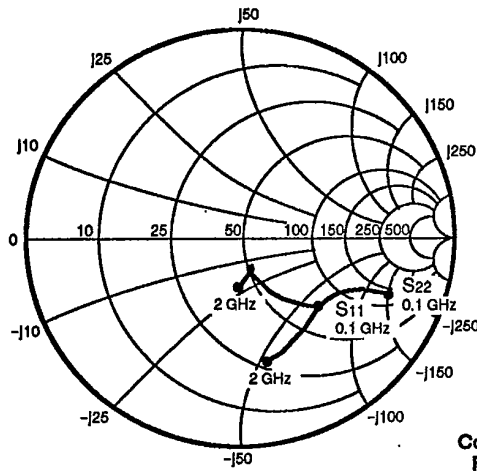

NE02112
Coordinates in Ohms
Frequency in GHz
(VCE = 10 V, IC = 20 mA)



S-MAGN AND ANGLES:

VCE = 10 V, IC = 5 mA

FREQUENCY (MHz)

	S11		S21		S12		S22	
100	.76	-31	12.27	147	.01	69	.89	-16
200	.61	-52	9.59	126	.04	64	.78	-25
500	.33	-87	5.07	94	.09	61	.61	-36
1000	.17	-113	2.80	68	.15	60	.55	-47
1500	.14	-112	1.99	48	.20	53	.57	-63
2000	.18	-107	1.52	28	.22	40	.63	-82

VCE = 10 V, IC = 10 mA

100	.61	-37	17.41	136	.01	69	.81	-20
200	.45	-56	11.92	116	.03	69	.68	-26
500	.23	-82	5.64	88	.09	68	.54	-34
1000	.13	-94	3.03	66	.16	63	.51	-45
1500	.14	-90	2.13	47	.21	52	.53	-62
2000	.22	-96	1.62	27	.24	38	.60	-80

VCE = 10 V, IC = 20 mA

100	.47	-41	21.28	127	.01	76	.73	-21
200	.33	-56	13.15	108	.03	71	.62	-25
500	.18	-76	5.87	85	.09	70	.51	-32
1000	.11	-81	3.12	64	.16	64	.49	-43
1500	.14	-80	2.18	46	.22	53	.53	-61
2000	.23	-91	1.66	26	.24	38	.60	-80

VCE = 10 V, IC = 40 mA

100	.37	-49	21.89	119	.01	71	.68	-19
200	.25	-64	12.81	103	.02	71	.60	-21
500	.13	-89	5.52	82	.09	71	.53	-28
1000	.07	-99	2.93	62	.16	65	.52	-41
1500	.10	-87	2.06	44	.21	53	.55	-59
2000	.18	-94	1.56	24	.23	39	.62	-79

T-31-17

TYPICAL COMMON EMITTER SCATTERING PARAMETERS

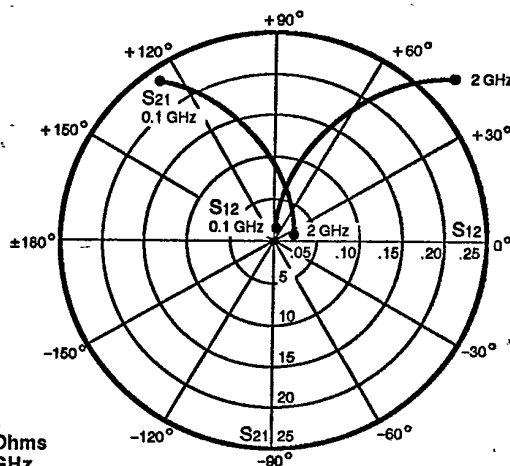
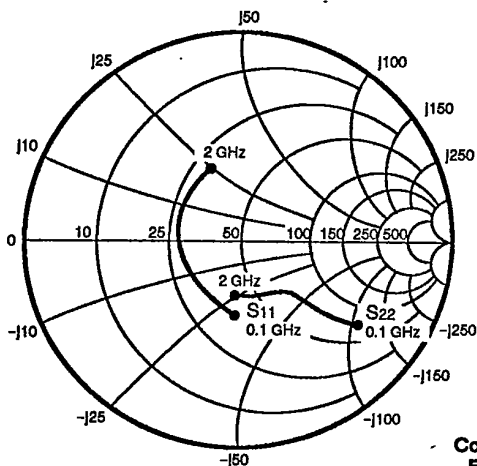

NE02132
Coordinates in Ohms
Frequency in GHz
(VCE = 10 V, IC = 20 mA)

S-MAGN AND ANGLES:

VCE = 10 V, IC = 5 mA

FREQUENCY (MHz)

	S11		S21		S12		S22	
100	.70	-45	12.65	145	.03	71	.88	-21
200	.54	-80	9.63	123	.05	55	.70	-34
500	.39	-136	5.06	92	.09	53	.46	-47
1000	.35	176	2.77	63	.14	52	.40	-57
1500	.36	145	1.97	44	.20	51	.37	-72
2000	.41	120	1.62	25	.26	43	.36	-88

VCE = 10 V, IC = 10 mA

100	.50	-64	18.88	135	.02	69	.78	-29
200	.37	-105	12.46	113	.03	57	.56	-40
500	.31	-155	5.84	86	.09	64	.35	-48
1000	.30	163	3.12	62	.15	58	.32	-57
1500	.32	136	2.20	44	.22	53	.30	-73
2000	.37	114	1.80	26	.28	42	.29	-89

VCE = 10 V, IC = 20 mA

100	.34	-90	23.82	125	.01	71	.67	-34
200	.27	-133	14.23	105	.03	66	.45	-42
500	.27	-171	6.24	83	.09	70	.29	-46
1000	.29	155	3.31	60	.16	62	.28	-55
1500	.30	131	2.32	43	.23	54	.26	-74
2000	.35	111	1.88	26	.29	42	.26	-90

VCE = 10 V, IC = 40 mA

100	.27	-118	26.55	117	.01	73	.57	-36
200	.26	-156	14.82	100	.02	75	.38	-39
500	.27	179	6.32	81	.09	74	.27	-41
1000	.29	151	3.33	59	.16	63	.27	-53
1500	.31	128	2.34	43	.23	55	.26	-71
2000	.36	109	1.89	25	.29	42	.25	-88

TYPICAL COMMON EMITTER SCATTERING PARAMETERS

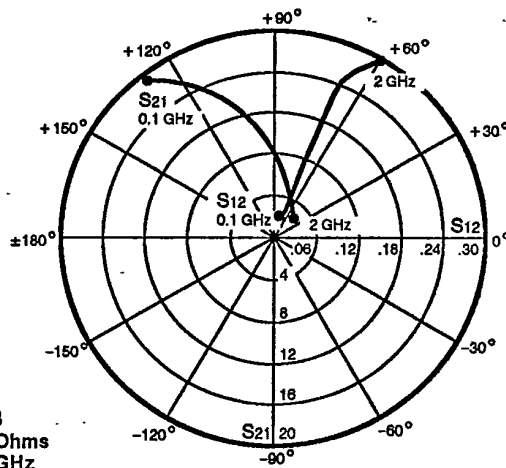
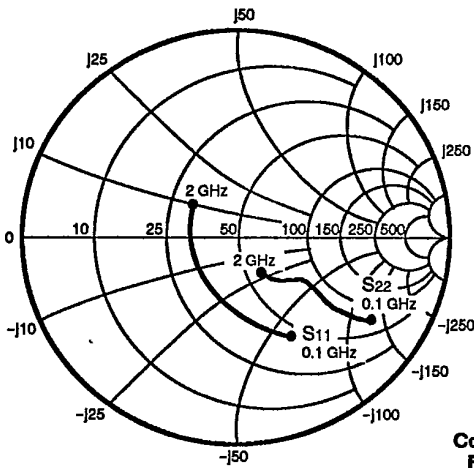

NE02133
Coordinates in Ohms
Frequency in GHz
(VCE = 10 V, IC = 20 mA)



S-MAGN AND ANGLES:

VCE = 10 V, IC = 5 mA

FREQUENCY (MHz)

	S11	S21	S12	S22
100	.80 -37	13.53 150	.03 73	.91 -18
200	.63 -63	10.48 129	.04 59	.72 -29
500	.37 -114	5.56 99	.09 61	.48 -38
1000	.27 -158	3.02 76	.15 60	.40 -41
1500	.27 172	2.16 63	.21 63	.34 -49
2000	.29 151	1.74 49	.27 58	.31 -62

VCE = 10 V, IC = 10 mA

	S11	S21	S12	S22
100	.66 -48	19.53 139	.02 79	.81 -27
200	.46 -78	13.52 118	.03 58	.58 -35
500	.27 -129	6.29 93	.09 67	.38 -36
1000	.21 -169	3.31 74	.16 66	.34 -40
1500	.23 165	2.35 62	.23 64	.29 -47
2000	.26 146	1.87 50	.29 59	.26 -62

VCE = 10 V, IC = 20 mA

	S11	S21	S12	S22
100	.51 -61	19.37 129	.02 79	.70 -32
200	.33 -91	15.04 109	.03 64	.48 -35
500	.21 -143	6.57 89	.08 71	.33 -32
1000	.19 -177	3.41 72	.16 69	.32 -37
1500	.21 160	2.41 61	.24 67	.26 -45
2000	.24 142	1.92 49	.30 59	.23 -59

TYPICAL COMMON EMITTER SCATTERING PARAMETERS

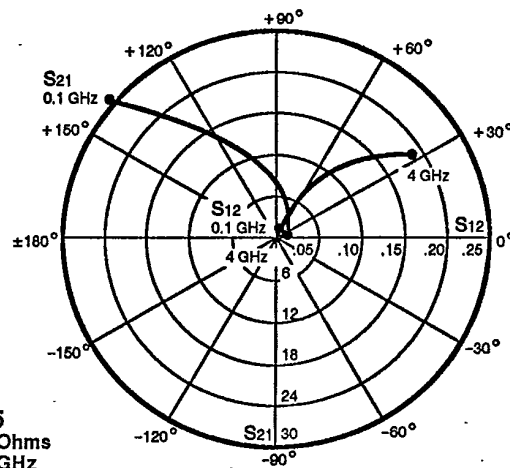
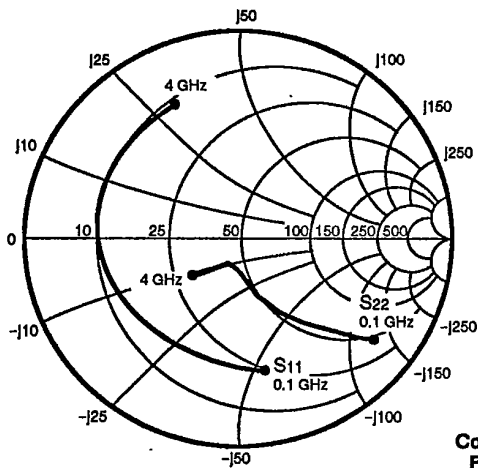

NE02135
Coordinates in Ohms
Frequency in GHz
(V_{CE} = 10 V, I_C = 20 mA)

S-MAGN AND ANGLES:

V_{CE} = 10 V, I_C = 5 mA

FREQUENCY (MHz)

	S ₁₁	S ₂₁	S ₁₂	S ₂₂
100	.84 -36	13.82 156	.02 73	.94 -18
500	.68 -126	7.18 106	.08 35	.51 -53
1000	.66 -163	4.02 81	.09 27	.34 -66
1500	.65 178	2.75 64	.10 27	.31 -74
2000	.65 163	2.10 52	.12 30	.31 -83
2500	.66 151	1.68 39	.13 26	.31 -95
3000	.66 141	1.46 27	.14 26	.33 -106
3500	.67 129	1.24 17	.16 26	.36 -116
4000	.68 121	1.14 5	.17 23	.38 -127

V_{CE} = 10 V, I_C = 10 mA

100	.73 -55	22.55 148	.02 65	.87 -27
500	.64 -148	8.90 98	.06 37	.36 -66
1000	.64 -176	4.71 77	.07 39	.23 -82
1500	.64 169	3.19 63	.09 40	.21 -87
2000	.65 156	2.42 52	.11 42	.21 -97
2500	.65 145	1.95 40	.13 37	.22 -108
3000	.66 135	1.69 29	.15 35	.25 -118
3500	.66 125	1.43 19	.17 32	.27 -127
4000	.68 117	1.34 8	.19 28	.29 -137

V_{CE} = 10 V, I_C = 20 mA

100	.62 -80	31.13 139	.01 60	.77 -37
500	.64 -163	9.88 93	.04 46	.26 -79
1000	.65 176	5.07 75	.06 49	.16 -95
1500	.64 164	3.45 63	.08 50	.15 -101
2000	.65 154	2.60 52	.11 51	.16 -111
2500	.66 142	2.10 40	.13 43	.18 -121
3000	.66 133	1.81 30	.15 40	.20 -129
3500	.66 122	1.55 20	.17 36	.22 -136
4000	.68 115	1.43 8	.19 31	.25 -144

V_{CE} = 10 V, I_C = 30 mA

100	.58 -95	35.35 134	.01 59	.72 -40
500	.64 -169	10.11 91	.03 50	.22 -82
1000	.65 173	5.15 74	.06 55	.14 -97
1500	.65 162	3.49 62	.08 53	.14 -103
2000	.66 152	2.63 52	.11 54	.15 -112
2500	.66 141	2.10 39	.13 46	.17 -122
3000	.66 132	1.82 29	.15 42	.19 -129
3500	.67 122	1.54 20	.17 38	.22 -137
4000	.68 115	1.44 9	.20 31	.24 -146

TYPICAL COMMON EMITTER SCATTERING PARAMETERS

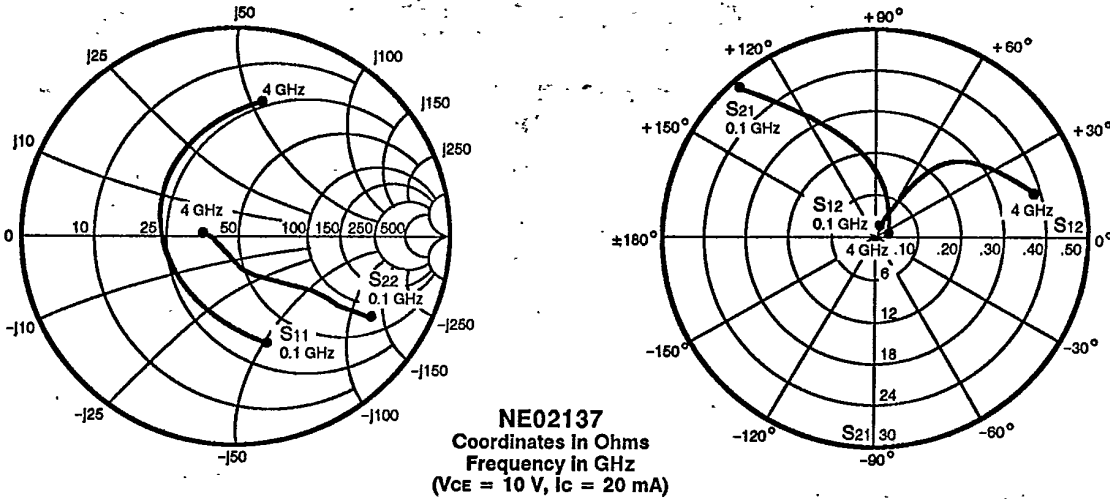

S-MAGN AND ANGLES:

VCE = 10 V, IC = 5 mA

FREQUENCY (MHz)

	S11		S21		S12		S22	
100	.81	-36	13.62	152	.02	72	.92	-17
500	.46	-127	6.36	98	.08	48	.50	-39
1000	.42	-176	3.51	72	.11	48	.38	-46
1500	.43	154	2.43	53	.15	46	.35	-54
2000	.46	133	1.87	39	.19	44	.33	-65
2500	.53	113	1.54	23	.23	37	.24	-86
3000	.58	100	1.33	9	.27	31	.23	-112
3500	.61	88	1.15	-1	.31	23	.21	-144
4000	.65	79	1.04	-16	.35	16	.26	-155

VCE = 10 V, IC = 10 mA

100	.66	-52	21.54	142	.02	72	.83	-24
500	.37	-149	7.49	91	.07	56	.38	-39
1000	.37	170	3.96	69	.11	57	.29	-45
1500	.39	146	2.71	53	.16	52	.27	-53
2000	.43	128	2.08	39	.21	47	.24	-67
2500	.51	109	1.70	24	.25	38	.17	-91
3000	.56	97	1.46	10	.29	30	.15	-123
3500	.60	86	1.25	-0	.32	22	.15	-159
4000	.63	77	1.15	-14	.36	14	.19	-171

VCE = 10 V, IC = 20 mA

100	.51	-73	28.85	131	.01	69	.72	-30
500	.34	-167	8.09	87	.06	64	.31	-36
1000	.36	161	4.18	67	.11	63	.24	-42
1500	.38	140	2.85	52	.17	54	.22	-52
2000	.41	124	2.19	38	.22	50	.20	-66
2500	.50	107	1.78	24	.26	39	.12	-94
3000	.55	96	1.52	11	.30	30	.12	-133
3500	.58	84	1.31	0	.32	22	.12	-177
4000	.62	77	1.20	-13	.37	14	.17	-179

VCE = 10 V, IC = 30 mA

100	.45	-88	31.67	125	.01	70	.66	-32
500	.33	-174	8.10	85	.06	67	.29	-33
1000	.36	158	4.16	66	.11	64	.24	-40
1500	.39	139	2.84	51	.16	56	.22	-50
2000	.42	123	2.18	38	.22	50	.20	-63
2500	.50	106	1.77	23	.26	39	.12	-91
3000	.55	95	1.51	9	.30	30	.11	-130
3500	.58	85	1.29	0	.32	24	.07	-163
4000	.62	76	1.20	-12	.36	14	.16	-180

