

2SC2118

Fig. P_o TEST CIRCUIT

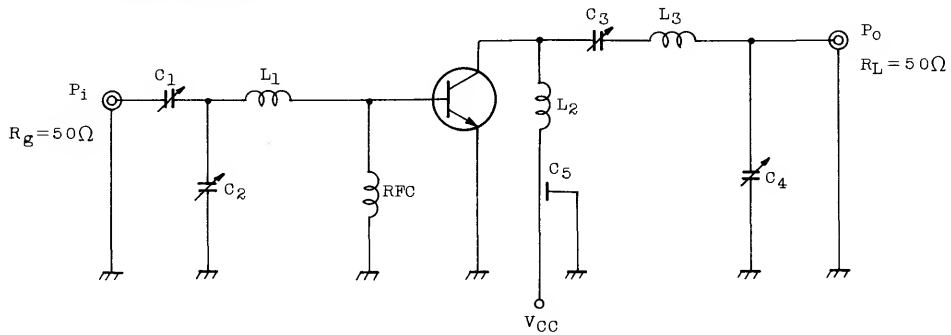

C_1, C_2, C_3, C_4 : $\sim 30\text{pF}$

C_5 : 1000pF FEED THROUGH

L_1, L_2 : $\phi 1.2$ SILVER PLATED COPPER WIRE, 8ID, 1T

L_3 : $\phi 1.2$ SILVER PLATED COPPER WIRE, 8ID, 7/4T

RFC : $1\mu\text{H}$ CHOKE COIL

