

INDUSTRIAL APPLICATIONS

SWITCHING REGULATOR AND HIGH VOLTAGE
SWITCHING APPLICATIONS.
HIGH SPEED DC-DC CONVERTER APPLICATIONS.

FEATURES:

- Excellent Switching Time ($I_C=3A$)
: $t_r=1.0\mu s$ Max. $t_f=1.0\mu s$ Max.
- High Collector Breakdown Voltage : $V_{CEO}=400V$

MAXIMUM RATINGS (Ta=25°C)

CHARACTERISTIC	SYMBOL	RATING	UNIT
Collector-Base Voltage	V_{CBO}	500	V
Collector-Emitter Voltage	V_{CEO}	400	V
Emitter-Base Voltage	V_{EBO}	7	V
Collector Current	I_C	7	A
Base Current	I_B	3	A
Collector Power Dissipation (Tc=25°C)	P_C	40	W
Junction Temperature	T_j	150	°C
Storage Temperature Range	T_{stg}	-65~150	°C

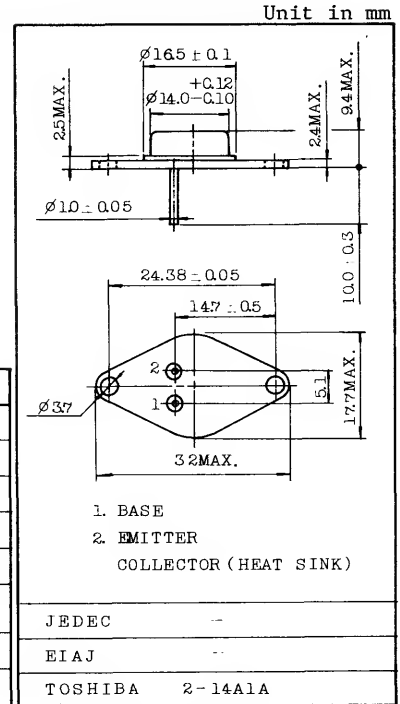

Mounting Kit No. AC74
Weight : 7.6g

ELECTRICAL CHARACTERISTICS (Ta=25°C)

CHARACTERISTIC	SYMBOL	TEST CONDITION	MIN.	TYP.	MAX.	UNIT
Collector Cut-off Current	I_{CBO}	$V_{CB}=400V, I_E=0$	-	-	100	μA
Emitter Cut-off Current	I_{EBO}	$V_{EB}=7V, I_C=0$	-	-	1	mA
Collector-Base Breakdown Voltage	$V_{(BR)CBO}$	$I_C=1mA, I_E=0$	500	-	-	V
Collector-Emitter Breakdown Voltage	$V_{(BR)CEO}$	$I_C=10mA, I_B=0$	400	-	-	V
Emitter-Base Breakdown Voltage	$V_{(BR)EBO}$	$I_E=1mA, I_C=0$	7	-	-	V
DC Current Gain	h_{FE}	$V_{CE}=5V, I_C=3A$	10	-	-	-
Collector-Emitter Saturation Voltage	$V_{CE(sat)}$	$I_C=3A, I_B=0.3A$	-	-	1.5	V
Base-Emitter Saturation Voltage	$V_{BE(sat)}$	$I_C=3A, I_B=0.3A$	-	-	2.0	V
Switching Time	Rise Time	t_r	-	-	1.0	μs
	Storage Time	t_{stg}	-	-	2.0	
	Fall Time	t_f	-	-	1.0	

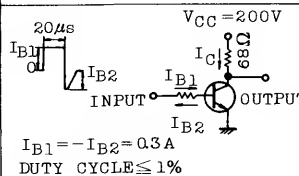

2SC2200

