

用途:用于电视机末级图像中放。

Purpose: TV final picture IF amplifier applications.

特点:高增益, h_{FE} 线性好。

Features: High gain, good h_{FE} linearity.

极限参数/Absolute maximum ratings($T_a=25^\circ\text{C}$)

参数符号 Symbol	数值 Rating	单位 Unit
V_{CB0}	50	V
V_{CE0}	45	V
V_{EB0}	4.0	V
I_C	50	mA
I_E	-50	mA
P_C	300	mW
T_j	150	$^\circ\text{C}$
T_{stg}	-55~150	$^\circ\text{C}$

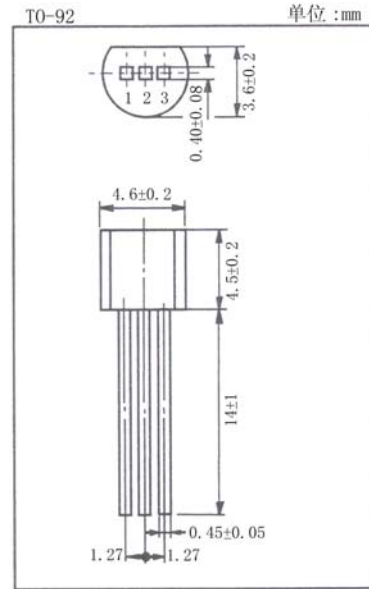

引脚: 1. B 2. E 3. C

电性能参数/Electrical characteristics($T_a=25^\circ\text{C}$)

参数符号 Symbol	测试条件 Test condition	数值 Rating			单位 Unit
		最小值 Min	典型值 Typ	最大值 Max	
V_{CE0}	$I_C=10\text{mA}$ $I_B=0$	45			V
I_{CB0}	$V_{CB}=50\text{V}$ $I_E=0$			0.1	μA
I_{EB0}	$V_{EB}=3.0\text{V}$ $I_C=0$			0.1	μA
h_{FE}	$V_{CE}=12.5\text{V}$ $I_C=12.5\text{mA}$	40		140	
$V_{CE(sat)}$	$I_C=15\text{mA}$ $I_B=1.5\text{mA}$			0.2	V
$V_{BE(sat)}$	$I_C=15\text{mA}$ $I_B=1.5\text{mA}$			1.5	V
f_T	$V_{CE}=12.5\text{V}$ $I_C=12.5\text{mA}$	300			MHz
C_{ob}	$V_{CB}=10\text{V}$ $I_E=0$ $f=30\text{MHz}$	0.8		2.0	pF
G_{pe}	$V_{CC}=12.5\text{V}$ $I_E=-12.5\text{mA}$ $f=45\text{MHz}$	29		36	dB
C_c, r_{bb}'	$V_{CB}=10\text{V}$ $I_E=-1.0\text{mA}$ $f=30\text{MHz}$			25	ps

2SC2216 (3DG2216)

