

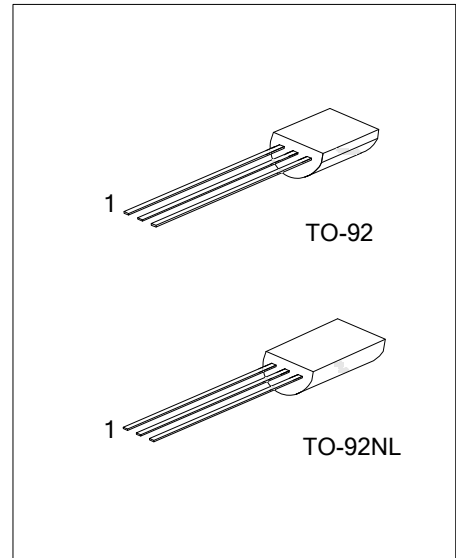

2SC2235

NPN SILICON TRANSISTOR

AUDIO POWER AMPLIFIER
 APPLICATIONS DRIVER STAGE
 AMPLIFIER APPLICATIONS



■ FEATURES

* Complimentary to UTC 2SA965

■ ORDERING INFORMATION

Ordering Number		Package	Pin Assignment			Packing
Lead Free	Halogen Free		1	2	3	
2SC2235L-x-T92-B	2SC2235G-x-T92-B	TO-92	E	C	B	Tape Box
2SC2235L-x-T92-K	2SC2235G-x-T92-K	TO-92	E	C	B	Bulk
2SC2235L-x-T9N-B	2SC2235G-x-T9N-B	TO-92NL	E	C	B	Tape Box
2SC2235L-x-T9N-K	2SC2235G-x-T9N-K	TO-92NL	E	C	B	Bulk

Note: Pin Assignment: E: Emitter C: Collector B: Base

<p>2SC2235L-x-T92-B</p>	<p>(1) Packing Type (2) Package Type (3) Rank (4) Green Package</p>	<p>(1) B: Tape Box, K: Bulk (2) T92: TO-92, T9N: TO-92NL (3) x: refer to Classification of h_{FE} (4) L: Lead Free, G: Halogen Free and Lead Free</p>
-------------------------	--	---

■ MARKING

TO-92	TO-92NL

■ ABSOLUTE MAXIMUM RATING ($T_A=25^{\circ}\text{C}$, unless otherwise specified)

PARAMETER	SYMBOL	RATINGS	UNIT
Collector-Base Voltage	V_{CB0}	120	V
Collector-Emitter Voltage	V_{CE0}	120	V
Emitter-Base Voltage	V_{EBO}	5	V
Collector Current	I_C	800	mA
Emitter Current	I_E	-800	mA
Collector Power Dissipation	P_C	600	mW
Junction Temperature	T_J	150	$^{\circ}\text{C}$
Storage Temperature	T_{STG}	-55 ~ +150	$^{\circ}\text{C}$

Note: Absolute maximum ratings are those values beyond which the device could be permanently damaged. Absolute maximum ratings are stress ratings only and functional device operation is not implied.

■ ELECTRICAL CHARACTERISTICS ($T_A=25^{\circ}\text{C}$, unless otherwise specified)

PARAMETER	SYMBOL	TEST CONDITIONS	MIN	TYP	MAX	UNIT
Collector-Emitter Breakdown Voltage	$V_{B_{CE0}}$	$I_C = 10\text{mA}, I_B = 0$	120			V
Emitter-Base Breakdown Voltage	$V_{B_{EBO}}$	$I_E = 1\text{mA}, I_C = 0$	5			V
Collector Cut-off Current	I_{CBO}	$V_{CB} = 120\text{V}, I_E = 0$			100	nA
Emitter Cut-off Current	I_{EBO}	$V_{EB} = 5\text{V}, I_C = 0$			100	nA
DC Current Gain	h_{FE}	$V_{CE} = 5\text{V}, I_C = 100\text{mA}$	80		240	
Collector-Emitter Saturation Voltage	$V_{CE(SAT)}$	$I_C = 500\text{mA}, I_B = 50\text{mA}$			1.0	V
Base-Emitter Voltage	V_{BE}	$V_{CE} = 5\text{V}, I_C = 500\text{mA}$			1.0	V
Transition Frequency	f_T	$V_{CE} = 5\text{V}, I_C = 100\text{mA}$		120		MHz
Collector Output Capacitance	C_{ob}	$V_{CB} = 10\text{V}, I_E = 0, f = 1\text{MHz}$			30	pF

■ CLASSIFICATION OF h_{FE}

RANK	Y	O
RANGE	120-240	80-160

■ TYPICAL CHARACTERISTICS

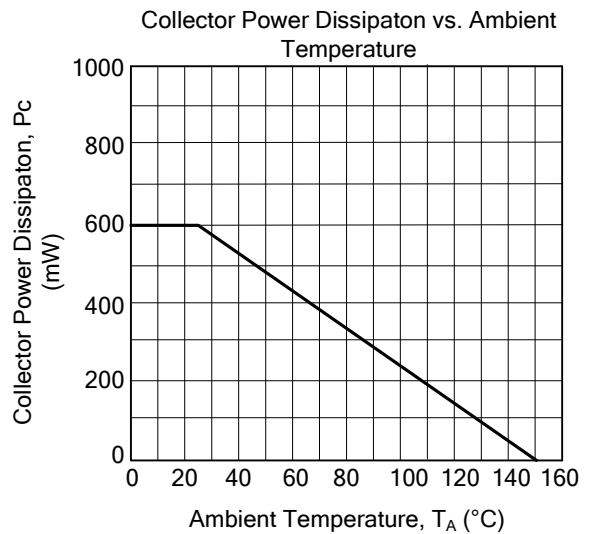
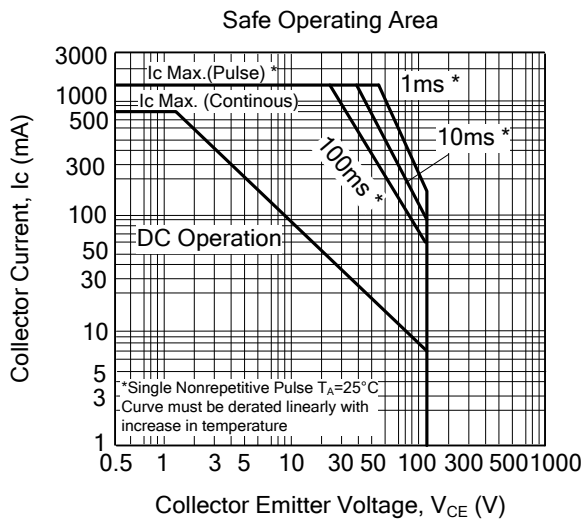
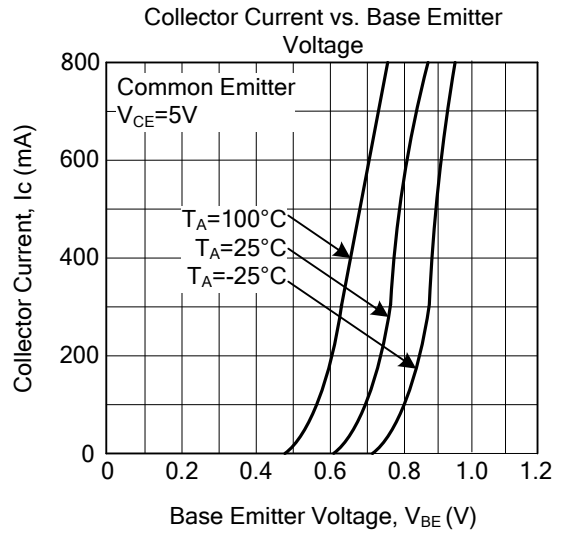
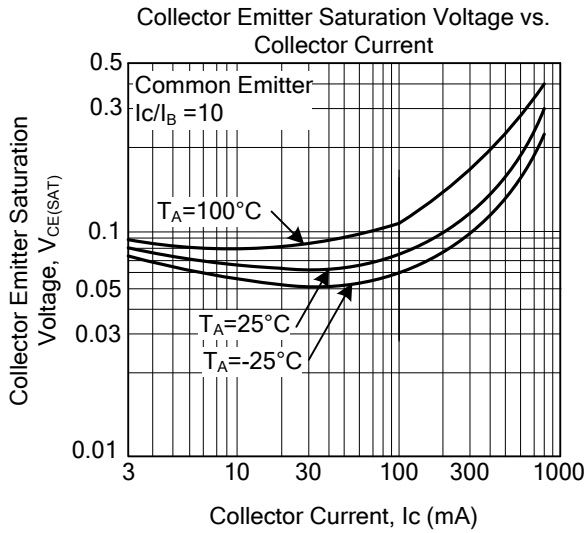
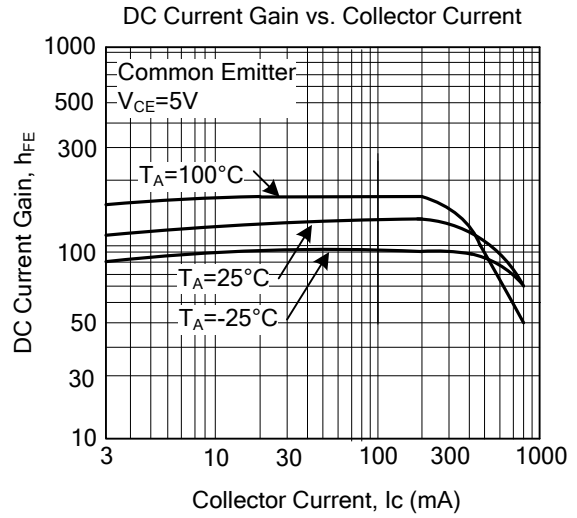
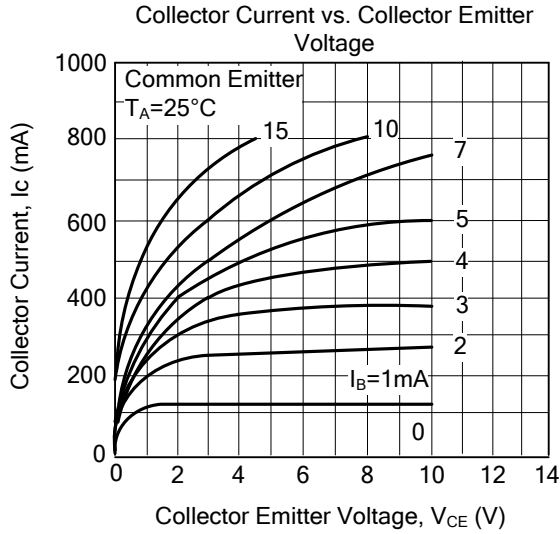

UTC assumes no responsibility for equipment failures that result from using products at values that exceed, even momentarily, rated values (such as maximum ratings, operating condition ranges, or other parameters) listed in products specifications of any and all UTC products described or contained herein. UTC products are not designed for use in life support appliances, devices or systems where malfunction of these products can be reasonably expected to result in personal injury. Reproduction in whole or in part is prohibited without the prior written consent of the copyright owner. The information presented in this document does not form part of any quotation or contract, is believed to be accurate and reliable and may be changed without notice.