

### NPN EPITAXIAL SILICON TRANSISTOR

AM/FM IF AMPLIFIER, LOCAL OSCILATOR  
OF FM/VHF TUNER

- High Current Gain Bandwidth  
Product  $f_T=600\text{MHz}$

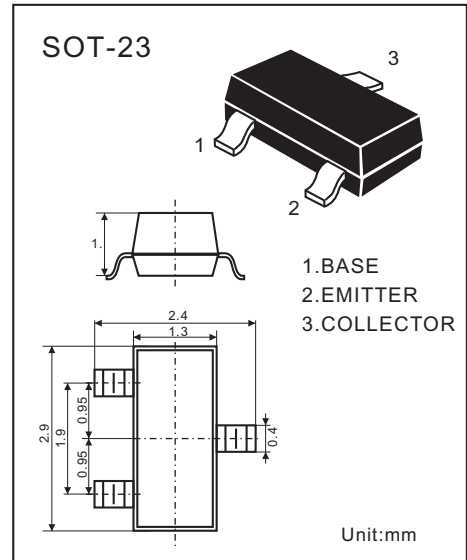

#### ABSOLUTE MAXIMUM RATINGS

( $T_a=25^\circ\text{C}$ )

Characteristic	Symbol	Rating	Unit
Collector-Base Voltage	$V_{CB0}$	30	V
Collector-Emitter Voltage	$V_{CEO}$	15	V
Emitter-Base Voltage	$V_{EBO}$	5	V
Collector Current	$I_C$	50	mA
Collector Dissipation $T_a=25^\circ\text{C}^*$	$P_D$	225	mW
Junction Temperature	$T_j$	150	$^\circ\text{C}$
Storage Temperature	$T_{stg}$	-55~150	$^\circ\text{C}$

#### Electrical Characteristics

( $T_a=25^\circ\text{C}$ )

Parameter	Symbol	MIN.	TYP.	MAX.	Unit	Condition
Collector-Base Breakdown Voltage	$BV_{CB0}$	30			V	$I_C=100\mu\text{A}$ $I_E=0$
Collector-Emitter Breakdown Voltage#	$BV_{CEO}$	15			V	$I_C=1\text{mA}$ $I_B=0$
Emitter-Base Breakdown Voltage	$BV_{EBO}$	5			V	$I_E=100\mu\text{A}$ $I_C=0$
Collector-Base Cutoff Current	$I_{CBO}$			50	nA	$V_{CB}=12\text{V}$ , $V_E=0$
Emitter-Base Cutoff Current	$I_{EBO}$			50	nA	$V_{CB}=3\text{V}$ , $I_C=0$
DC Current Gain	$H_{FE}$	28	100	300		$V_{CB}=5\text{V}$ , $I_C=1\text{mA}$
Collector-Emitter Saturation Voltage	$V_{CE(sat)}$			0.5	V	$I_C=10\text{mA}$ , $I_B=1\text{mA}$
Collector-Base Capacitance	$C_{ob}$		1.3	1.7	PF	$V_{CB}=10\text{V}$ , $I_E=10$ , $f=1\text{MHz}$
Collector-Gain-Bandwidth Product	$f_T$	700	1100		MHZ	$V_{CE}=5\text{V}$ , $I_C=5\text{mA}$

\*Total Device Dissipation:FR=1X0.75X0.062 in Board Derate  $25^\circ\text{C}$

#Pulse Test: Pulse Width 300uS Duty cycle 2%

DEVICE MARKING:

2SC2715=J8