

Silicon NPN Power Transistors

2SC3365

DESCRIPTION

With TO-3PN package

·High voltage ,high speed

APPLICATIONS

·For high speed and high power switching applications

PINNING

PIN	DESCRIPTION
1	Base
2	Collector;connected to mounting base
3	Emitter

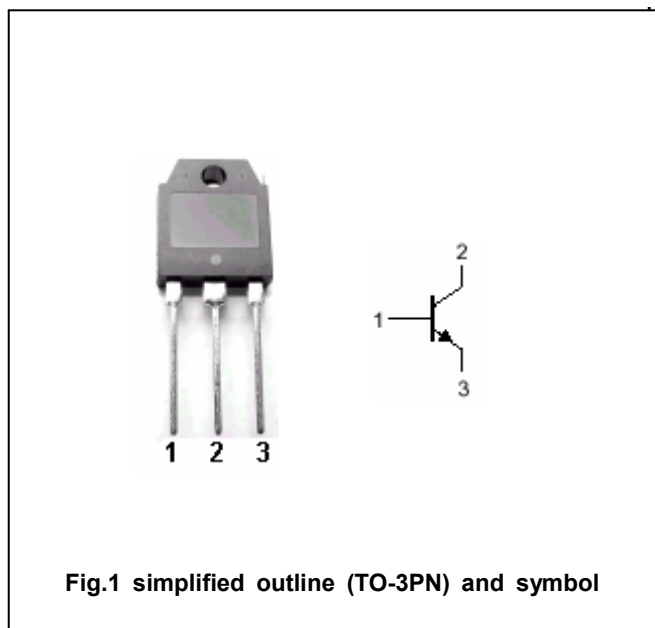

Fig.1 simplified outline (TO-3PN) and symbol

Absolute maximum ratings(Ta=25°C)

SYMBOL	PARAMETER	CONDITIONS	VALUE	UNIT
V _{CBO}	Collector-base voltage	Open emitter	500	V
V _{CEO}	Collector-emitter voltage	Open base	400	V
V _{EBO}	Emitter-base voltage	Open collector	10	V
I _C	Collector current		10	A
I _{CM}	Collector current-peak		20	A
I _B	Base current		5	A
P _C	Collector power dissipation	T _C =25°C	80	W
T _j	Junction temperature		150	°C
T _{stg}	Storage temperature		-55~150	°C

Silicon NPN Power Transistors

2SC3365

CHARACTERISTICS

T_j=25°C unless otherwise specified

SYMBOL	PARAMETER	CONDITIONS	MIN	TYP.	MAX	UNIT
V _{CEO(SUS)}	Collector-emitter sustaining voltage	I _C =0.2A ; R _{BE} =∞, L=100mH	400			V
V _{(BR)EBO}	Emitter-base breakdown voltage	I _E =10mA ; I _C =0	10			V
V _{CEsat}	Collector-emitter saturation voltage	I _C =5A ; I _B =1A			1.0	V
V _{BEsat}	Base-emitter saturation voltage	I _C =5A ; I _B =1A			1.5	V
I _{CBO}	Collector cut-off current	V _{CB} =400V ; I _E =0			50	μA
I _{CEO}	Collector cut-off current	V _{CE} =350V ; R _{BE} =∞			50	μA
h _{FE-1}	DC current gain	I _C =5A ; V _{CE} =5V	12			
h _{FE-2}	DC current gain	I _C =10A ; V _{CE} =5V	5			

Switching times resistive load

t _{on}	Turn-on time	I _C =10A ; I _{B1} =-I _{B2} =2A V _{CC} ≈150V			1.0	μs
t _s	Storage time				2.5	μs
t _f	Fall time				1.0	μs

Silicon NPN Power Transistors

2SC3365

PACKAGE OUTLINE

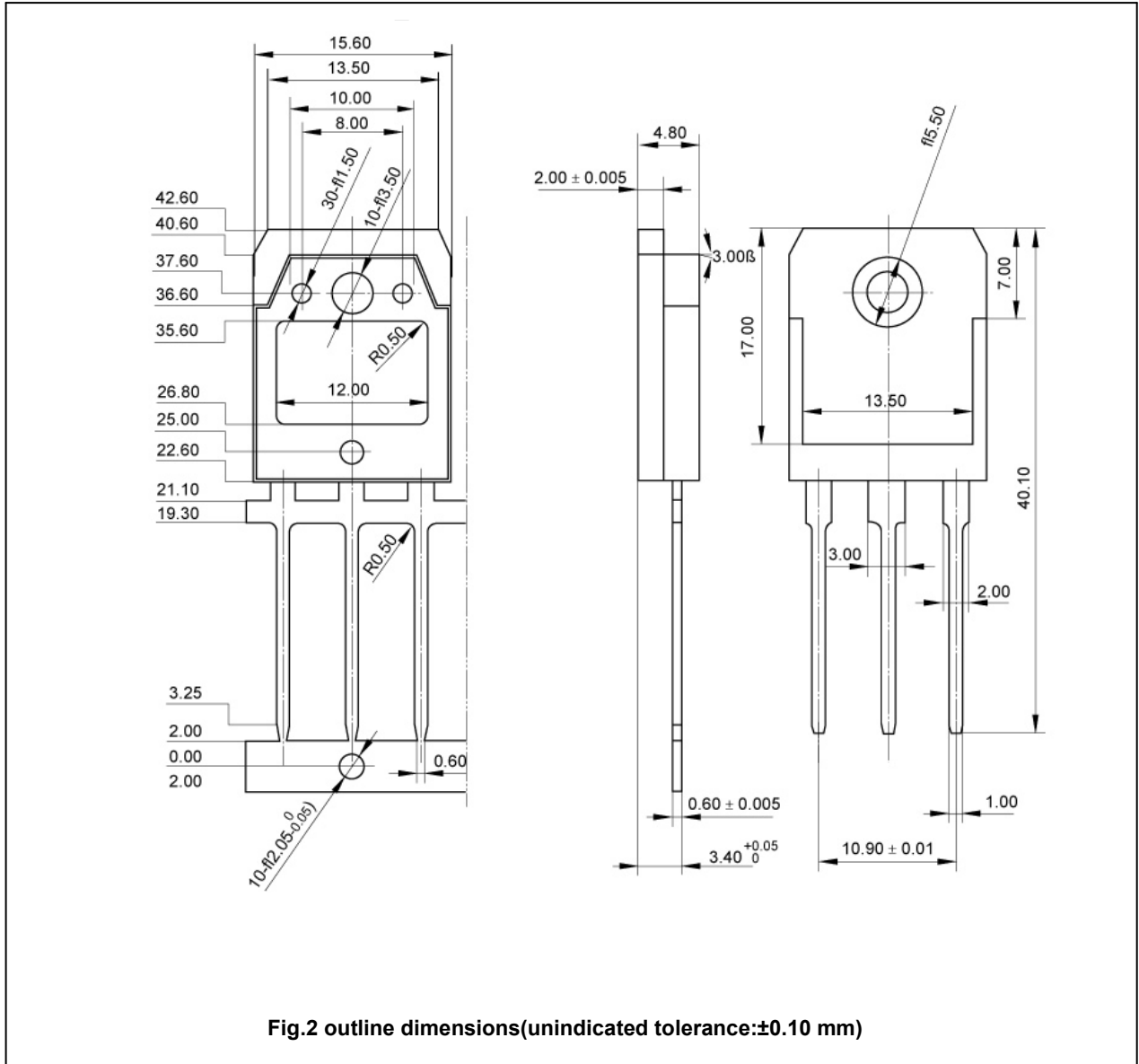

Fig.2 outline dimensions(unindicated tolerance:±0.10 mm)

Silicon NPN Power Transistors

2SC3365

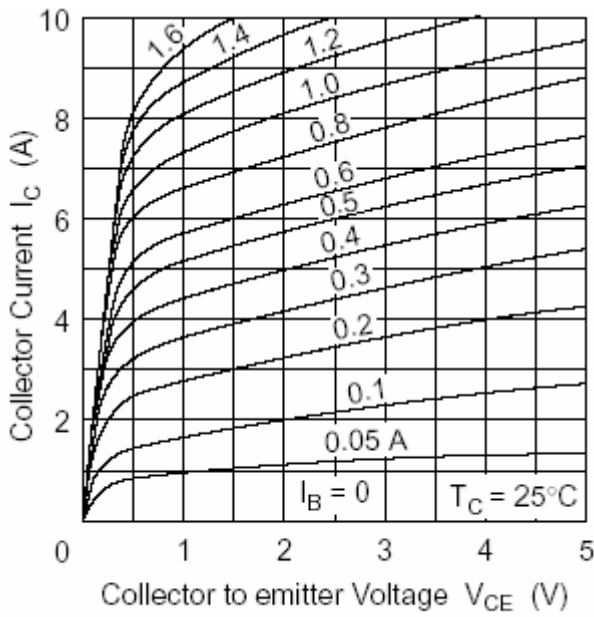

Fig.3 Static Characteristic

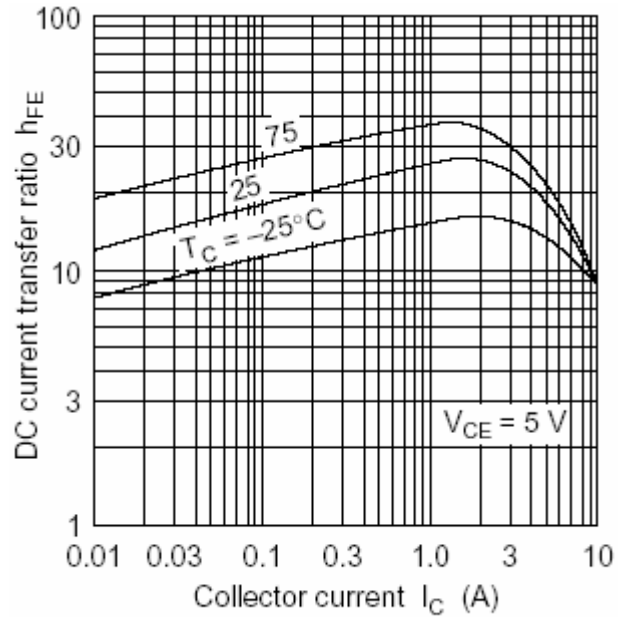

Fig.4 DC current Gain

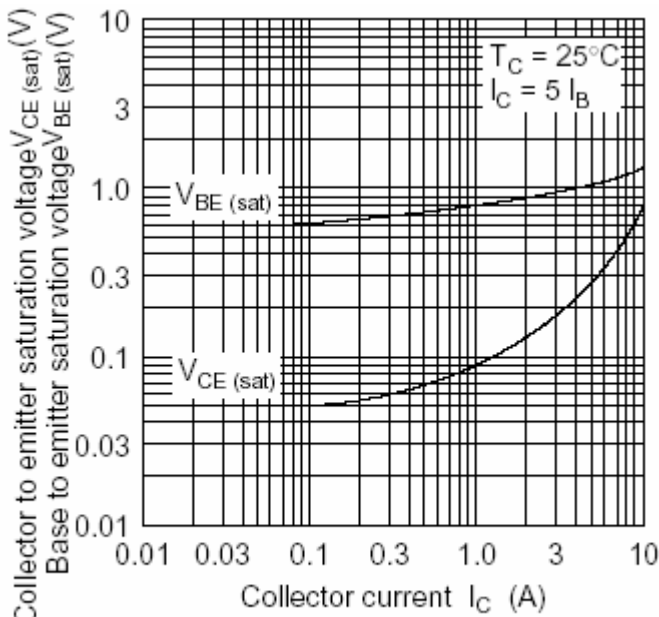

Fig.5 Base-Emitter Saturation Voltage
Collector-Emmitter Saturation Voltage

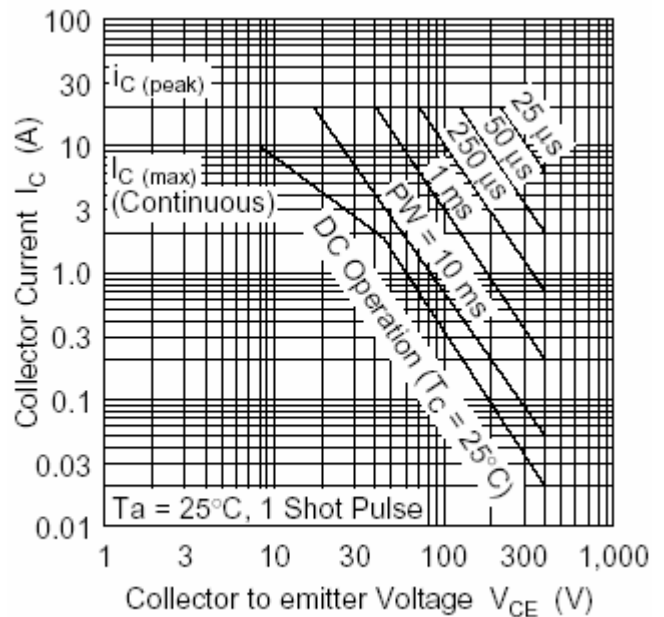

Fig.6 Safe Operating Area