

## Silicon NPN Power Transistors

## 2SC3619

## DESCRIPTION

- With TO-126 package
- High voltage
- Small collector output capacitance

## APPLICATIONS

- High voltage switching and amplifier
- Color TV horizontal driver applications
- Color TV chroma output applications

## PINNING

PIN	DESCRIPTION
1	Emitter
2	Collector;connected to mounting base
3	Base

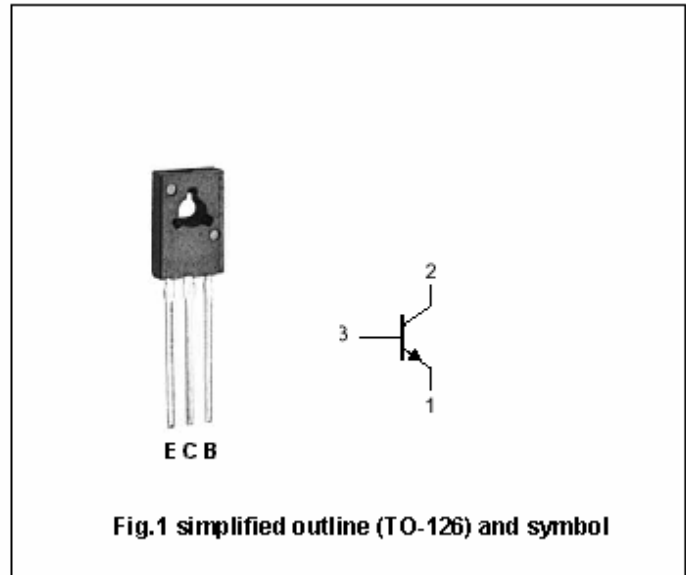
Absolute maximum ratings( $T_a=25^\circ\text{C}$ )

SYMBOL	PARAMETER	CONDITIONS	VALUE	UNIT
$V_{CBO}$	Collector-base voltage	Open emitter	300	V
$V_{CEO}$	Collector- emitter voltage	Open base	300	V
$V_{EBO}$	Emitter-base voltage	Open collector	7	V
$I_C$	Collector current		0.1	A
$I_B$	Base current		50	mA
$P_C$	Collector power dissipation	$T_C=25^\circ\text{C}$	1.5	W
$T_j$	Junction temperature		150	$^\circ\text{C}$
$T_{stg}$	Storage temperature		$-55^\circ\text{C}+150^\circ\text{C}$	$^\circ\text{C}$

## Silicon NPN Power Transistors

## 2SC3619

## CHARACTERISTICS

T<sub>j</sub>=25°C unless otherwise specified

SYMBOL	PARAMETER	CONDITIONS	MIN	TYP.	MAX	UNIT
I <sub>CB0</sub>	Collector cutoff current	V <sub>CB</sub> =240V; I <sub>E</sub> =0			0.1	μA
I <sub>EB0</sub>	Emitter cutoff current	V <sub>EB</sub> =7V; I <sub>C</sub> =0			0.1	μA
V <sub>CEsat</sub>	Collector-emitter saturation voltage	I <sub>C</sub> =10mA ; I <sub>B</sub> =1mA			1	V
V <sub>BEsat</sub>	Base-emitter saturation voltage	I <sub>C</sub> =10mA ; I <sub>B</sub> =1mA			1	V
h <sub>FE-1</sub>	DC current gain	I <sub>C</sub> =4mA ; V <sub>CE</sub> =10V	20			
h <sub>FE-2</sub>	DC current gain	I <sub>C</sub> =20mA ; V <sub>CE</sub> =10V	30		200	
C <sub>Ob</sub>	Output capacitance	I <sub>E</sub> =0; V <sub>CB</sub> =20V; f=1MHz		3		pF
f <sub>T</sub>	Transition frequency	I <sub>C</sub> =20mA ; V <sub>CE</sub> =10V,	50			MHz

Silicon NPN Power Transistors

2SC3619

PACKAGE OUTLINE

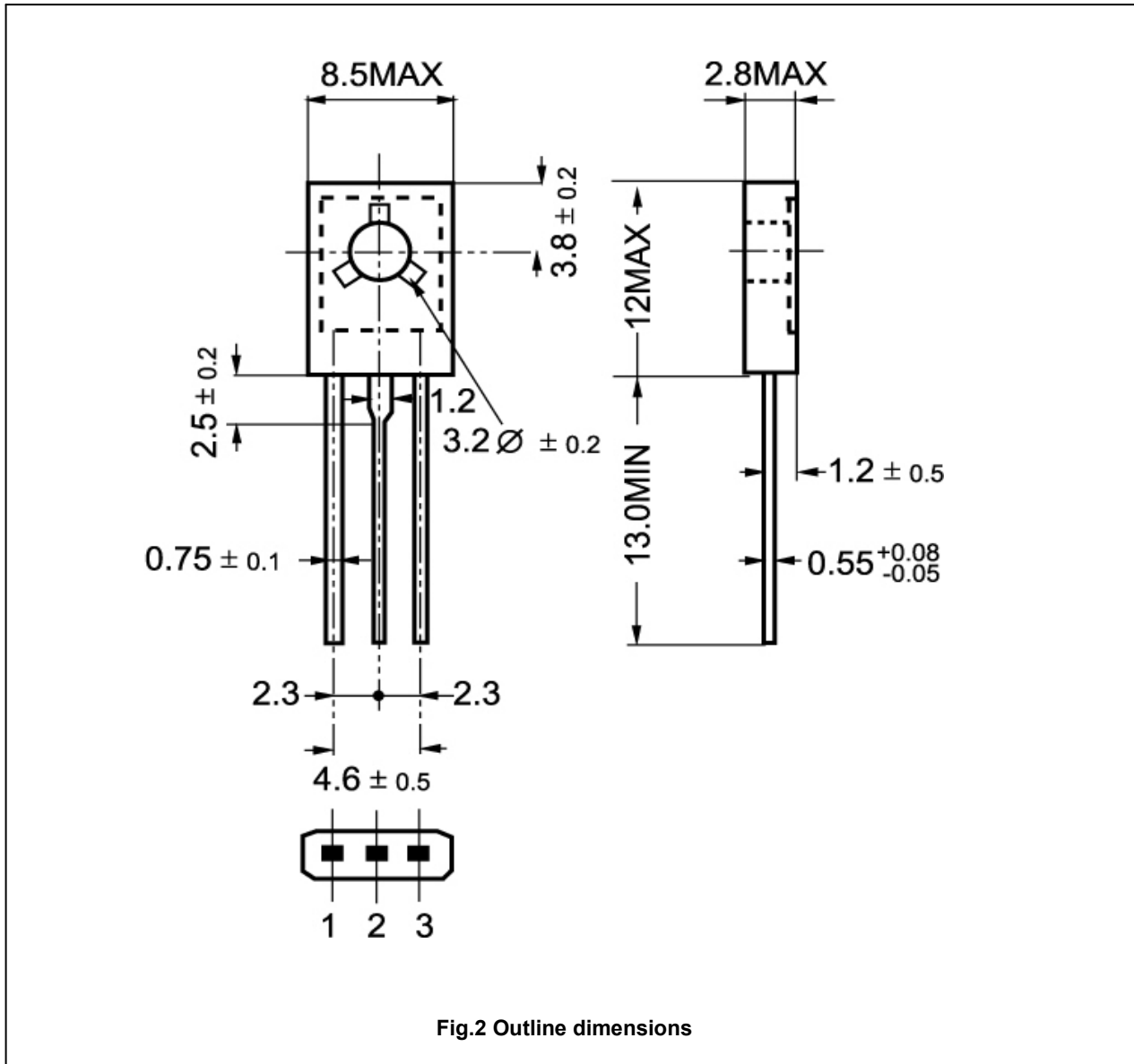

Silicon NPN Power Transistors

2SC3619

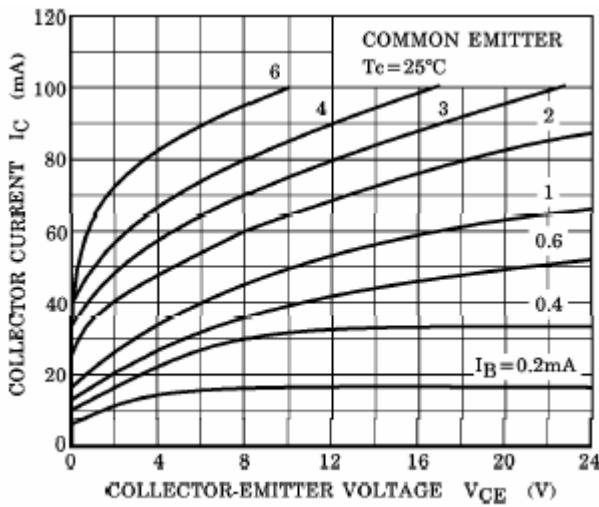

Fig.3 Static Characteristic

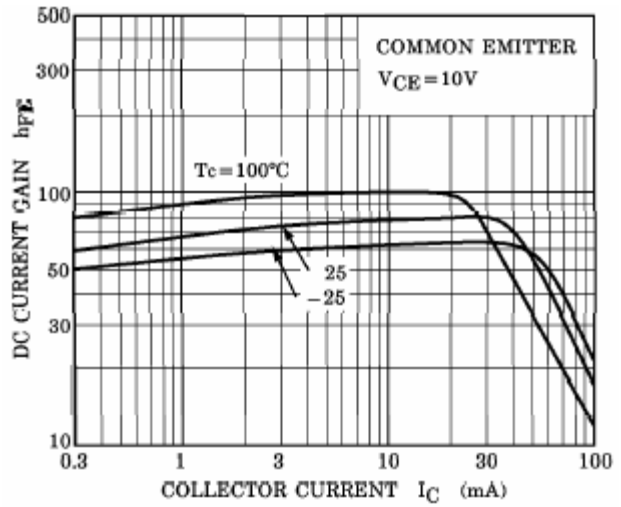

Fig.4 DC current Gain

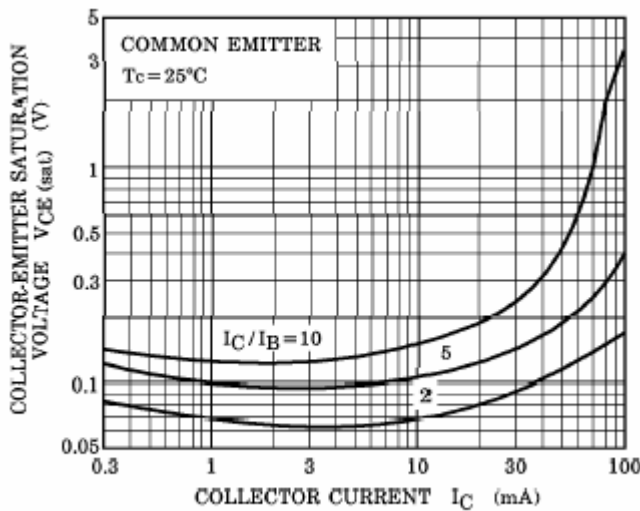

Fig.5 Collector-Emitter Saturation Voltage

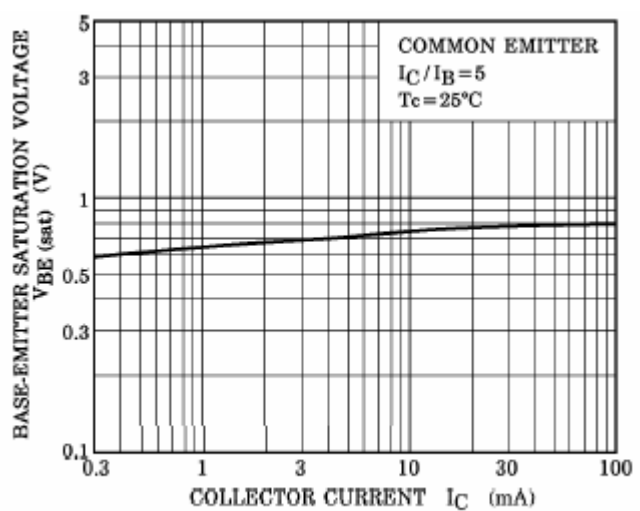

Fig.6 Base-Emitter Saturation Voltage

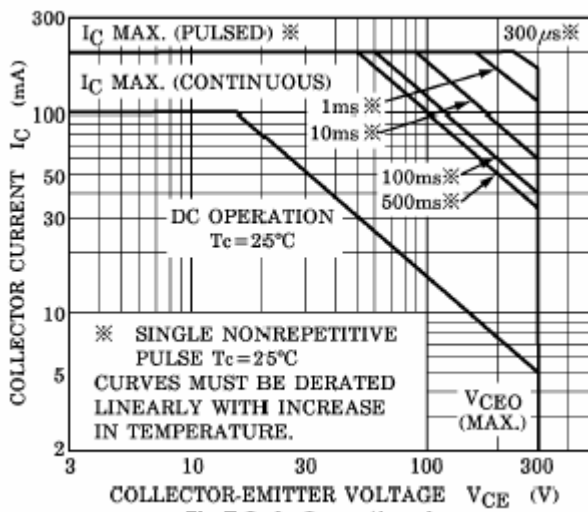

Fig.7 Safe Operating Area