

## High-Voltage Switching Applications

## 2SC3647

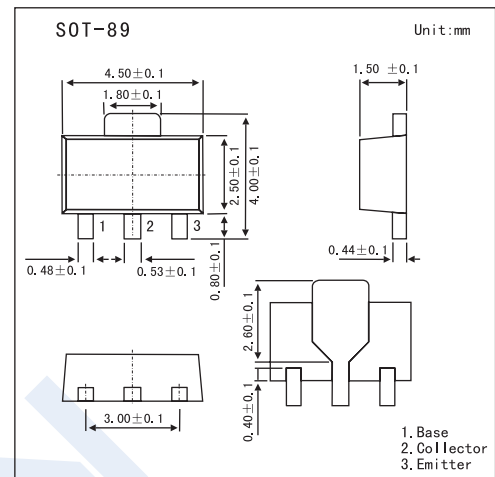

### ■ Features

- Adoption of FBET, MBIT Processes
- High Breakdown Voltage and Large Current Capacity

### ■ Absolute Maximum Ratings $T_a = 25^\circ\text{C}$

Parameter	Symbol	Rating	Unit
Collector-Base Voltage	$V_{CB0}$	120	V
Collector-Emitter Voltage	$V_{CE0}$	100	V
Emitter-Base Voltage	$V_{EB0}$	6	V
Collector Current	$I_C$	2	A
Collector Current (Pulse)	$I_{CP}$	3	A
Collector Power Dissipation	$P_C$	500	mW
	$P_{C^*}$	1.5	W
Junction temperature	$T_j$	150	$^\circ\text{C}$
Storage temperature Range	$T_{stg}$	-55 to +150	$^\circ\text{C}$

\* Mounted on ceramic board (250 mm<sup>2</sup> x 0.8 mm)

### ■ Electrical Characteristics $T_a = 25^\circ\text{C}$

Parameter	Symbol	Test conditions	Min	Typ	Max	Unit
Collector Cut-off Current	$I_{CBO}$	$V_{CB} = 100V, I_E = 0$			100	nA
Emitter Cut-off Current	$I_{EBO}$	$V_{EB} = 4V, I_C = 0$			100	nA
Collector-Base Breakdown Voltage	$V_{(BR)CBO}$	$I_C = 10\mu A, I_E = 0$	120			V
Collector-Emitter Breakdown Voltage	$V_{(BR)CEO}$	$I_C = 1mA, R_{BE} = \infty$	100			V
Emitter-Base Breakdown Voltage	$V_{(BR)EBO}$	$I_E = 10\mu A, I_C = 0$	6			V
DC Current Gain	$h_{FE}$	$V_{CE} = 5V, I_C = 100mA$	100		400	
Collector-Emitter Saturation Voltage	$V_{CE(sat)}$	$I_C = 1A, I_B = 100mA$		0.22	0.6	V
Base-Emitter Saturation Voltage	$V_{BE(sat)}$	$I_C = 1A, I_B = 100mA$		0.85	1.2	V
Gain-Bandwidth Product	$f_T$	$V_{CE} = 10V, I_C = 100mA$		120		MHz
Collector Output Capacitance	$C_{ob}$	$V_{CB} = 10V, I_E = 0, f = 1MHz$		25		pF
Turn-On Time	$t_{on}$	See Test Circuit.		80		ns
Storage Time	$t_{stg}$			750		
Fall Time	$t_f$			40		

# 2SC3647

## Test Circuit

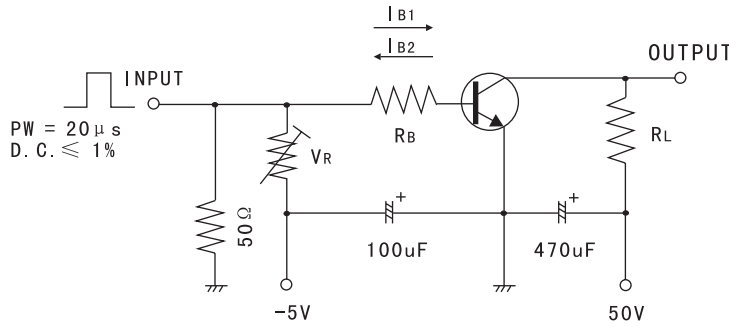

$10I_{B1} = -10I_{B2} = I_C = 0.7A$   
 (For PNP, the polarity is reversed.)

## hFE Classification

Marking	CC		
Rank	R	S	T
hFE	100 ~ 200	140 ~ 280	200 ~ 400

## Electrical Characteristics Curves

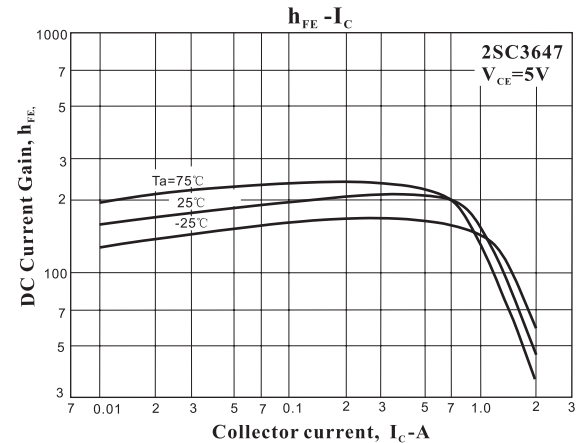
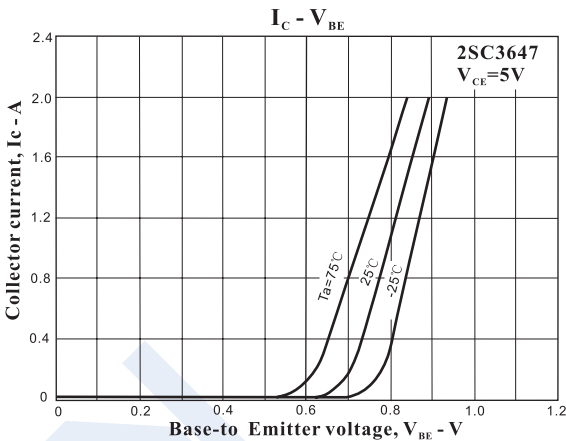
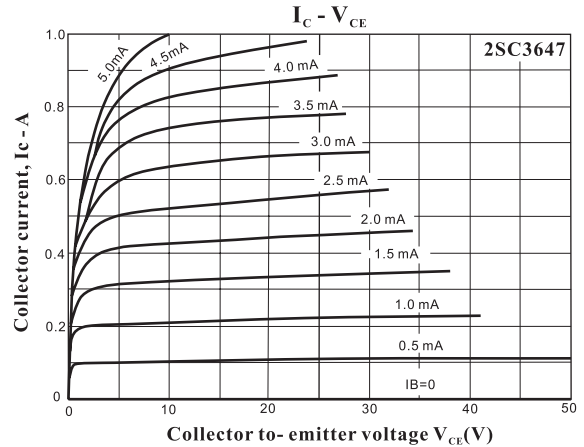
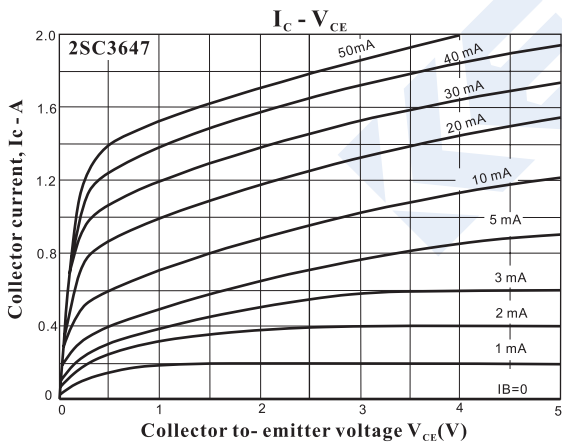

# 2SC3647

