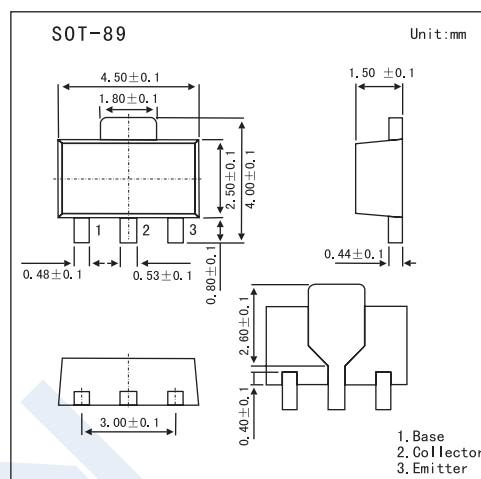

High-Voltage Switching Applications

2SC3648

■ Features

- Adoption of FBET, MBIT Processes
- High Breakdown Voltage and Large Current Capacity
- Fast Switching Speed

■ Absolute Maximum Ratings $T_a = 25^\circ\text{C}$

Parameter	Symbol	Rating	Unit
Collector-Base Voltage	V_{CB0}	180	V
Collector-Emitter Voltage	V_{CE0}	160	V
Emitter-Base Voltage	V_{EBO}	6	V
Collector Current	I_C	0.7	A
Collector Current (Pulse)	I_{CP}	1.5	A
Collector Power Dissipation	P_C	500	mW
	P_{C^*}	1.3	W
Junction temperature	T_j	150	$^\circ\text{C}$
Storage temperature Range	T_{stg}	-55 to +150	$^\circ\text{C}$

* Mounted on ceramic board (250 mm² x 0.8 mm)

■ Electrical Characteristics $T_a = 25^\circ\text{C}$

Parameter	Symbol	Testconditions	Min	Typ	Max	Unit
Collector Cut-off Current	I_{CBO}	$V_{CB} = 120\text{V}, I_E = 0$			0.1	μA
Emitter Cut-off Current	I_{EBO}	$V_{EB} = 4\text{V}, I_C = 0$			0.1	μA
Collector-Base Breakdown Voltage	$V_{(BR)CBO}$	$I_C = 10\mu\text{A}, I_E = 0$	180			V
Collector-Emitter Breakdown Voltage	$V_{(BR)CEO}$	$I_C = 1\text{mA}, R_{BE} = \infty$	160			V
Emitter-Base Breakdown Voltage	$V_{(BR)EBO}$	$I_E = 10\mu\text{A}, I_C = 0$	6			V
DC Current Gain	h_{FE}	$V_{CE} = 5\text{V}, I_C = 100\text{mA}$	100		400	
Collector-Emitter Saturation Voltage	$V_{CE(sat)}$	$I_C = 250\text{mA}, I_B = 25\text{mA}$		0.2	0.5	V
Base-Emitter Saturation Voltage	$V_{BE(sat)}$	$I_C = 250\text{mA}, I_B = 25\text{mA}$		0.85	1.2	V
Gain-Bandwidth Product	f_T	$V_{CE} = 10\text{V}, I_C = 50\text{mA}$		120		MHz
Collector Output Capacitance	C_{ob}	$V_{CB} = 10\text{V}, I_E = 0, f = 1\text{MHz}$		11		pF
Turn-On Time	t_{on}	See Test Circuit.		60		ns
Storage Time	t_{stg}			900		
Fall Time	t_f			60		

2SC3648

Test Circuit

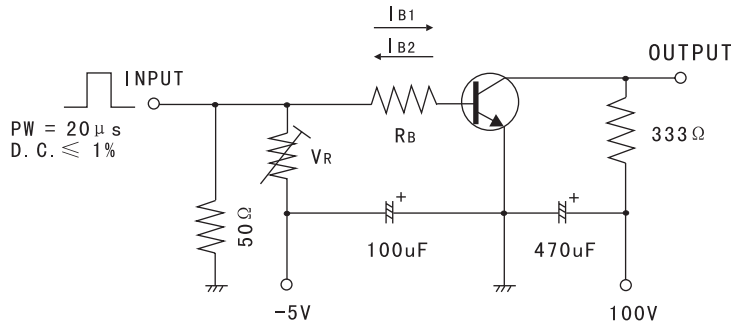

$20I_{B1} = -20I_{B2} = I_C = 300\text{mA}$
 (For PNP, the polarity is reversed.)

hFE Classification

Marking	CD		
Rank	R	S	T
hFE	100 ~ 200	140 ~ 280	200 ~ 400

Electrical Characteristics Curves

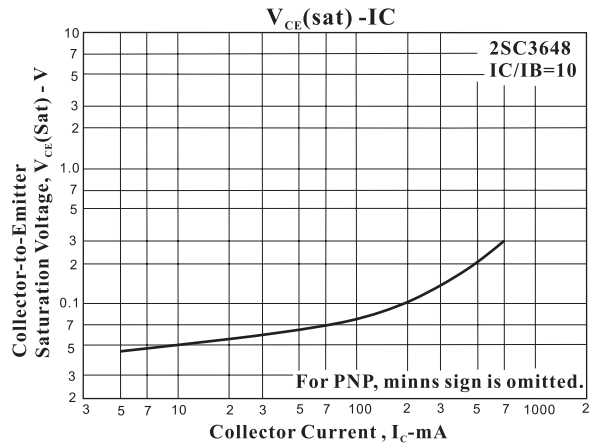
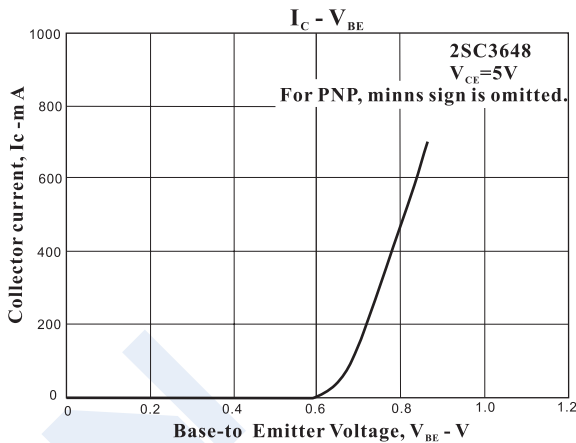
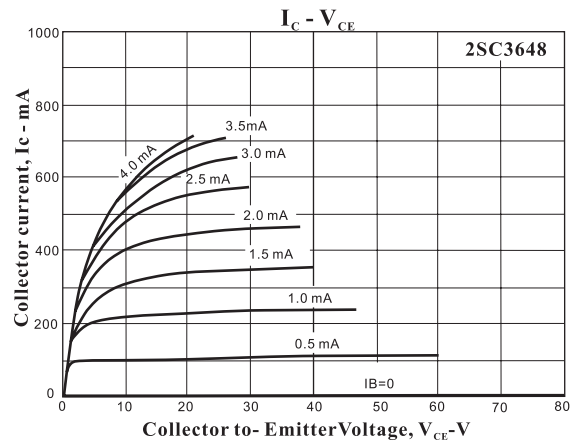
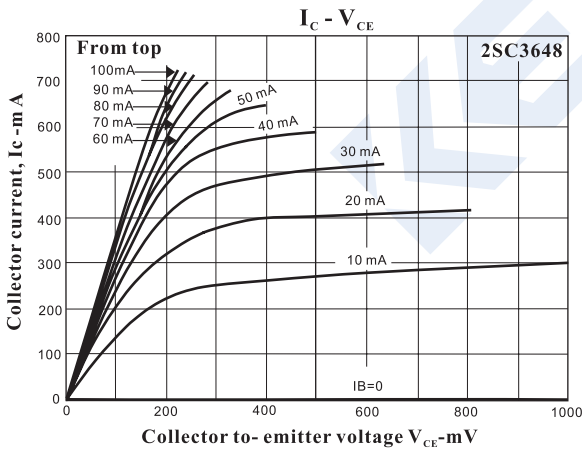

2SC3648

