

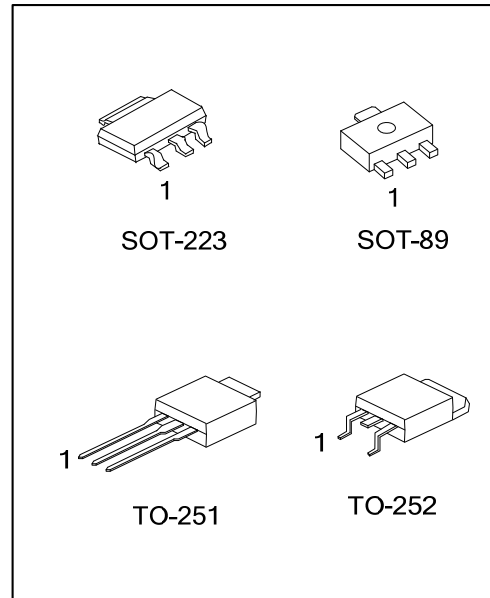

2SC3669

NPN EPITAXIAL SILICON TRANSISTOR

POWER AMPLIFIER
APPLICATIONS POWER
SWITCHING APPLICATIONS



FEATURES

- * Low saturation voltage
 $V_{CE(SAT)}=0.5V$ (Max.)
- * High speed switching time: $T_{STG}=1.0\mu s$ (Typ.)

ORDERING INFORMATION

Ordering Number		Package	Pin Assignment			Packing
Lead Free	Halogen Free		1	2	3	
-	2SC3669G-x-AA3-R	SOT-223	B	C	E	Tape Reel
-	2SC3669G-x-AB3-R	SOT-89	B	C	E	Tape Reel
2SC3669L-x-TM3-T	2SC3669G-x-TM3-T	TO-251	B	C	E	Tube
2SC3669L-x-TN3-R	2SC3669G-x-TN3-R	TO-252	B	C	E	Tape Reel

Note: Pin Assignment: B: Base C: Collector E: Emitter

<p>2SC3669G-x-AA3-R</p>	<p>(1) R: Tape Reel, T: Tube (2) AA3: SOT-223, AB3: SOT-89, TM3: TO-251 TN3: TO-252 (3) x: refer to Classification of h_{FE1} (4) G: Halogen Free and Lead Free, L: Lead Free</p>
-------------------------	--

MARKING

SOT-223	SOT-89	TO-251 / TO-252

■ PIN ABSOLUTE MAXIMUM RATING (T_A=25°C, unless otherwise specified)

PARAMETER		SYMBOL	RATINGS	UNIT
Collector-Base Voltage		V _{CBO}	80	V
Collector-Emitter Voltage		V _{CEO}	80	V
Emitter-Base Voltage		V _{EBO}	5	V
Collector Current		I _C	2	A
Base Current		I _B	1	A
Collector Power Dissipation	SOT-223/SOT-89	P _C	0.5	W
	TO-251/TO-252		1	W
Junction Temperature		T _J	150	°C
Storage Temperature		T _{STG}	-55 ~ +150	°C

Notes: 1. Absolute maximum ratings are those values beyond which the device could be permanently damaged. Absolute maximum ratings are stress ratings only and functional device operation is not implied.
 2. The device is guaranteed to meet performance specification within 0°C~70°C operating temperature range and assured by design from -20°C~85°C.

■ ELECTRICAL CHARACTERISTICS (T_A=25°C, unless otherwise specified)

PARAMETER		SYMBOL	TEST CONDITIONS	MIN	TYP	MAX	UNIT
Collector Emitter Breakdown Voltage		V _{(BR)CEO}	I _C = 10mA, I _B = 0	80			V
Collector Cut-Off Current		I _{CBO}	V _{CB} =80V, I _E = 0			1.0	μA
Emitter Cut-Off Current		I _{EBO}	V _{EB} = 5V, I _C =0			1.0	μA
DC Current Gain		h _{FE1}	V _{CE} =2V, I _C =0.5A	70		240	
		h _{FE2}	V _{CE} =2V, I _C =1.5A	40			
Collector-Emitter Saturation Voltage		V _{CE(SAT)}	I _C =1A, I _B =0.05A		0.15	0.5	V
Base- Emitter Saturation Voltage		V _{BE(SAT)}	I _C =1A, I _B =0.05A		0.9	1.2	V
Transition Frequency		f _T	V _{CE} =2V, I _C =0.5A		100		MHz
Collector Output Capacitance		C _{ob}	V _{CB} = 10V, I _E = 0, f=1MHz		30		pF
Switching Time	Turn-on Time	t _{ON}			0.2		μs
	Storage Time	T _{STG}			1.0		μs
	Fall Time	t _f		I _{B1} = -I _{B2} =0.05A DUTY CYCLE ≤ 1%		0.2	

■ CLASSIFICATION OF h_{FE1}

RANK	O	Y
RANGE	70~140	120~240

■ TYPICAL CHARACTERISTICS

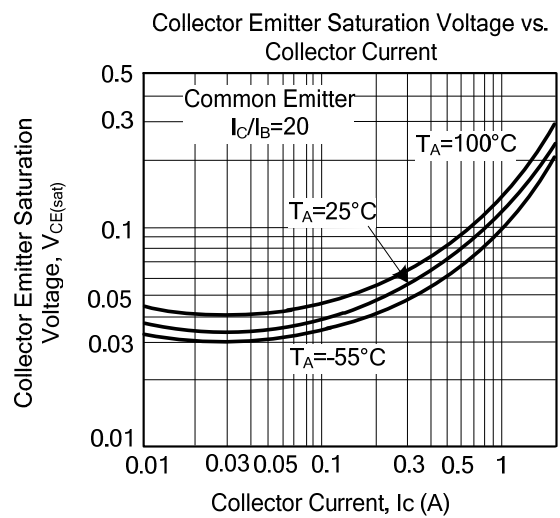
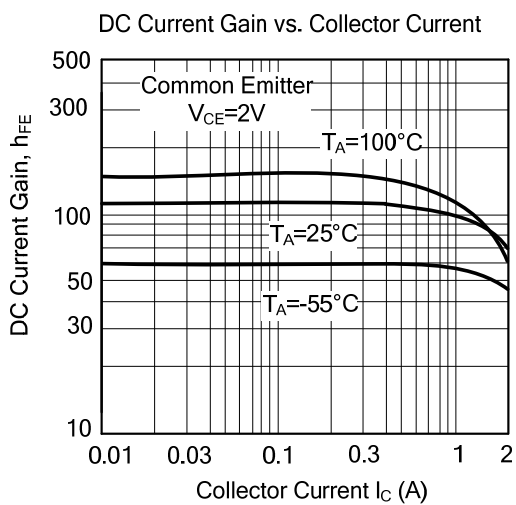
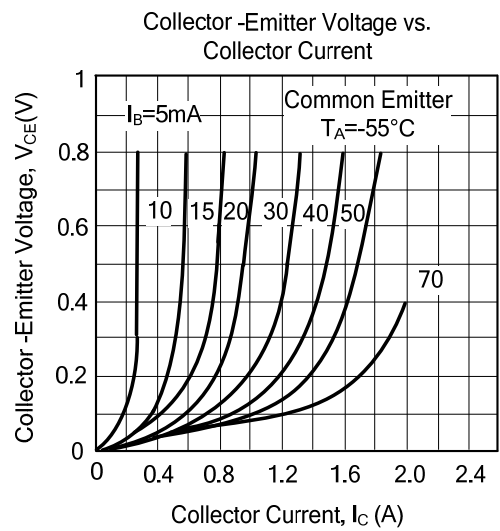
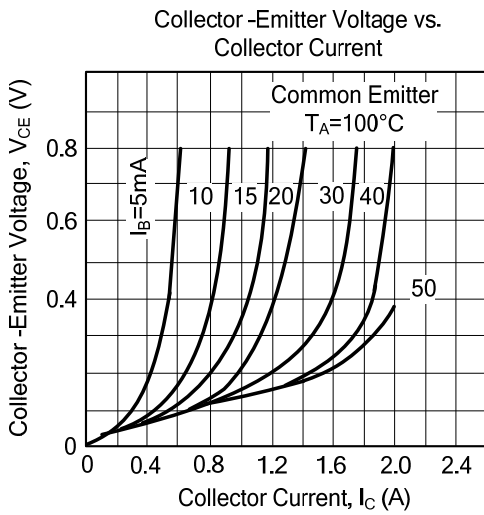
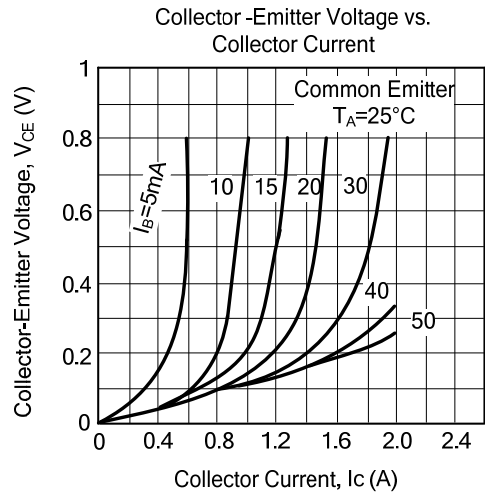
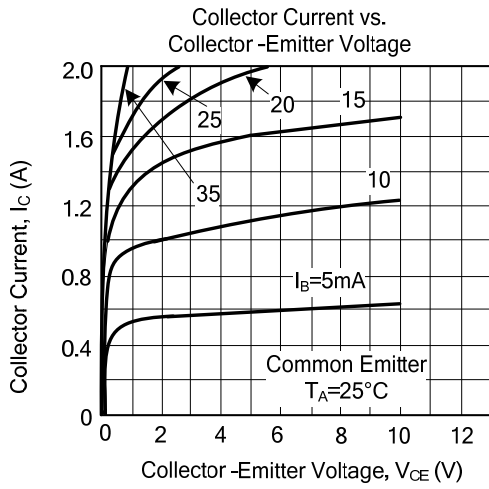

■ TYPICAL CHARACTERISTICS (Cont.)

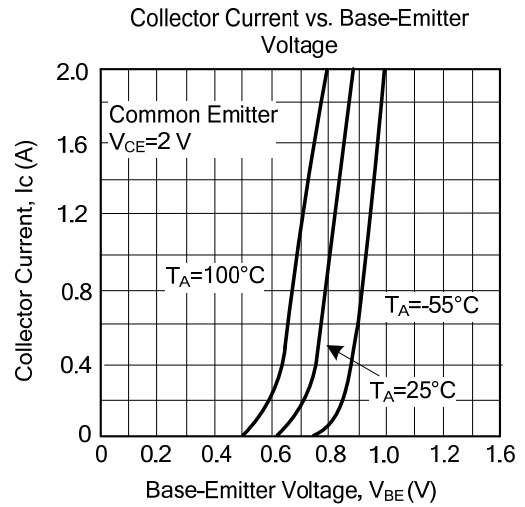
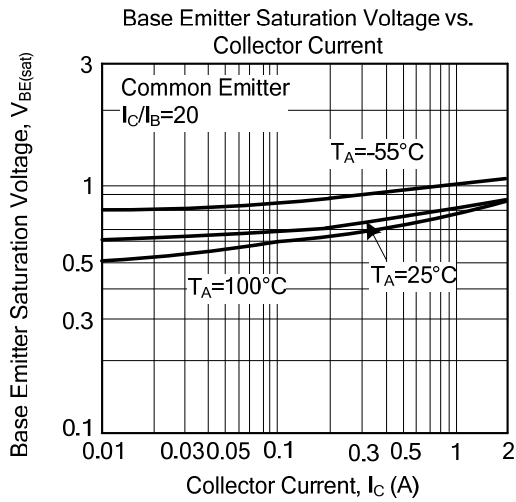

UTC assumes no responsibility for equipment failures that result from using products at values that exceed, even momentarily, rated values (such as maximum ratings, operating condition ranges, or other parameters) listed in products specifications of any and all UTC products described or contained herein. UTC products are not designed for use in life support appliances, devices or systems where malfunction of these products can be reasonably expected to result in personal injury. Reproduction in whole or in part is prohibited without the prior written consent of the copyright owner. The information presented in this document does not form part of any quotation or contract, is believed to be accurate and reliable and may be changed without notice.