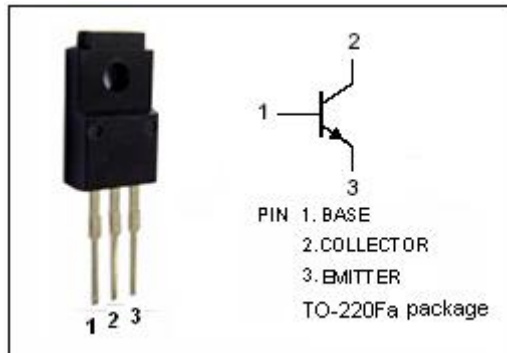

isc Silicon NPN Power Transistor
2SC3694
DESCRIPTION

- Low Collector Saturation Voltage
: $V_{CE(sat)} = 0.5V(\text{Max}) @ I_C = 12A$
- Collector-Emitter Sustaining Voltage-
: $V_{CEO(SUS)} = 60V (\text{Min})$
- Minimum Lot-to-Lot variations for robust device performance and reliable operation

APPLICATIONS

- Designed for high speed and power switching applications

ABSOLUTE MAXIMUM RATINGS ($T_a = 25^\circ\text{C}$)

SYMBOL	PARAMETER	VALUE	UNIT
V_{CBO}	Collector-Base Voltage	100	V
V_{CEO}	Collector-Emitter Voltage	60	V
V_{EBO}	Emitter-Base Voltage	7	V
I_C	Collector Current-Continuous	15	A
I_{CM}	Collector Current-Peak	30	A
I_B	Base Current-Continuous	7.5	A
P_C	Collector Power Dissipation @ $T_c = 25^\circ\text{C}$	30	W
	Collector Power Dissipation @ $T_a = 25^\circ\text{C}$	2	
T_J	Junction Temperature	150	$^\circ\text{C}$
T_{stg}	Storage Temperature Range	-55~150	$^\circ\text{C}$

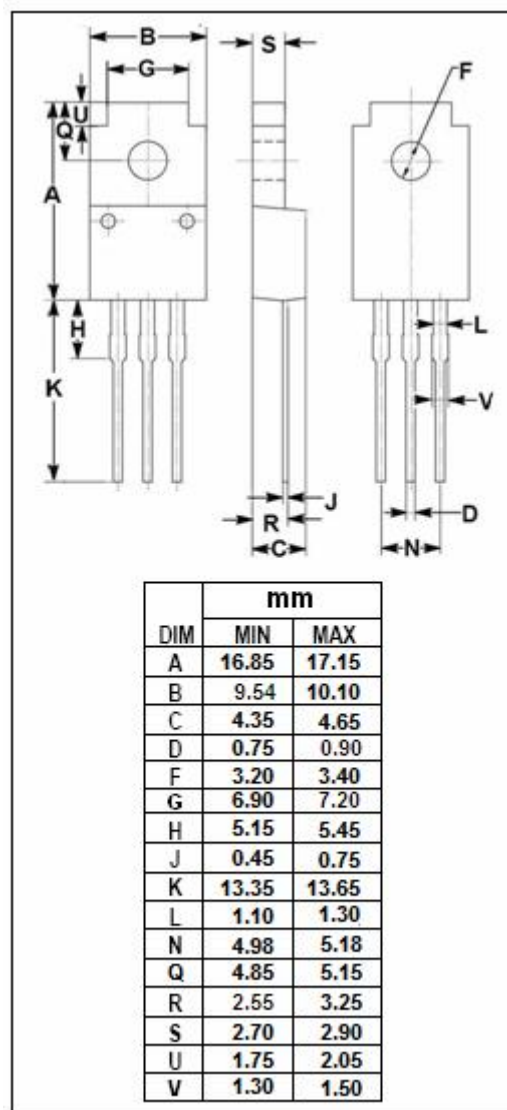

isc Silicon NPN Power Transistor
2SC3694
ELECTRICAL CHARACTERISTICS
T_c=25°C unless otherwise specified

SYMBOL	PARAMETER	CONDITIONS	MIN	TYP.	MAX	UNIT
V _{CE0(SUS)}	Collector-Emitter Sustaining Voltage	I _C =50mA; I _B = 0	60			V
V _{CE(sat)-1}	Collector-Emitter Saturation Voltage	I _C = 8A; I _B = 0.4A			0.3	V
V _{CE(sat)-2}	Collector-Emitter Saturation Voltage	I _C = 12A; I _B = 0.6A			0.5	V
V _{BE(sat)-1}	Base-Emitter Saturation Voltage	I _C = 8A; I _B = 0.4A			1.2	V
V _{BE(sat)-2}	Base-Emitter Saturation Voltage	I _C = 12A; I _B = 0.6A			1.5	V
I _{CBO}	Collector Cutoff Current	V _{CB} = 60V; I _E = 0			10	μA
I _{CEX}	Collector Cutoff Current	V _{CE} = 60V; V _{BE} = -1.5V V _{CE} = 60V; V _{BE} = -1.5V; T _a =125°C			10 1.0	μA mA
I _{EBO}	Emitter Cutoff Current	V _{EB} = 5V; I _C = 0			10	μA
h _{FE-1}	DC Current Gain	I _C = 1.5A; V _{CE} = 2V	100			
h _{FE-2}	DC Current Gain	I _C = 3A; V _{CE} = 2V	100	200	400	
h _{FE-3}	DC Current Gain	I _C = 8A; V _{CE} = 2V	60			
f _T	Current-Gain—Bandwidth Product	I _C =1.5A; V _{CE} = 10V		120		MHz
C _{OB}	Output Capacitance	I _E =0; V _{CB} = 10V; f _{test} = 1.0MHz		180		pF
Switching times						
t _{on}	Turn-on Time	I _C = 8A; I _{B1} = -I _{B2} = 0.4A; R _L = 6.3 Ω; V _{CC} ≈ 50V			0.3	μs
t _{stg}	Storage Time				1.5	μs
t _f	Fall Time				0.3	μs

◆ h_{FE-2} classifications

M	L	K
100-200	150-300	200-400

Notice:

ISC reserves the rights to make changes of the content herein the datasheet at any time without notification. The information contained herein is presented only as a guide for the applications of our products.

ISC products are intended for usage in general electronic equipment. The products are not designed for use in equipment which require specialized quality and/or reliability, or in equipment which could have applications in hazardous environments, aerospace industry, or medical field. Please contact us if you intend our products to be used in these special applications.

ISC makes no warranty or guarantee regarding the suitability of its products for any particular purpose, nor does ISC assume any liability arising from the application or use of any products, and specifically disclaims any and all liability, including without limitation special, consequential or incidental damages.