

NPN Epitaxial Planar Silicon Transistor

2SC4003

FEATURES

- High h_{FE} $h_{FE}=60$ to 200.
- Low $V_{CE(sat)}=0.6V$.

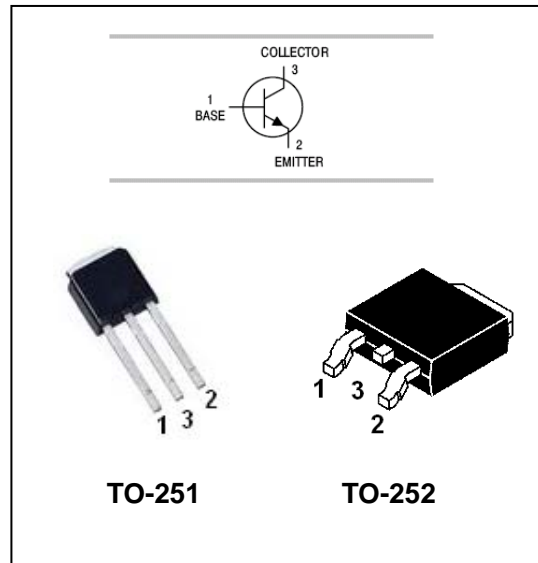

MAXIMUM RATING operating temperature range applies unless otherwise specified

Symbol	Parameter	Value	Units
V_{CBO}	Collector-Base Volage	400	V
V_{CEO}	Collector-Emitter Voltage	400	V
V_{EBO}	Emitter-Base Voltage	5	V
I_C	Collector Current(DC)	0.2	A
P_C	Collector Power Dissipation	1	W
T_j, T_{stg}	Junction and Storage temperature range	-55 to +150	°C

NPN Epitaxial Planar Silicon Transistor

2SC4003

ELECTRICAL CHARACTERISTICS @ $T_a=25^\circ\text{C}$ unless otherwise specified

Parameter	Symbol	Test conditions	MIN	TYP	MAX	UNIT
Collector-base breakdown voltage	V_{CB0}	$I_C=10\mu\text{A}, I_E=0$	400			V
Collector-emitter breakdown voltage	V_{CEO}	$I_C=1\text{mA}, I_B=0$	400			V
Emitter-base breakdown voltage	V_{EBO}	$I_E=10\mu\text{A}, I_C=0$	5			V
Collector cut-off current	I_{CBO}	$V_{CB}=300\text{V}, I_E=0$			0.1	μA
Emitter cut-off current	I_{EBO}	$V_{EBO}=4\text{V}, I_C=0$			0.1	μA
DC current gain	h_{FE}	$V_{CE}=10\text{V}, I_C=50\text{mA}$	60		200	
Collector-emitter saturation voltage	$V_{CE(sat)}$	$I_C=50\text{mA}, I_B=5\text{mA}$			0.6	V
Base-emitter saturation voltage	$V_{BE(sat)}$	$I_C=50\text{mA}, I_B=5\text{mA}$			1	V
Transition frequency	f_T	$V_{CE}=30\text{V}, I_C=10\text{mA}$		70		MHz

CLASSIFICATION OF $h_{FE(1)}$

Rank	D	E
Range	60-120	100-200

TYPICAL CHARACTERISTICS @ $T_a=25^\circ\text{C}$ unless otherwise specified

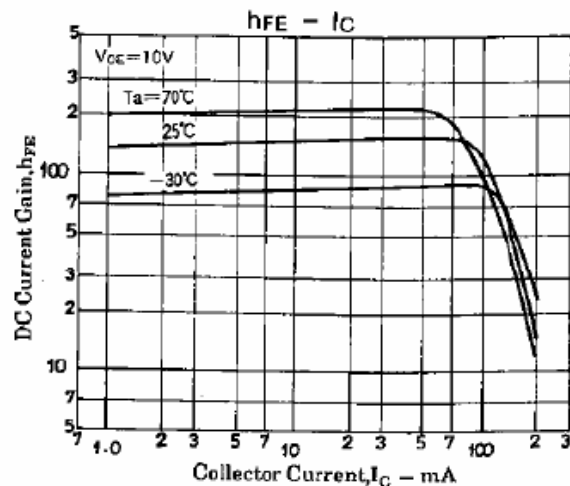
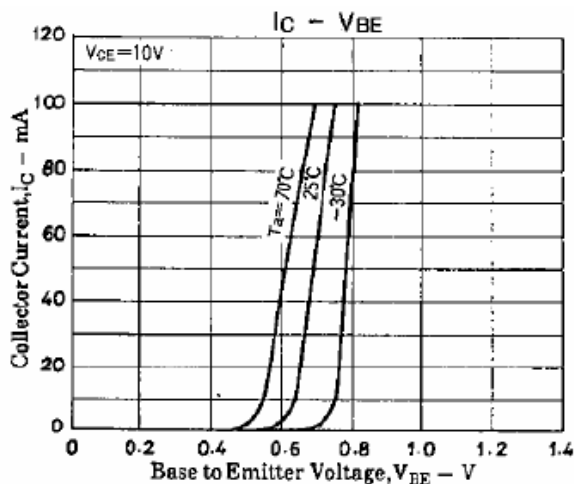

NPN Epitaxial Planar Silicon Transistor

2SC4003

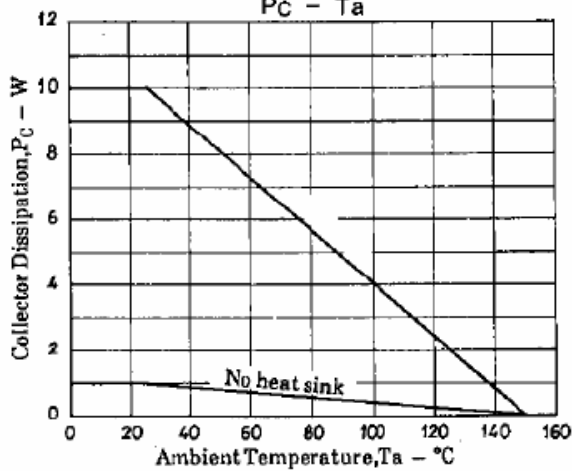
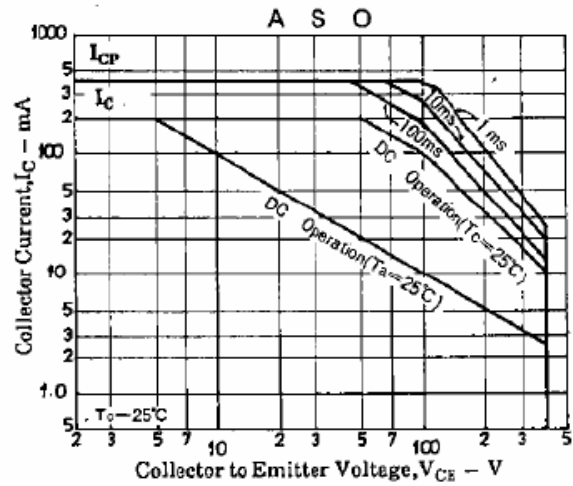
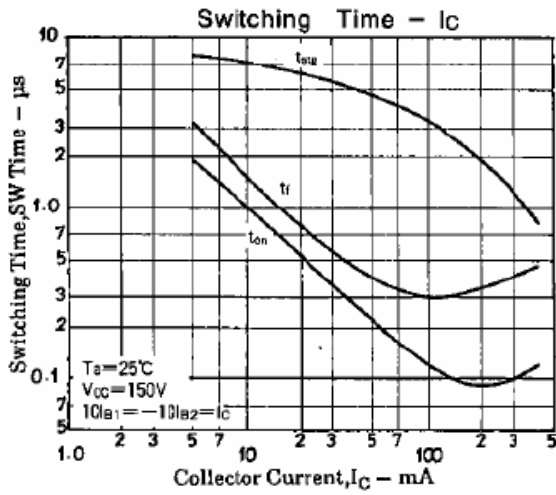
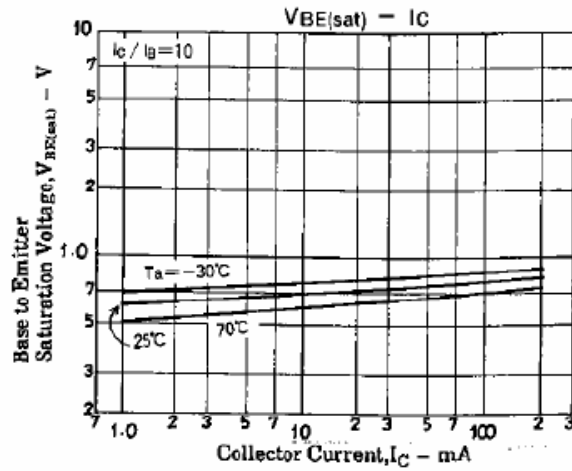
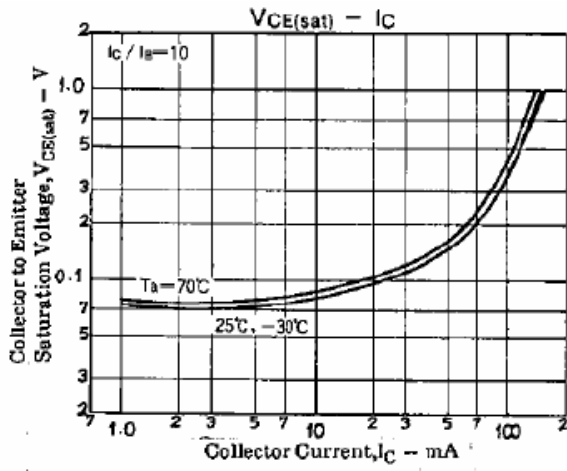

NPN Epitaxial Planar Silicon Transistor

2SC4003

PACKAGE OUTLINE

Plastic surface mounted package

TO-251

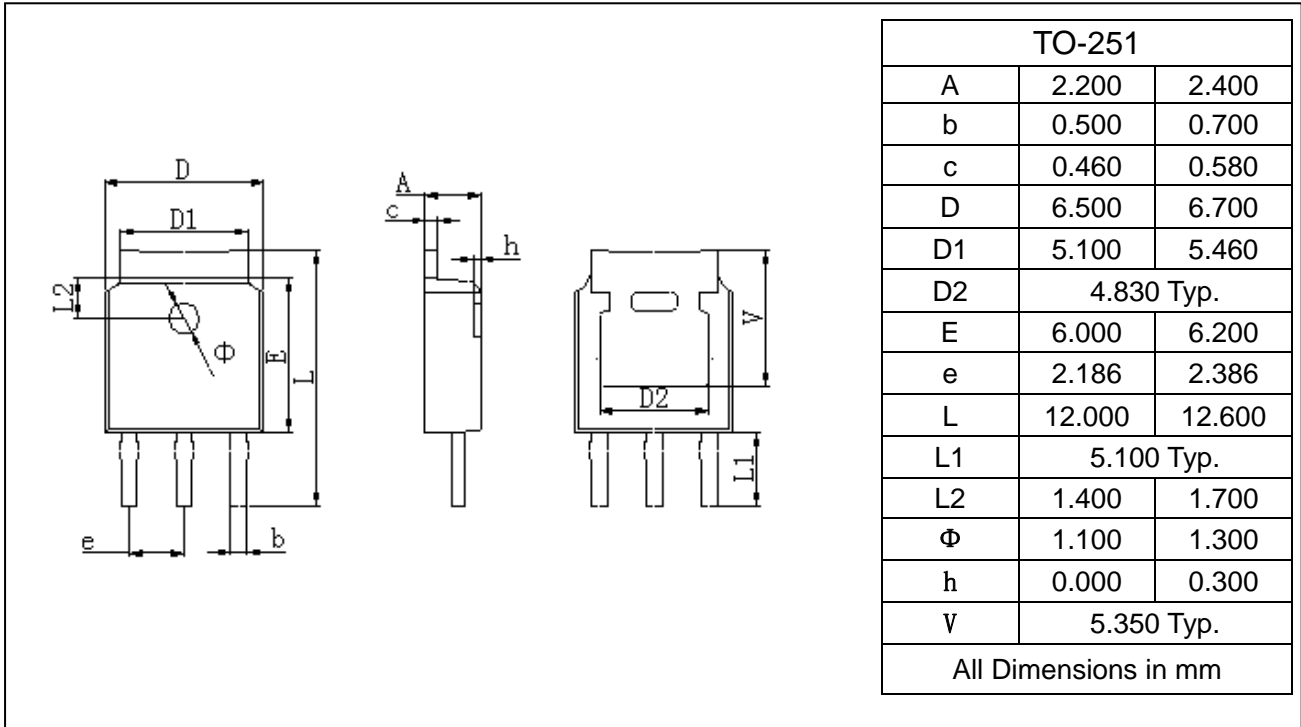

PACKAGE OUTLINE

Plastic surface mounted package

TO-252

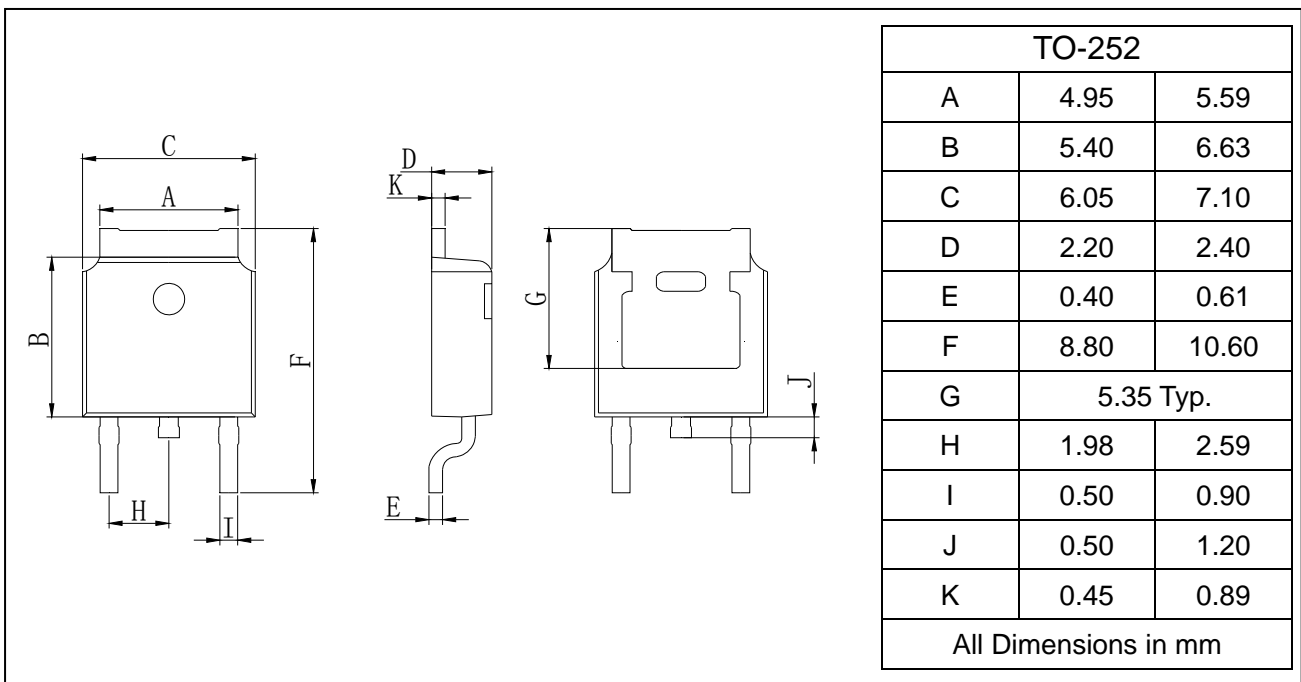

NPN Epitaxial Planar Silicon Transistor

2SC4003

SOLDERING FOOTPRINT

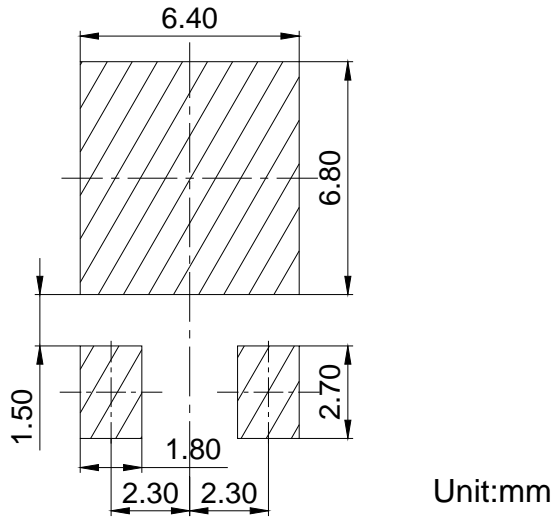

PACKAGE INFORMATION

Device	Package	Shipping
2SC4003	TO-251/252	80PCS/Tube
	TO-252	2500PCS/Tape&Reel