

## Silicon NPN Power Transistors

2SC4233

## DESCRIPTION

With TO-220C package

- High breakdown voltage
- Switching power transistor

## PINNING

PIN	DESCRIPTION
1	Base
2	Collector;connected to mounting base
3	Emitter

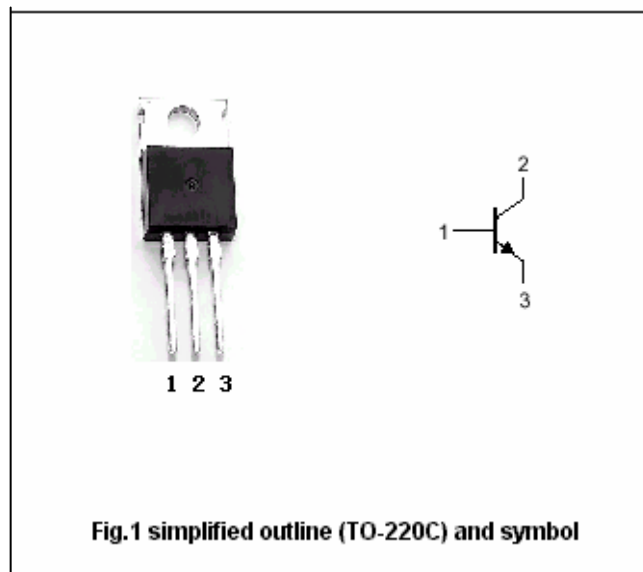

Fig.1 simplified outline (TO-220C) and symbol

## Absolute maximum ratings(Ta=25°C)

SYMBOL	PARAMETER	CONDITIONS	VALUE	UNIT
$V_{CBO}$	Collector-base voltage	Open emitter	1200	V
$V_{CEO}$	Collector-emitter voltage	Open base	800	V
$V_{EBO}$	Emitter-base voltage	Open collector	7	V
$I_C$	Collector current		3	A
$I_{CM}$	Collector current-peak		6	A
$I_B$	Base current		1	A
$I_{BM}$	Base current-peak		2	A
$P_C$	Collector dissipation	$T_C=25^\circ\text{C}$	60	W
$T_j$	Junction temperature		150	°C
$T_{stg}$	Storage temperature		-55~150	°C

## THERMAL CHARACTERISTICS

SYMBOL	PARAMETER	MAX	UNIT
$R_{th\ j-c}$	Thermal resistance junction case	2.08	°C/W

## Silicon NPN Power Transistors

## 2SC4233

## CHARACTERISTICS

T<sub>j</sub>=25°C unless otherwise specified

SYMBOL	PARAMETER	CONDITIONS	MIN	TYP.	MAX	UNIT
V <sub>CEO(SUS)</sub>	Collector-emitter sustaining voltage	I <sub>C</sub> =0.1A; R <sub>BE</sub> =∞	800			V
V <sub>CE(sat)</sub>	Collector-emitter saturation voltage	I <sub>C</sub> =1.5A; I <sub>B</sub> =0.3A			1.0	V
V <sub>BE(sat)</sub>	Base-emitter saturation voltage	I <sub>C</sub> =1.5A; I <sub>B</sub> =0.3A			1.5	V
I <sub>CBO</sub>	Collector cut-off current	At rated voltage			100	μA
I <sub>CEO</sub>	Collector cut-off current					
I <sub>EBO</sub>	Emitter cut-off current	At rated voltage			100	μA
h <sub>FE-1</sub>	DC current gain	I <sub>C</sub> =1.5A; V <sub>CE</sub> =5V	8			
h <sub>FE-2</sub>	DC current gain	I <sub>C</sub> =1mA; V <sub>CE</sub> =5V	7			
f <sub>T</sub>	Transition frequency	I <sub>C</sub> =0.3A; V <sub>CE</sub> =10V		8		MHz

## Switching times

t <sub>on</sub>	Turn-on time	V <sub>BB2</sub> =4V; I <sub>C</sub> =1.5A I <sub>B1</sub> =0.3A; I <sub>B2</sub> =0.6A R <sub>L</sub> =170Ω			0.5	μs
t <sub>stg</sub>	Storage time				3.5	μs
t <sub>f</sub>	Fall time				0.3	μs

Silicon NPN Power Transistors

2SC4233

PACKAGE OUTLINE

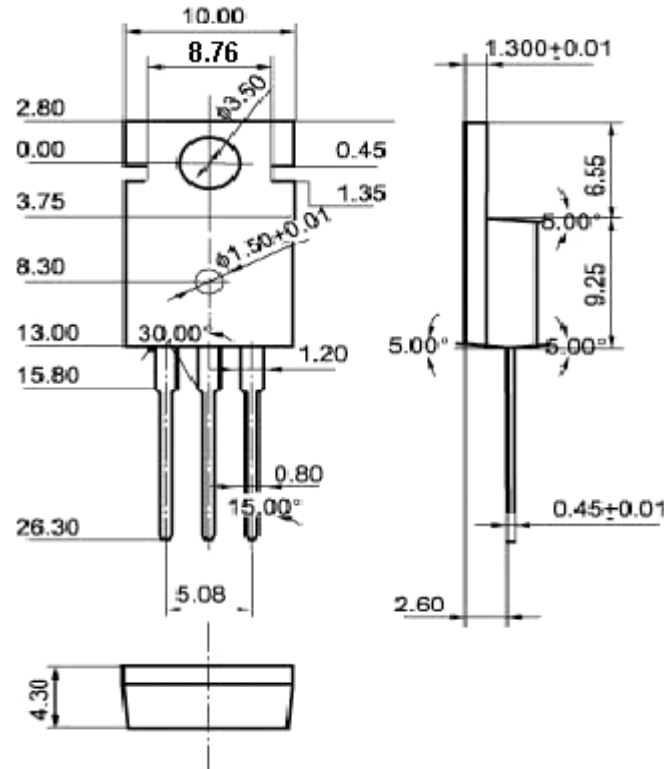

Fig.2 Outline dimensions (unindicated tolerance:±0.10 mm)