

NPN Transistors

2SC4272-HF

■ Features

- Collector Current Capability $I_C=1A$
- Collector Emitter Voltage $V_{CE0}=45V$
- Small Size Making It Easy To Provide High-Density,
To Provide High-Density,
- 27MHz CB Transceiver Driver Applications
- Pb-Free Package May be Available. The G-Suffix Denotes a
Pb-Free Lead Finish

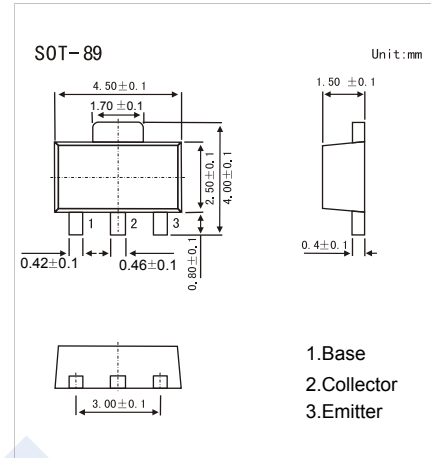

■ Absolute Maximum Ratings $T_a = 25^\circ C$

Parameter	Symbol	Rating	Unit
Collector - Base Voltage	V_{CBO}	75	V
Collector - Emitter Voltage	V_{CEO}	45	
Emitter - Base Voltage	V_{EBO}	5	
Collector Current - Continuous	I_C	1	A
Collector Current - Pulse	I_{CP}	1.5	
Collector Power Dissipation	P_C	1.3	W
Junction Temperature	T_J	150	$^\circ C$
Storage Temperature Range	T_{stg}	-55 to 150	

■ Electrical Characteristics $T_a = 25^\circ C$

Parameter	Symbol	Test Conditions	Min	Typ	Max	Unit
Collector- base breakdown voltage	V_{CBO}	$I_C = 100 \mu A, I_E = 0$	75			V
Collector- emitter breakdown voltage	V_{CEO}	$I_C = 1 mA, I_B = 0$	45			
Emitter - base breakdown voltage	V_{EBO}	$I_E = 100 \mu A, I_C = 0$	5			
Collector-base cut-off current	I_{CBO}	$V_{CB} = 40 V, I_E = 0$			1	μA
Emitter cut-off current	I_{EBO}	$V_{EB} = 4 V, I_C = 0$			1	
Collector-emitter saturation voltage	$V_{CE(sat)}$	$I_C = 500 mA, I_B = 50 mA$			0.6	V
Base - emitter saturation voltage	$V_{BE(sat)}$	$I_C = 500 mA, I_B = 50 mA$			1.2	
DC current gain	h_{FE}	$V_{CE} = 5V, I_C = 500 mA$	60		320	
Output Power	P_o	$V_{CC} = 12V, f = 27 MHz, P_{in} = 35 mW$	1			W
Collector Efficiency	η_C	See Test Circuit.	60			%
Collector output capacitance	C_{ob}	$V_{CB} = 10V, I_E = 0, f = 1 MHz$		15		pF
Transition frequency	f_T	$V_{CE} = 10V, I_C = 50 mA$		250		MHz

■ Classification of h_{FE}

Type	2SC4272-D-HF	2SC4272-E-HF	2SC4272-F-HF
Range	60-120	100-200	160-320
Marking	CHD* _F	CHE* _F	CHF* _F

NPN Transistors

2SC4272-HF

Test Circuit

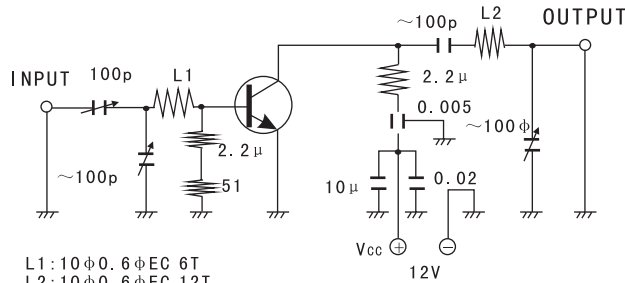

Unit (Resistance: Ω, Capacitance: F)

Typical Characteristics

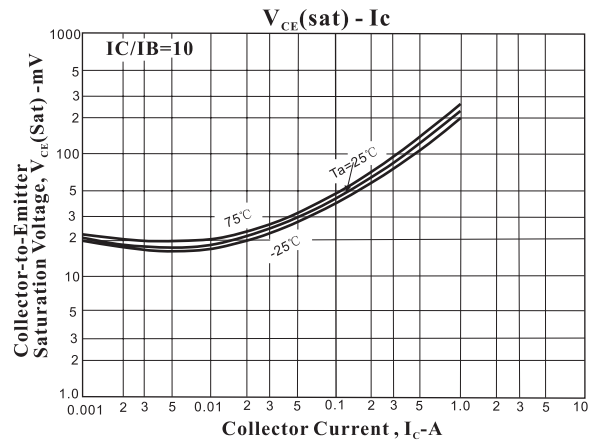
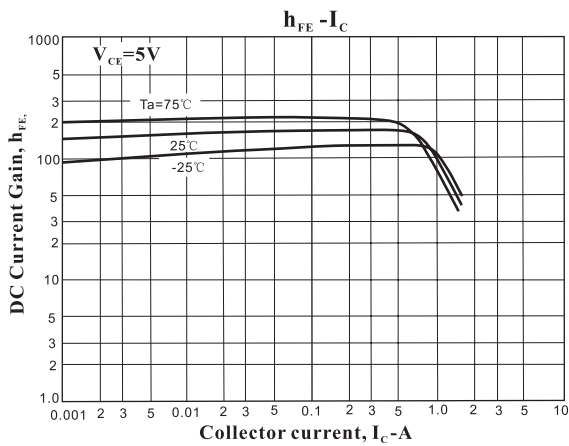
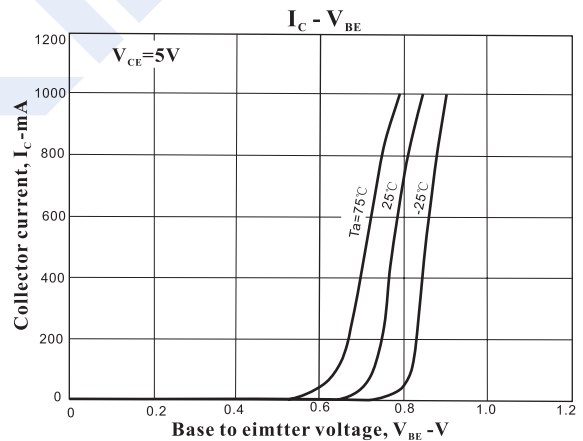
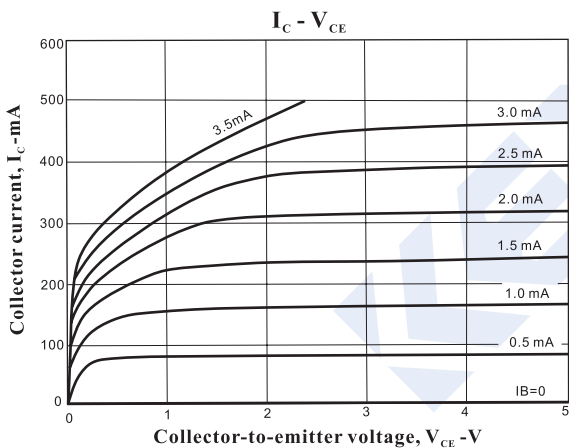

NPN Transistors 2SC4272-HF

■ Typical Characteristics

