

NPN Silicon Epitaxial Planar Transistor

2SC4373

FEATURES

- High transition frequency: $V_{CEO}=120V$.
- High voltage: $V_{CE(sat)}=0.5V(\text{Max})$.
- $P_C=1W$ (Mounted on ceramic substrate).
- Small flat package.
- Complementary: KTA1661.

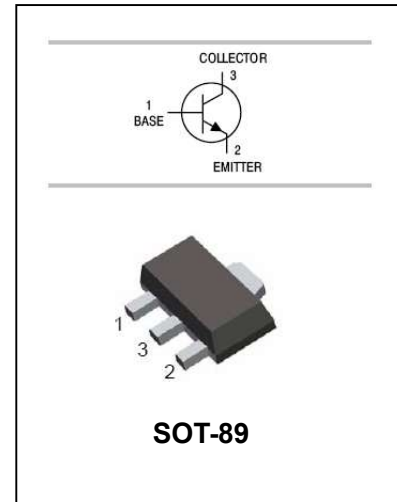

APPLICATIONS

- Power amplifier application.
- Power switching application.

ORDERING INFORMATION

Type No.	Marking	Package Code
2SC4373	CO/CY	SOT-89

MAXIMUM RATING @ $T_a=25^\circ\text{C}$ unless otherwise specified

Symbol	Parameter	Value	Units
V_{CBO}	Collector-Base Voltage	120	V
V_{CEO}	Collector-Emitter Voltage	120	V
V_{EBO}	Emitter-Base Voltage	5	V
I_C	Collector Current -Continuous	800	mA
I_B	Base current	160	mA
P_C	Collector Dissipation	500	mW
T_j, T_{stg}	Junction and Storage Temperature	-55 to +150	$^\circ\text{C}$

NPN Silicon Epitaxial Planar Transistor

2SC4373

ELECTRICAL CHARACTERISTICS @ Ta=25°C unless otherwise specified

Parameter	Symbol	Test conditions	MIN	TYP	MAX	UNIT
Collector-base breakdown voltage	$V_{(BR)CBO}$	$I_C=1mA, I_E=0$	120			V
Collector-emitter breakdown voltage	$V_{(BR)CEO}$	$I_C=10mA, I_B=0$	120			V
Emitter-base breakdown voltage	$V_{(BR)EBO}$	$I_E=1mA, I_C=0$	5			V
Collector cut-off current	I_{CBO}	$V_{CB}=120V, I_E=0$			0.1	μA
Emitter cut-off current	I_{EBO}	$V_{EB}=5V, I_C=0$			0.1	μA
DC current gain	h_{FE}	$V_{CE}=5V, I_C=100mA$	80		240	
Collector-emitter saturation voltage	$V_{CE(sat)}$	$I_C=500mA, I_B=50mA$			1.0	V
Base-emitter voltage	V_{BE}	$V_{CE}=5V, I_B=500mA$			1.0	V
Transition frequency	f_T	$V_{CE}=5V, I_C=0.1A$		120		MHz
Collector output capacitance	C_{ob}	$V_{CB}=10V, I_E=0, f=1MHz$			30	pF

CLASSIFICATION OF $h_{FE(1)}$

Rank	O	Y
Range	80-160	120-240
MARKING	CO	CY

NPN Silicon Epitaxial Planar Transistor

2SC4373

TYPICAL CHARACTERISTICS @ $T_a=25^\circ\text{C}$ unless otherwise specified

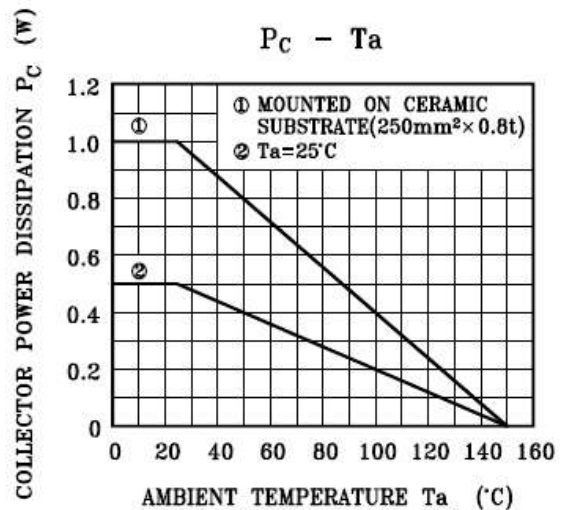
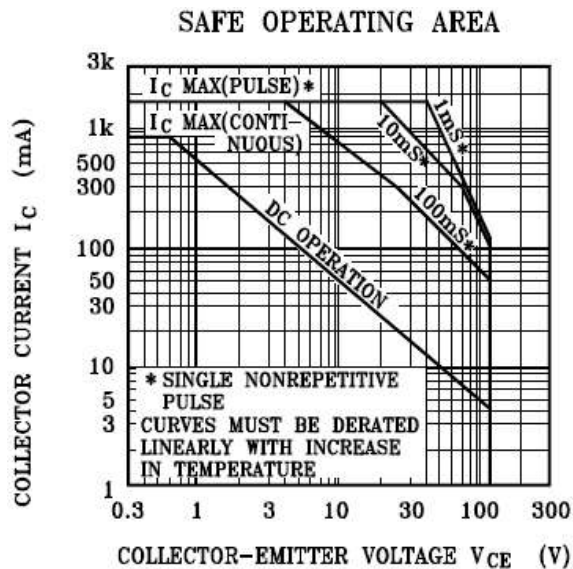
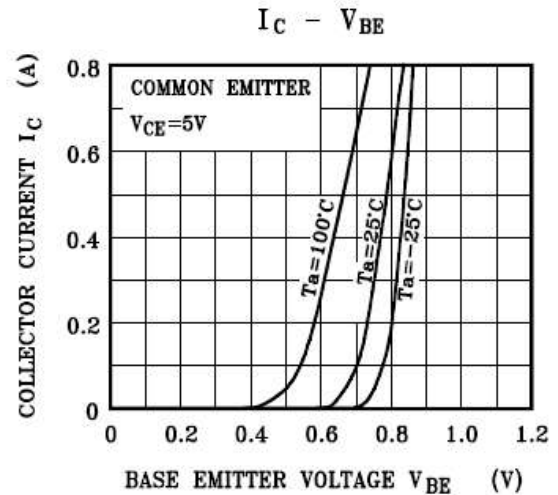
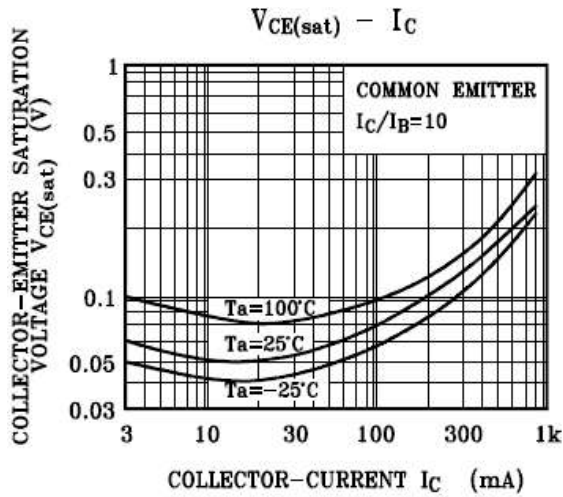
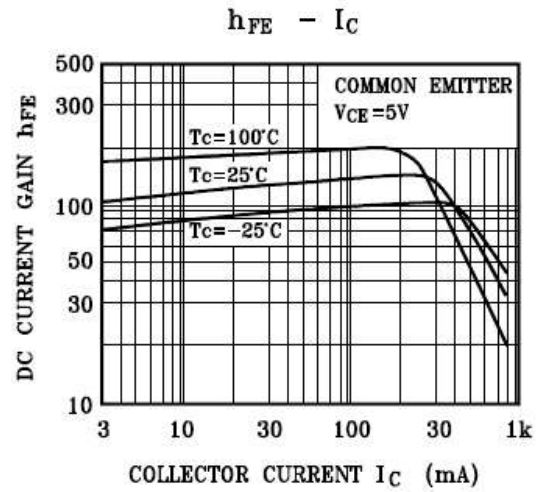
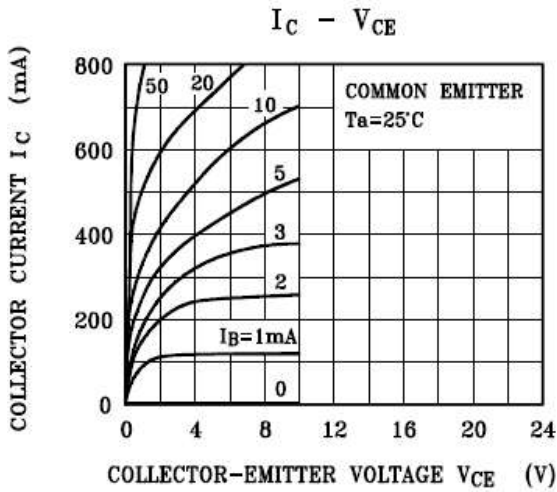

NPN Silicon Epitaxial Planar Transistor

2SC4373

PACKAGE OUTLINE

Plastic surface mounted package

SOT-89

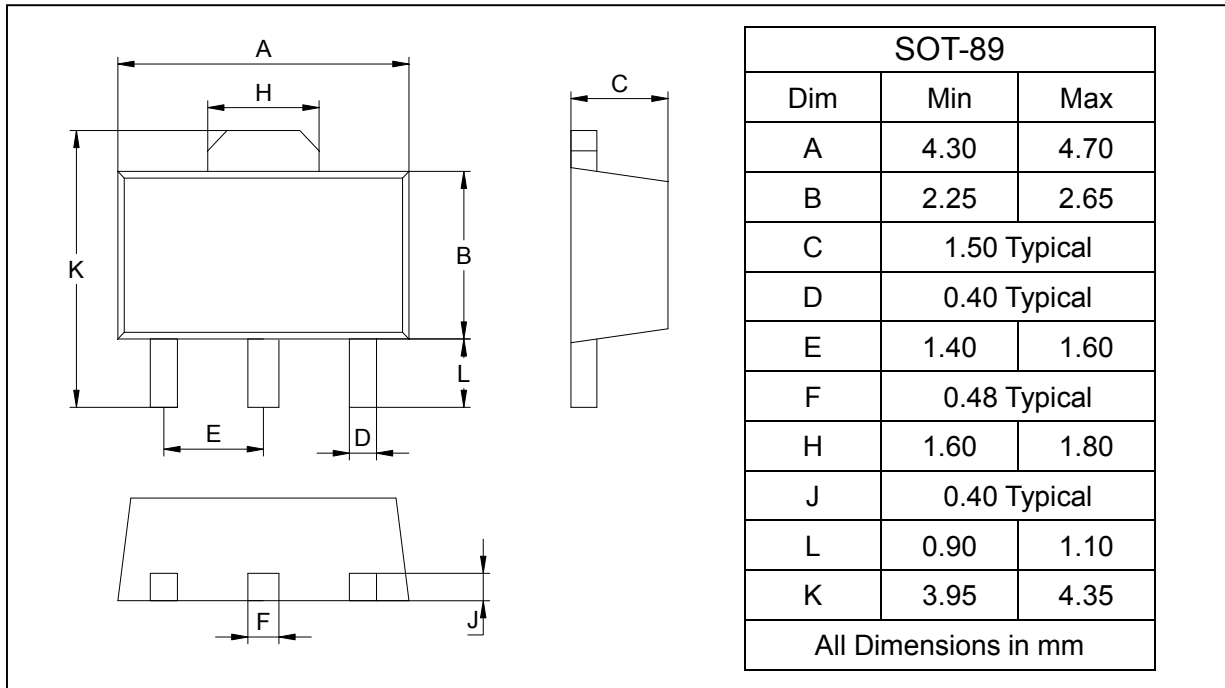

SOLDERING FOOTPRINT

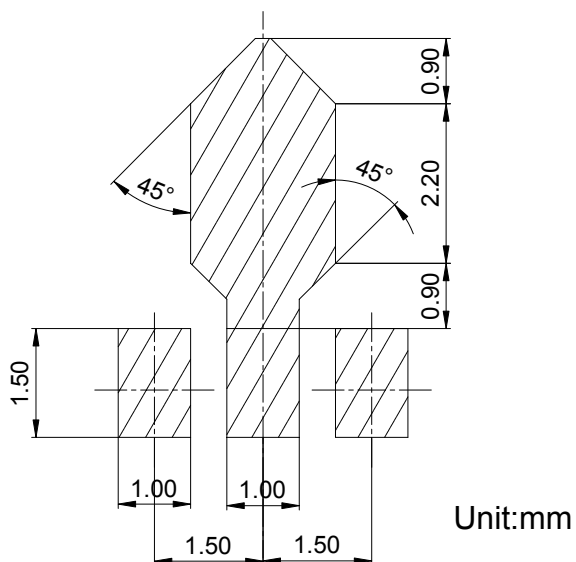

PACKAGE INFORMATION

Device	Package	Shipping
2SC4373	SOT-89	1000/Tape&Reel