

## Silicon NPN Power Transistors

2SC5196

## DESCRIPTION

- With TO-3P(I) package
- Complement to type 2SA1939

## APPLICATIONS

- Power amplifier applications
- Recommend for 40W high fidelity audio frequency amplifier output stage

## PINNING

PIN	DESCRIPTION
1	Base
2	Collector;connected to mounting base
3	Emitter

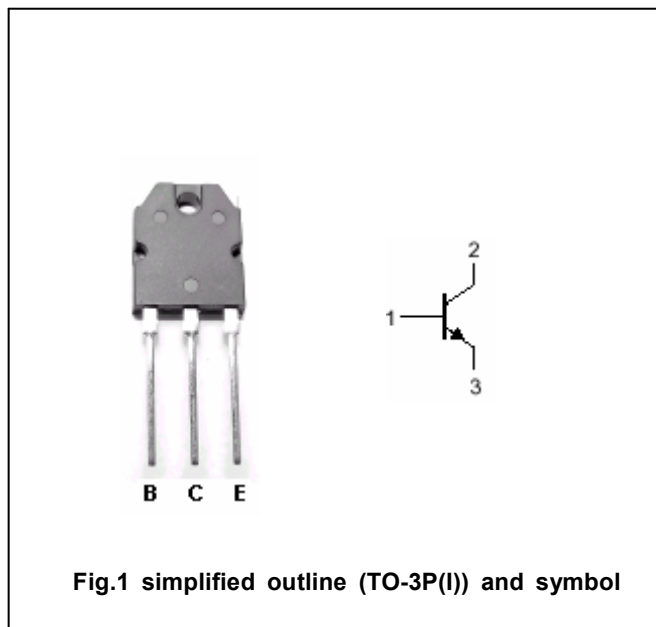
Absolute maximum ratings( $T_a=25^\circ\text{C}$ )

SYMBOL	PARAMETER	CONDITIONS	VALUE	UNIT
$V_{CBO}$	Collector-base voltage	Open emitter	80	V
$V_{CEO}$	Collector-emitter voltage	Open base	80	V
$V_{EBO}$	Emitter-base voltage	Open collector	5	V
$I_C$	Collector current		6	A
$I_B$	Base current		0.6	A
$P_C$	Collector power dissipation	$T_C=25^\circ\text{C}$	60	W
$T_j$	Junction temperature		150	$^\circ\text{C}$
$T_{stg}$	Storage temperature		-55~150	$^\circ\text{C}$

## Silicon NPN Power Transistors

## 2SC5196

## CHARACTERISTICS

T<sub>j</sub>=25°C unless otherwise specified

SYMBOL	PARAMETER	CONDITIONS	MIN	TYP.	MAX	UNIT
V <sub>(BR)CEO</sub>	Collector-emitter breakdown voltage	I <sub>C</sub> =50mA; I <sub>B</sub> =0	80			V
V <sub>CEsat</sub>	Collector-emitter saturation voltage	I <sub>C</sub> =5 A; I <sub>B</sub> =0.5A			2.0	V
V <sub>BE</sub>	Base-emitter voltage	I <sub>C</sub> =3A ; V <sub>CE</sub> =5V			1.5	V
I <sub>CBO</sub>	Collector cut-off current	V <sub>CB</sub> =80V; I <sub>E</sub> =0			5	μA
I <sub>EBO</sub>	Emitter cut-off current	V <sub>EB</sub> =5V; I <sub>C</sub> =0			5	μA
h <sub>FE-1</sub>	DC current gain	I <sub>C</sub> =1A ; V <sub>CE</sub> =5V	55		160	
h <sub>FE-2</sub>	DC current gain	I <sub>C</sub> =3A ; V <sub>CE</sub> =5V	35			
f <sub>T</sub>	Transition frequency	I <sub>C</sub> =1A ; V <sub>CE</sub> =5V		30		MHz
C <sub>OB</sub>	Output capacitance	I <sub>E</sub> =0; V <sub>CB</sub> =10V; f=1MHz		75		pF

◆ h<sub>FE-1</sub> classifications

R	O
55-110	80-160

Silicon NPN Power Transistors

2SC5196

PACKAGE OUTLINE

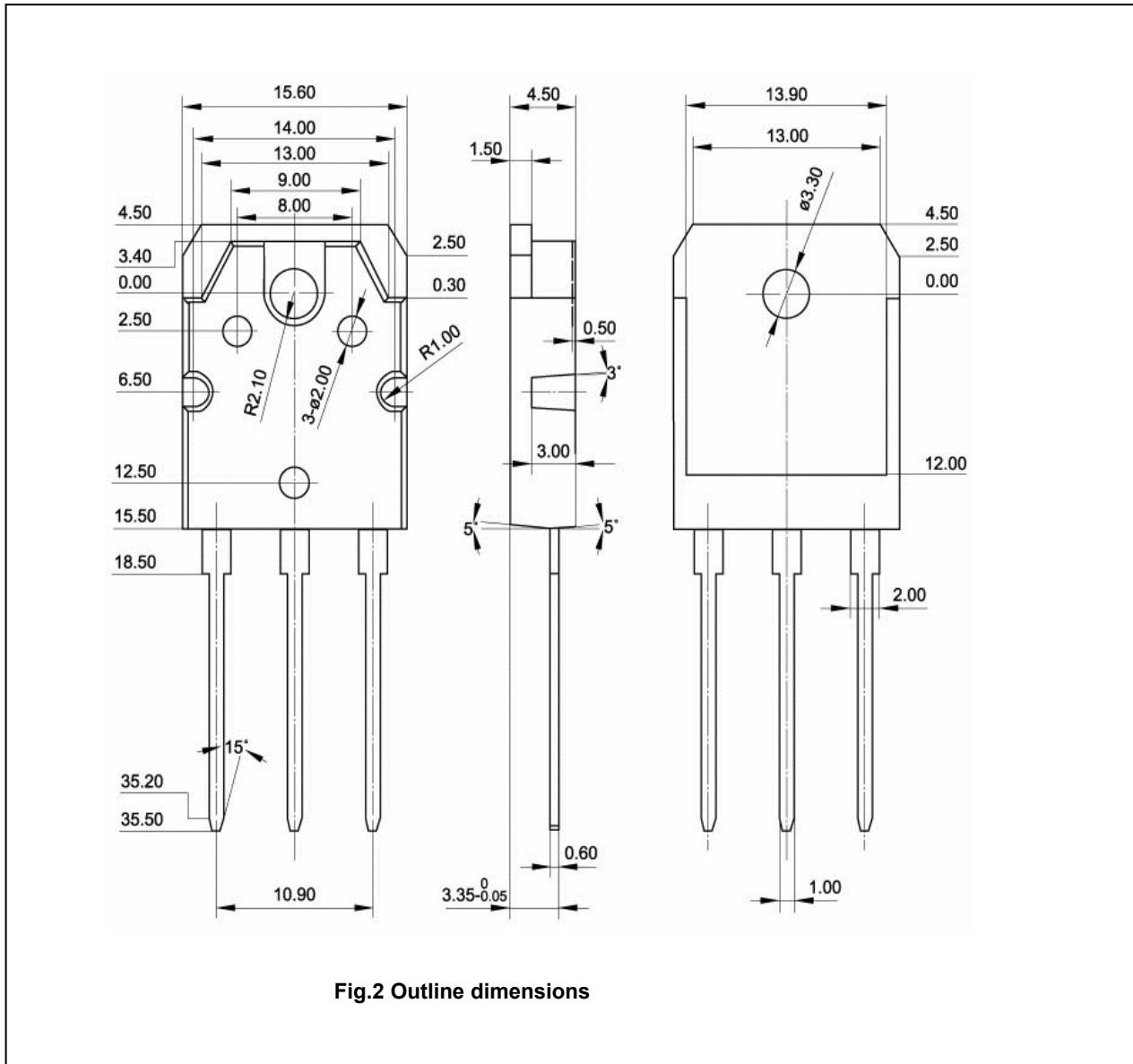

Fig.2 Outline dimensions

Silicon NPN Power Transistors

2SC5196

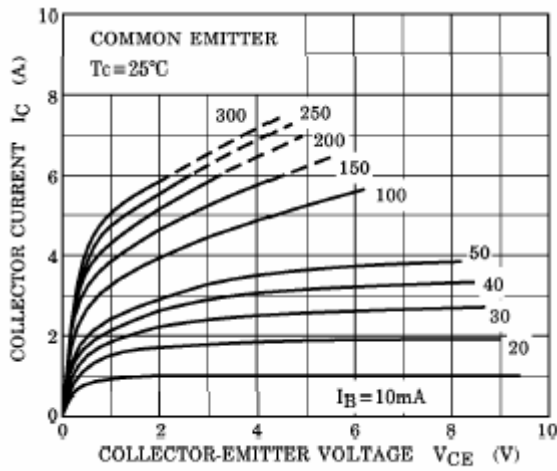

Fig.3 Static Characteristic

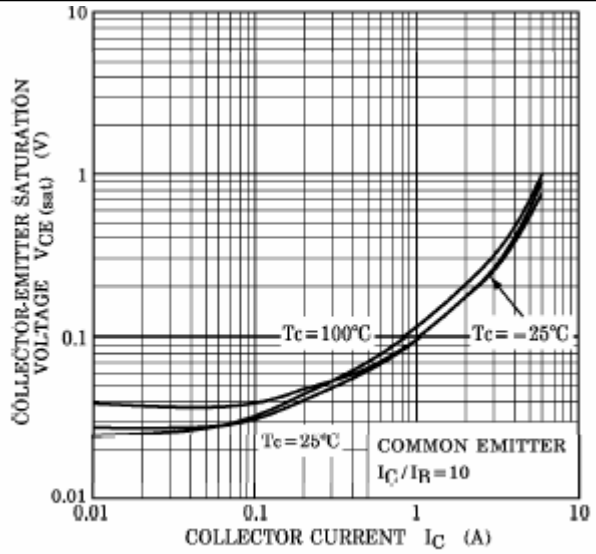

Fig.4 Collector-Emitter Saturation Voltage

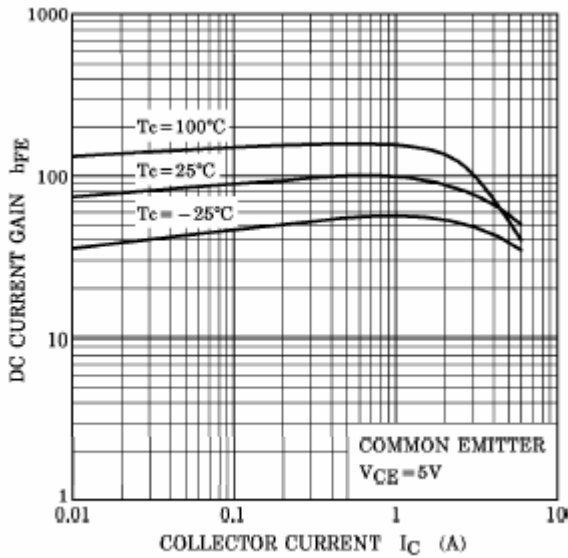

Fig.5 DC current Gain

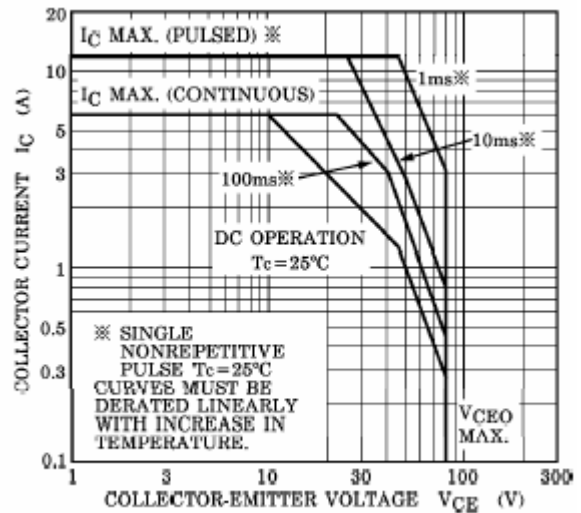

Fig.6 Safe Operating Area