

---

# 2SC5469

Silicon NPN Triple Diffused  
Character Display Horizontal Deflection Output

## HITACHI

3rd. Edition  
December 1997  
Target Specification

---

### Features

- High breakdown voltage  
 $V_{CBO} = 1500 \text{ V}$
- High speed switching  
 $t_r = 0.15 \mu\text{sec (typ.)}$  at  $f_H = 64\text{kHz}$

### Outline

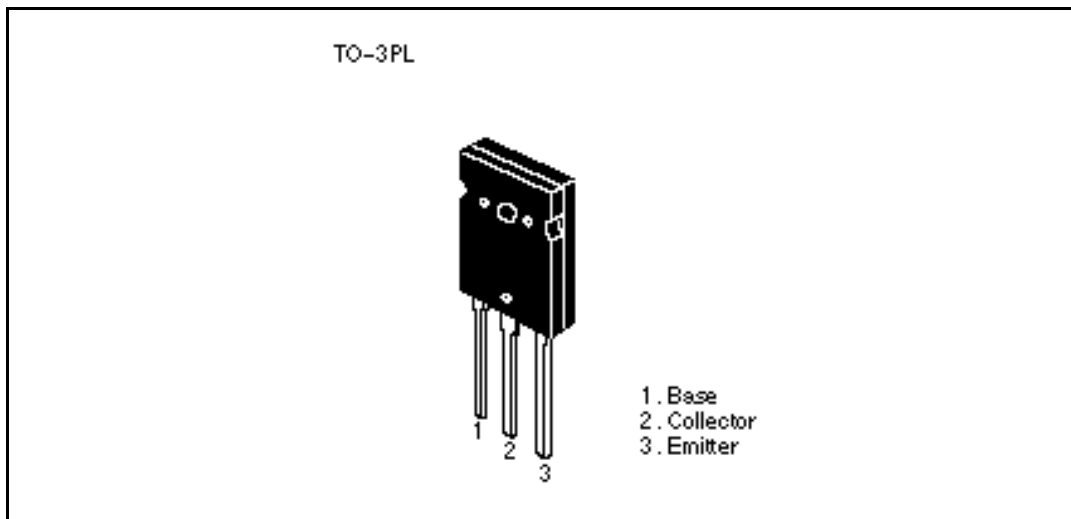

## 2SC5469

### Absolute Maximum Ratings (Ta = 25°C)

Item	Symbol	Ratings	Unit
Collector to base voltage	$V_{CBO}$	1500	V
Collector to emitter voltage	$V_{CEO}$	700	V
Emitter to base voltage	$V_{EBO}$	6	V
Collector current	$I_C$	15	A
Collector peak current	$i_{c(peak)}$	30	A
Collector power dissipation	$P_C$ <sup>Note1</sup>	125	W
Junction temperature	$T_j$	150	°C
Storage temperature	$T_{stg}$	-55 to +150	°C

Note: 1. Value at  $T_c = 25^\circ\text{C}$

### Electrical Characteristics (Ta = 25°C)

Item	Symbol	Min	Typ	Max	Unit	Test Conditions
Collector to emitter breakdown voltage	$V_{(BR)CEO}$	700	—	—	V	$I_C = 10\text{mA}$ , $R_{BE} =$
Emitter to base breakdown voltage	$V_{(BR)EBO}$	6	—	—	V	$I_E = 10\text{mA}$ , $I_C = 0$
Collector cutoff current	$I_{CES}$	—	—	500	$\mu\text{A}$	$V_{CE} = 1500\text{V}$ , $R_{BE} = 0$
DC current transfer ratio	$h_{FE1}$	10	—	40		$V_{CE} = 5\text{V}$ , $I_C = 1\text{A}$
DC current transfer ratio	$h_{FE2}$	3.5	—	6.5		$V_{CE} = 5\text{V}$ , $I_C = 8\text{A}$
Collector to emitter saturation voltage	$V_{CE(sat)}$	—	—	5	V	$I_C = 10\text{A}$ , $I_B = 3\text{A}$
Base to emitter saturation voltage	$V_{BE(sat)}$	—	—	1.5	V	$I_C = 10\text{A}$ , $I_B = 3\text{A}$
Fall time	$t_f$	—	0.2	0.4	$\mu\text{s}$	$I_{CP} = 7\text{A}$ , $I_{B1} = 2.8\text{A}$ $f_H = 31.5\text{kHz}$
Fall time	$t_f$	—	0.15	—	$\mu\text{s}$	$I_{CP} = 7\text{A}$ , $I_{B1} = 1.8\text{A}$ $f_H = 64\text{kHz}$

Package Dimensions

Unit: mm

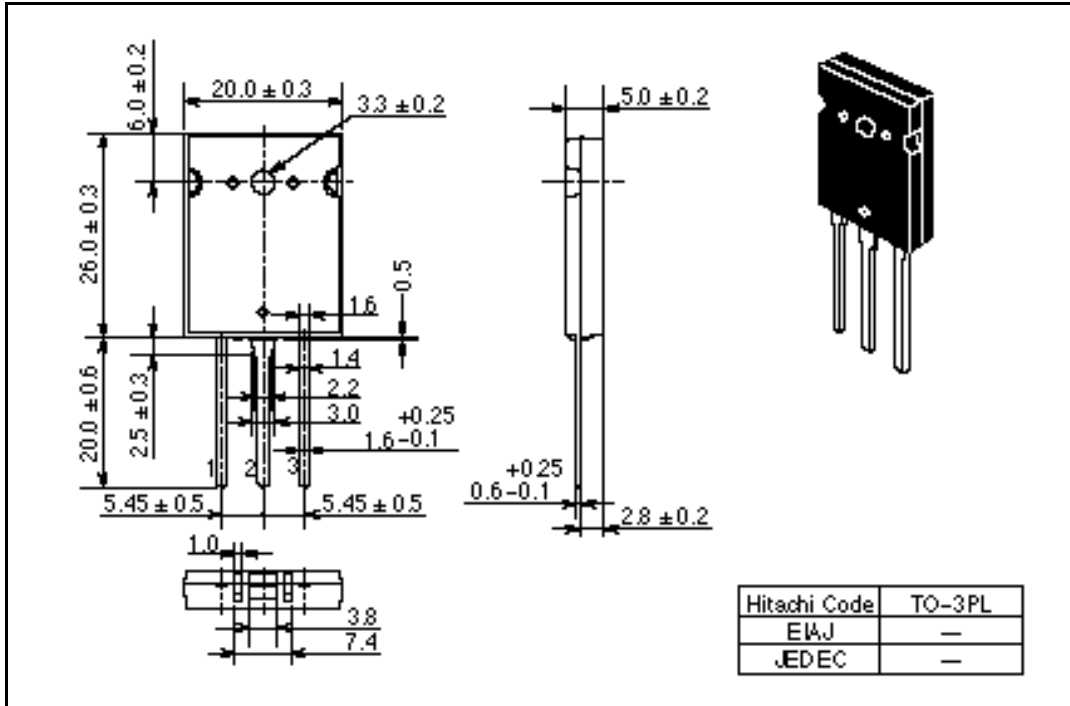

When using this document, keep the following in mind:

1. This document may, wholly or partially, be subject to change without notice.
2. All rights are reserved: No one is permitted to reproduce or duplicate, in any form, the whole or part of this document without Hitachi's permission.
3. Hitachi will not be held responsible for any damage to the user that may result from accidents or any other reasons during operation of the user's unit according to this document.
4. Circuitry and other examples described herein are meant merely to indicate the characteristics and performance of Hitachi's semiconductor products. Hitachi assumes no responsibility for any intellectual property claims or other problems that may result from applications based on the examples described herein.
5. No license is granted by implication or otherwise under any patents or other rights of any third party or Hitachi, Ltd.
6. **MEDICAL APPLICATIONS:** Hitachi's products are not authorized for use in **MEDICAL APPLICATIONS** without the written consent of the appropriate officer of Hitachi's sales company. Such use includes, but is not limited to, use in life support systems. Buyers of Hitachi's products are requested to notify the relevant Hitachi sales offices when planning to use the products in **MEDICAL APPLICATIONS**.

---

---

# HITACHI

## Hitachi, Ltd.

Semiconductor & IC Div.

Nippon Bldg., 2-5-2, Ohite-machi, Chiyoda-ku, Tokyo 100, Japan

Tel: Tokyo (03) 3270-2111

Fax: (03) 3270-5109

For further information write to:

Hitachi America, Ltd.

Semiconductor & IC Div.

2000 Sierra Point Parkway

Brisbane, CA, 94005-1835

U.S.A.

Tel: 415-899-8300

Fax: 415-893-4207

Hitachi Europe GmbH

Electronic Components Group

Continental Europe

Darnecker Straße 3

D-85622 Feldkirchen

München

Tel: 089-9 94 80-0

Fax: 089-9 29 30 00

Hitachi Europe Ltd.

Electronic Components Div.

Northern Europe Headquarters

Whitebrook Park

Lower Cookham Road

Midlehead

Berkshire SL6 3YX

United Kingdom

Tel: 0628-585000

Fax: 0628-778322

Hitachi Asia Pte. Ltd.

15 Collyer Quay #20-00

Hitachi Tower

Singapore 0404

Tel: 535-2400

Fax: 535-1533

Hitachi Asia (Hong Kong) Ltd.

Unit 705, North Tower,

World Finance Centre,

Harbour City, Canton Road

Tsim Sha Tsui, Kowloon

Hong Kong

Tel: 27389218

Fax: 27306074

Copyright ©Hitachi, Ltd., 1997. All rights reserved. Printed in Japan.