

## Silicon NPN Power Transistors

2SD1023

## DESCRIPTION

- With TO-220 package
- High DC current gain
- DARLINGTON

## PINNING

PIN	DESCRIPTION
1	Base
2	Collector;connected to mounting base
3	Emitter

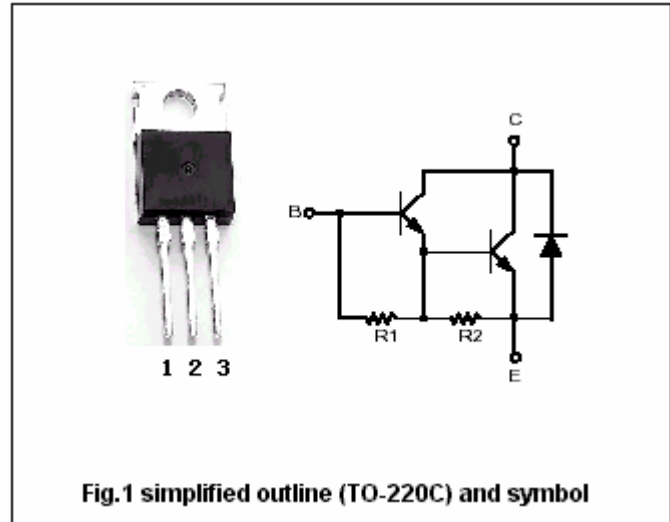

Fig.1 simplified outline (TO-220C) and symbol

## Absolute maximum ratings (Ta=25℃)

SYMBOL	PARAMETER	CONDITIONS	VALUE	UNIT
V <sub>CB0</sub>	Collector-base voltage	Open emitter	200	V
V <sub>CEO</sub>	Collector-emitter voltage	Open base	200	V
V <sub>EBO</sub>	Emitter-base voltage	Open collector	7	V
I <sub>C</sub>	Collector current-Continuous		5	A
I <sub>CM</sub>	Collector current-Peak		8	A
I <sub>B</sub>	Base current		0.5	A
I <sub>BM</sub>	Base current-Peak		1	A
P <sub>T</sub>	Total power dissipation	T <sub>C</sub> =25℃	30	W
T <sub>j</sub>	Junction temperature		150	℃
T <sub>stg</sub>	Storage temperature		-55~150	℃

## THERMAL CHARACTERISTICS

SYMBOL	PARAMETER	VALUE	UNIT
R <sub>th j-c</sub>	Thermal resistance junction to case	4.17	℃/W

## Silicon NPN Power Transistors

## 2SD1023

## CHARACTERISTICS

T<sub>j</sub>=25°C unless otherwise specified

www.datasheet4u.com

SYMBOL	PARAMETER	CONDITIONS	MIN	TYP.	MAX	UNIT
V <sub>CEsat</sub>	Collector-emitter saturation voltage	I <sub>C</sub> =3A; I <sub>B</sub> =5mA			1.5	V
V <sub>BEsat</sub>	Base-emitter saturation voltage	I <sub>C</sub> =3A; I <sub>B</sub> =5mA			2.0	V
I <sub>CEO</sub>	Collector cut-off current	V <sub>CE</sub> =200V; I <sub>B</sub> =0			0.1	mA
I <sub>CBO</sub>	Collector cut-off current	V <sub>CB</sub> =200V; I <sub>E</sub> =0			0.1	mA
I <sub>EBO</sub>	Emitter cut-off current	V <sub>EB</sub> =7V; I <sub>C</sub> =0			5	mA
h <sub>FE</sub>	DC current gain	I <sub>C</sub> =3A; V <sub>CE</sub> =3V	1500		30000	
f <sub>T</sub>	Transition frequency	I <sub>C</sub> =0.5A; V <sub>CE</sub> =10V		20		MHz
t <sub>on</sub>	Turn-on time	I <sub>C</sub> =3A; I <sub>B</sub> =5mA R <sub>L</sub> =10Ω V <sub>BB2</sub> =4V			2	μs
t <sub>s</sub>	Storage time				8	μs
t <sub>f</sub>	Fall time				5	μs

Silicon NPN Power Transistors

2SD1023

PACKAGE OUTLINE

www.datasheet4u.com

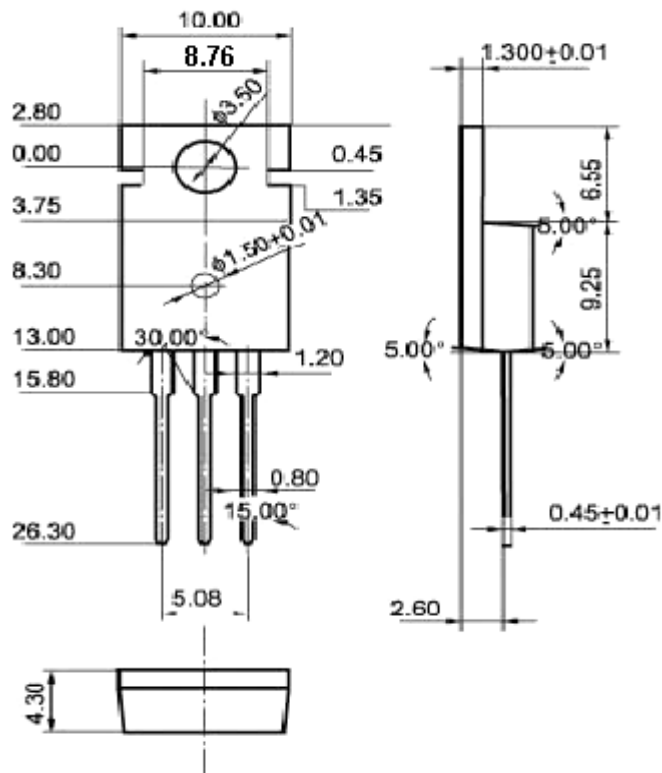

Fig.2 Outline dimensions (unindicated tolerance: 0.1mm)