

Silicon NPN Power Transistors

2SD1024

DESCRIPTION

www.datasheet4u.com

- With TO-220 package
- High DC current gain
- DARLINGTON

PINNING

PIN	DESCRIPTION
1	Base
2	Collector;connected to mounting base
3	Emitter

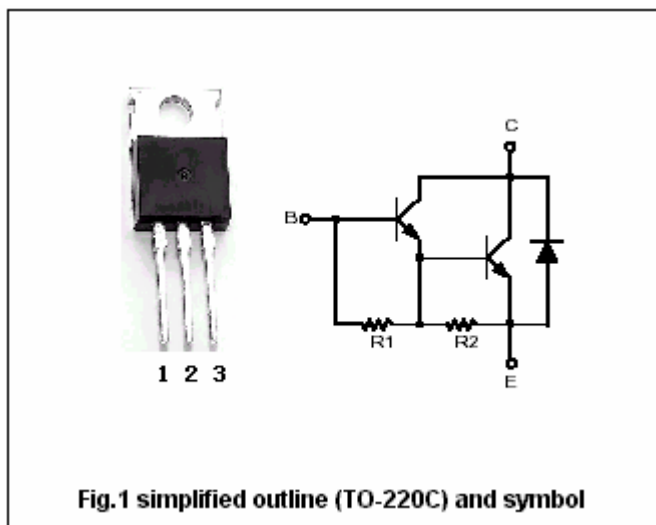

Fig.1 simplified outline (TO-220C) and symbol

Absolute maximum ratings (Ta=25°C)

SYMBOL	PARAMETER	CONDITIONS	VALUE	UNIT
V _{CBO}	Collector-base voltage	Open emitter	100	V
V _{CEO}	Collector-emitter voltage	Open base	100	V
V _{EBO}	Emitter-base voltage	Open collector	7	V
I _C	Collector current-Continuous		8	A
I _{CM}	Collector current-Peak		12	A
I _B	Base current		0.5	A
I _{BM}	Base current-Peak		1	A
P _T	Total power dissipation	T _C =25°C	50	W
T _j	Junction temperature		150	°C
T _{stg}	Storage temperature		-55~150	°C

THERMAL CHARACTERISTICS

SYMBOL	PARAMETER	VALUE	UNIT
R _{th j-c}	Thermal resistance junction to case	2.5	°C/W

Silicon NPN Power Transistors

2SD1024

CHARACTERISTICS

T_j=25°C unless otherwise specified

www.datasheet4u.com

SYMBOL	PARAMETER	CONDITIONS	MIN	TYP.	MAX	UNIT
V _{CEsat}	Collector-emitter saturation voltage	I _C =5A; I _B =6mA			1.5	V
V _{BEsat}	Base-emitter saturation voltage	I _C =5A; I _B =6mA			2.0	V
I _{CEO}	Collector cut-off current	V _{CE} =100V; I _B =0			0.1	mA
I _{CBO}	Collector cut-off current	V _{CB} =100V; I _E =0			0.1	mA
I _{EBO}	Emitter cut-off current	V _{EB} =7V; I _C =0			5	mA
h _{FE}	DC current gain	I _C =5A ; V _{CE} =3V	1500		30000	
f _T	Transition frequency	I _C =0.8A ; V _{CE} =10V		20		MHz

Switching times

t _{on}	Turn-on time	I _C =8A; I _{B1} =I _{B2} =8mA R _L =3Ω; V _{BB2} =4V			2	μs
t _s	Storage time				5	μs
t _f	Fall time				3	μs

Silicon NPN Power Transistors

2SD1024

PACKAGE OUTLINE

www.datasheet4u.com

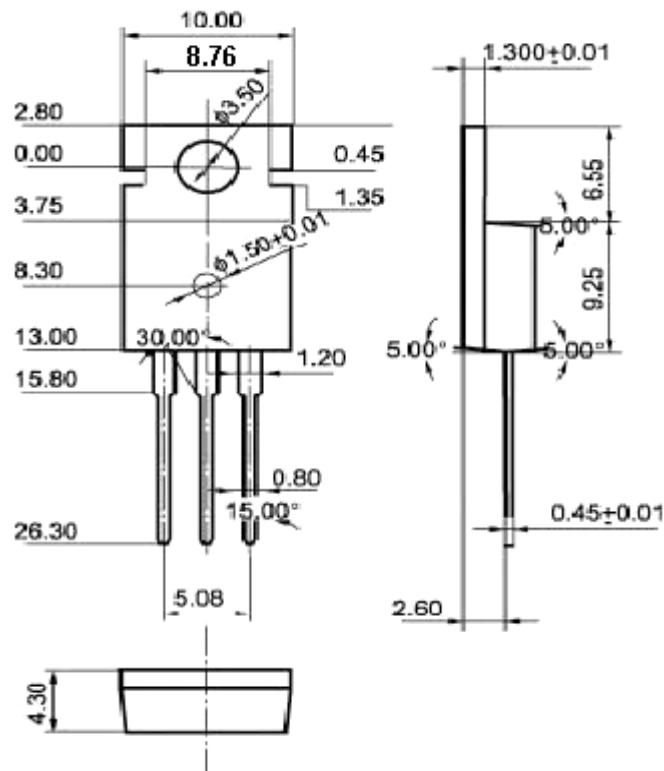

Fig.2 Outline dimensions (unindicated tolerance: 0.1mm)