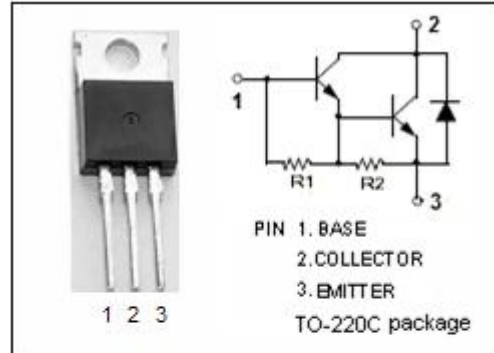

isc Silicon NPN Darlington Power Transistor
2SD1190
DESCRIPTION

- Collector-Emitter Breakdown Voltage-
: $V_{(BR)CEO} = 60V(\text{Min})$
- High DC Current Gain
: $h_{FE} = 2000(\text{Min}) @ I_C = 2A$
- Low Saturation Voltage
- Complement to Type 2SB880
- Minimum Lot-to-Lot variations for robust device performance and reliable operation

APPLICATIONS

- Designed for motor drivers, printer hammer drivers, relay drivers, voltage regulator applications

ABSOLUTE MAXIMUM RATINGS($T_a=25^\circ\text{C}$)

SYMBOL	PARAMETER	VALUE	UNIT
V_{CBO}	Collector-Base Voltage	70	V
V_{CEO}	Collector-Emitter Voltage	60	V
V_{EBO}	Emitter-Base Voltage	6	V
I_C	Collector Current-Continuous	4	A
I_{CP}	Collector Current-Peak	6	A
P_C	Collector Power Dissipation @ $T_a=25^\circ\text{C}$	1.75	W
	Collector Power Dissipation @ $T_c=25^\circ\text{C}$	30	
T_J	Junction Temperature	150	$^\circ\text{C}$
T_{stg}	Storage Temperature Range	-55~150	$^\circ\text{C}$

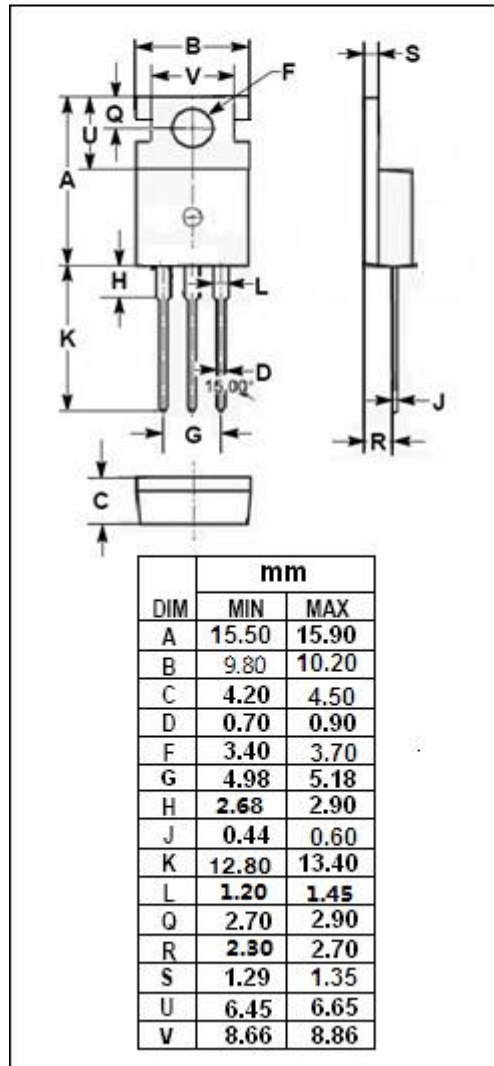

isc Silicon NPN Darlington Power Transistor**2SD1190****ELECTRICAL CHARACTERISTICS** $T_C=25^\circ\text{C}$ unless otherwise specified

SYMBOL	PARAMETER	CONDITIONS	MIN	TYP.	MAX	UNIT
$V_{(BR)CEO}$	Collector-Emitter Breakdown Voltage	$I_C=30\text{mA}; R_{BE}=\infty$	60			V
$V_{(BR)CBO}$	Collector-Base Breakdown Voltage	$I_C=1\text{mA}; I_E=0$	70			V
$V_{CE(sat)}$	Collector-Emitter Saturation Voltage	$I_C=2\text{A}; I_B=4\text{mA}$			1.5	V
$V_{BE(sat)}$	Base-Emitter Saturation Voltage	$I_C=2\text{A}; I_B=4\text{mA}$			2.0	V
I_{CBO}	Collector Cutoff Current	$V_{CB}=40\text{V}; I_E=0$			100	μA
I_{EBO}	Emitter Cutoff Current	$V_{EB}=5\text{V}; I_C=0$			3.0	mA
h_{FE}	DC Current Gain	$I_C=2\text{A}; V_{CE}=2\text{V}$	2000			
f_T	Current-Gain—Bandwidth Product	$I_C=2\text{A}; V_{CE}=5\text{V}$		20		MHz

Switching times

t_{on}	Turn-on Time	$I_C=2\text{A}, I_{B1}=I_{B2}=4\text{mA}$ $P_W=50\mu\text{s}; \text{Duty Cycle}\leq 1\%$		0.6		μs
t_{stg}	Storage Time			2.7		μs
t_f	Fall Time			1.6		μs

**NOTICE:**

ISC reserves the rights to make changes of the content herein the datasheet at any time without notification. The information contained herein is presented only as a guide for the applications of our products.

ISC products are intended for usage in general electronic equipment. The products are not designed for use in equipment which require specialized quality and/or reliability, or in equipment which could have applications in hazardous environments, aerospace industry, or medical field. Please contact us if you intend our products to be used in these special applications.

ISC makes no warranty or guarantee regarding the suitability of its products for any particular purpose, nor does ISC assume any liability arising from the application or use of any products, and specifically disclaims any and all liability, including without limitation special, consequential or incidental damages.