

NPN Transistors

2SD1221

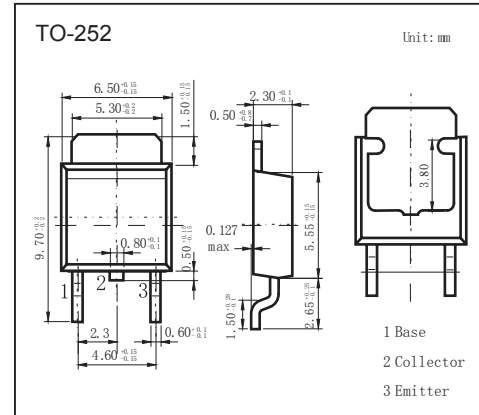

Features

- Low collector saturation voltage
: $V_{CE(sat)} = 0.4\text{ V (typ.)}$ ($I_C = 3\text{ A}$, $I_B = 0.3\text{ A}$)
- High power dissipation: $P_C = 20\text{ W}$ ($T_C = 25^\circ\text{C}$)
- Complementary to 2SB906

Absolute Maximum Ratings $T_a = 25^\circ\text{C}$

Parameter	Symbol	Rating	Unit	
Collector - Base Voltage	V_{CB0}	60	V	
Collector - Emitter Voltage	V_{CE0}	60		
Emitter - Base Voltage	V_{EB0}	7		
Collector Current - Continuous	I_C	3	A	
Base Current	I_B	0.5		
Collector Power Dissipation	P_C	$T_a = 25^\circ\text{C}$	1	W
		$T_C = 25^\circ\text{C}$	20	
Junction Temperature	T_J	150	$^\circ\text{C}$	
Storage Temperature Range	T_{stg}	-55 to 150		

Electrical Characteristics $T_a = 25^\circ\text{C}$

Parameter	Symbol	Test Conditions	Min	Typ	Max	Unit
Collector- base breakdown voltage	V_{CB0}	$I_C = 100\ \mu\text{A}$, $I_E = 0$	60			V
Collector- emitter breakdown voltage	V_{CE0}	$I_C = 50\ \text{mA}$, $I_B = 0$	60			
Emitter - base breakdown voltage	V_{EB0}	$I_E = 100\ \mu\text{A}$, $I_C = 0$	7			
Collector-base cut-off current	I_{CB0}	$V_{CB} = 60\ \text{V}$, $I_E = 0$			0.1	μA
Emitter cut-off current	I_{EB0}	$V_{EB} = 7\ \text{V}$, $I_C = 0$			0.1	
Collector-emitter saturation voltage	$V_{CE(sat)}$	$I_C = 3\ \text{A}$, $I_B = 300\ \text{mA}$		0.4	1	V
Base - emitter saturation voltage	$V_{BE(sat)}$	$I_C = 3\ \text{A}$, $I_B = 300\ \text{mA}$			1.2	
Base - emitter voltage	V_{BE}	$V_{CE} = 5\ \text{V}$, $I_C = 500\ \text{mA}$		0.7	1	
DC current gain	$h_{FE(1)}$	$V_{CE} = 5\ \text{V}$, $I_C = 500\ \text{mA}$	60		300	
	$h_{FE(2)}$	$V_{CE} = 5\ \text{V}$, $I_C = 3\ \text{A}$	20			
Turn-on time	t_{on}	See specified Test Circuit		0.8		μs
Storage time	t_{stg}			1.5		
Fall time	t_f			0.8		
Collector output capacitance	C_{ob}	$V_{CB} = 10\ \text{V}$, $I_E = 0$, $f = 1\ \text{MHz}$		70		pF
Transition frequency	f_T	$V_{CE} = 5\ \text{V}$, $I_C = 500\ \text{mA}$		3		MHz

Classification of $h_{FE(1)}$

Type	2SD1221-O	2SD1221-Y	2SD1221-G
Range	60-120	100-200	150-300

NPN Transistors

2SD1221

Switching Time Test Circuit

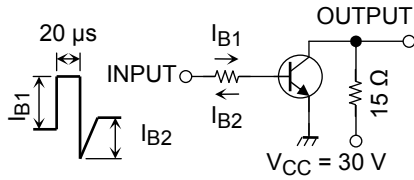

$I_{B1} = -I_{B2} = 0.2 \text{ A}$, DUTY CYCLE $\leq 1\%$

Typical Characteristics

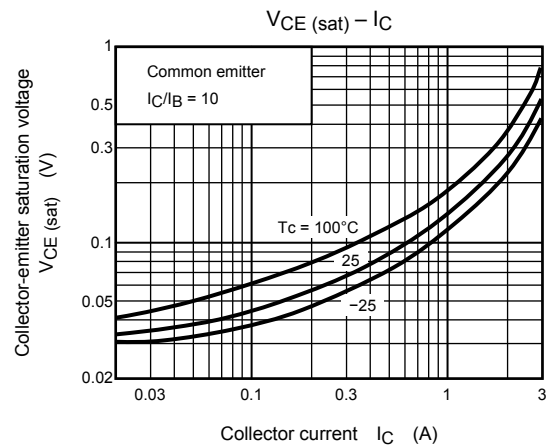
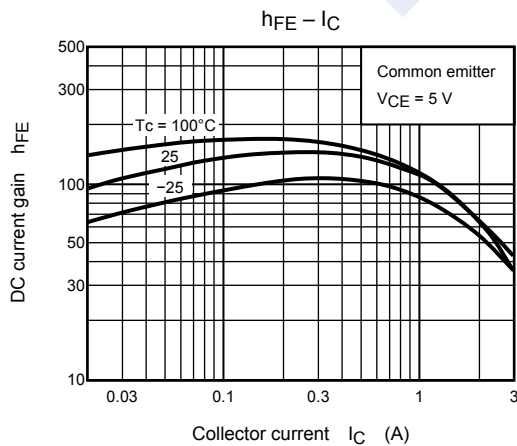
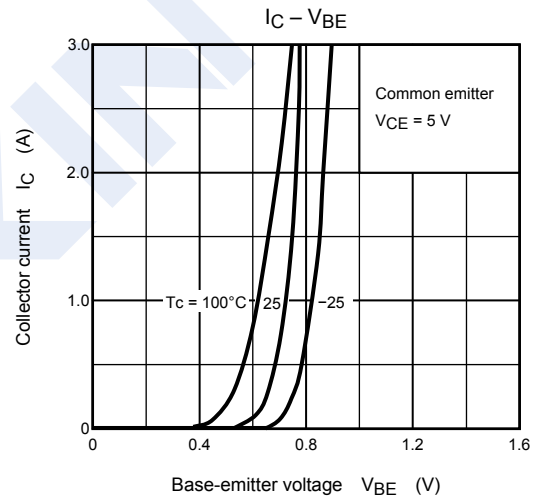
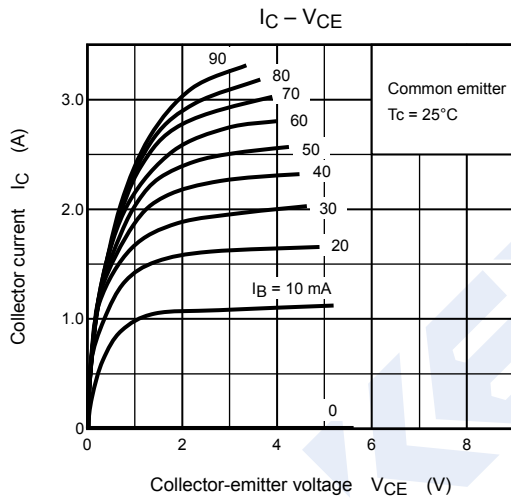

NPN Transistors

2SD1221

■ Typical Characteristics

