

Silicon NPN Power Transistors

2SD1274 2SD1274A 2SD1274B

DESCRIPTION

www.datasheet4u.com

- With TO-220Fa package
- High V_{CBO}
- High speed switching

APPLICATIONS

- Power amplifier applicaitons

PINNING

PIN	DESCRIPTION
1	Base
2	Collector
3	Emitter

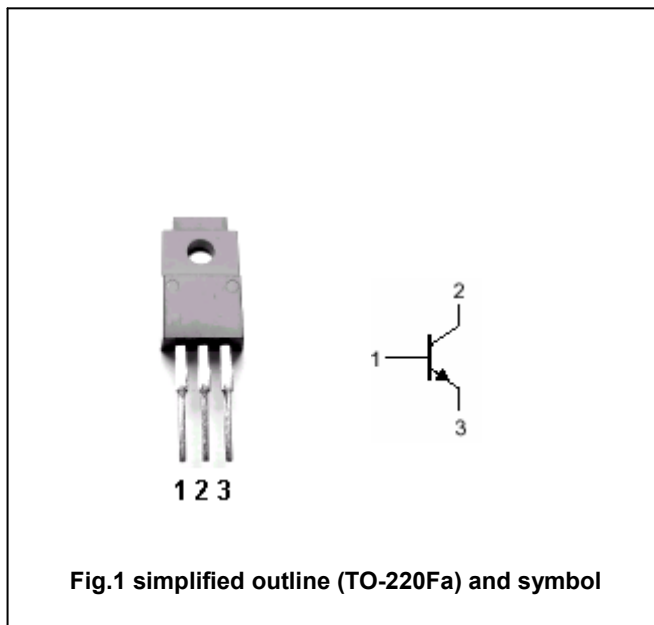

Absolute maximum ratings ($T_a=25^\circ\text{C}$)

SYMBOL	PARAMETER	CONDITIONS	VALUE	UNIT
V_{CBO}	Collector-base voltage	2SD1274	150	V
		2SD1274A	200	
		2SD1274B	250	
V_{CEO}	Collector-emitter voltage	Open base	80	V
V_{EBO}	Emitter-base voltage	Open collector	6	V
I_C	Collector current (DC)		5	A
P_C	Collector power dissipation	$T_C=25^\circ\text{C}$	40	W
		$T_a=25^\circ\text{C}$	2	
T_j	Junction temperature		150	$^\circ\text{C}$
T_{stg}	Storage temperature		-55~150	$^\circ\text{C}$

Silicon NPN Power Transistors

2SD1274 2SD1274A 2SD1274B

CHARACTERISTICS

T_j=25°C unless otherwise specified

www.datasheet4u.com

SYMBOL	PARAMETER	CONDITIONS	MIN	TYP.	MAX	UNIT	
V _{CEO(SUS)}	Collector-emitter sustaining voltage	I _C =0.2A, L=25mH	80			V	
V _{(BR)EBO}	Emitter-base breakdown voltage	I _E =1mA, I _C =0	6			V	
V _{CEsat}	Collector-emitter saturation voltage	I _C =5A; I _B =1A			1.6	V	
V _{BE}	Base-emitter voltage	I _C =5A; V _{CE} =4V			1.5	V	
I _{CBO}	Collector cut-off current	2SD1274			1	mA	
		2SD1274A					V _{CB} =150V; I _E =0
		2SD1274B					V _{CB} =200V; I _E =0
	2SD1274B	V _{CB} =250V; I _E =0					
I _{EBO}	Emitter cut-off current	V _{EB} =5V; I _C =0			50	μA	
h _{FE}	DC current gain	I _C =5A; V _{CE} =4V	14				
f _T	Transition frequency	I _C =0.5A; V _{CE} =10V		40		MHz	
t _f	Fall time	I _C =5A; I _{B1} =0.8A V _{EB} =-5V			1.0	μs	

PACKAGE OUTLINE

www.datasheet4u.com

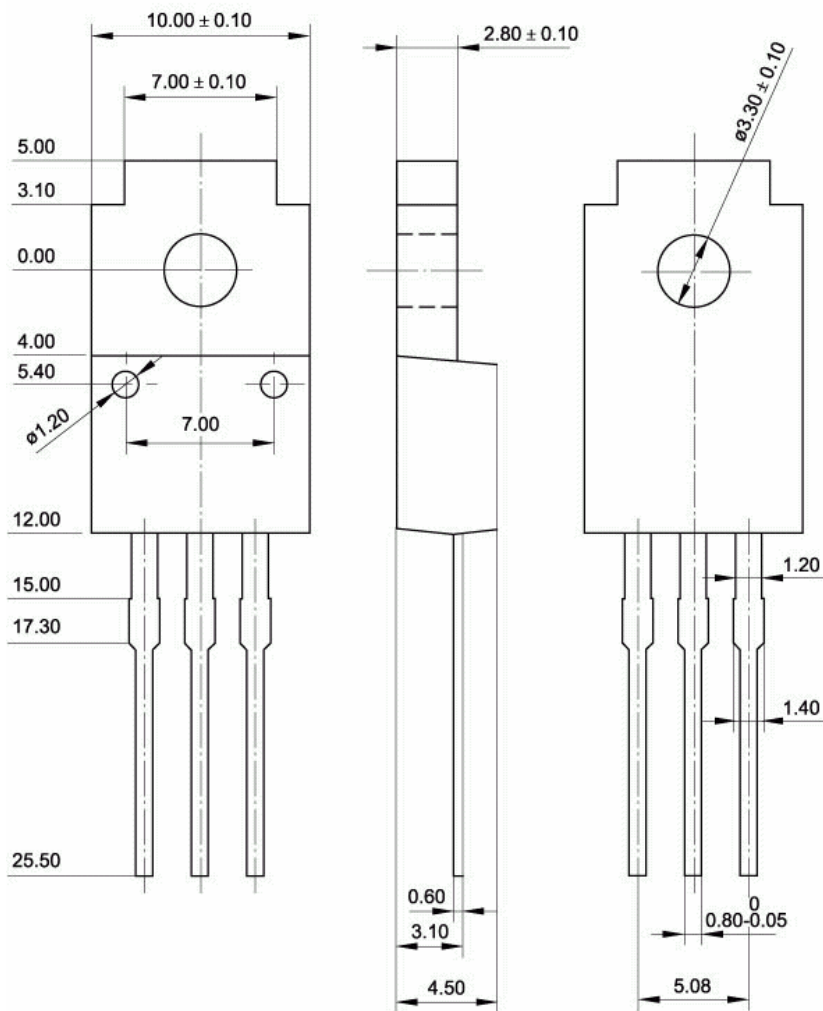

Fig.2 Outline dimensions (unindicated tolerance: ± 0.15 mm)