

**isc Silicon NPN Darlington Power Transistor**
**2SD1309**
**DESCRIPTION**

- High DC Current Gain  
:  $h_{FE} = 2000(\text{Min}) @ I_C = 3A$
- Collector-Emitter Sustaining Voltage-  
:  $V_{CEO(\text{SUS})} = 100V (\text{Min})$
- Low Collector-Emitter Saturation Voltage-  
:  $V_{CE(\text{sat})} = 1.5V (\text{Max}) @ I_C = 3A$
- Minimum Lot-to-Lot variations for robust device performance and reliable operation

**APPLICATIONS**

- Designed for audio frequency amplifier and low-speed switching industrial use.

**ABSOLUTE MAXIMUM RATINGS ( $T_a = 25^\circ\text{C}$ )**

SYMBOL	PARAMETER	VALUE	UNIT
$V_{CBO}$	Collector-Base Voltage	150	V
$V_{CEO}$	Collector-Emitter Voltage	100	V
$V_{EBO}$	Emitter-Base Voltage	7	V
$I_C$	Collector Current	8	A
$I_{CM}$	Collector Current-peak	12	A
$I_B$	Base Current	0.8	A
$P_C$	Collector Power Dissipation @ $T_c = 25^\circ\text{C}$	40	W
	Collector Power Dissipation @ $T_a = 25^\circ\text{C}$	1.5	
$T_j$	Junction Temperature	150	$^\circ\text{C}$
$T_{stg}$	Storage Temperature Range	-55~150	$^\circ\text{C}$

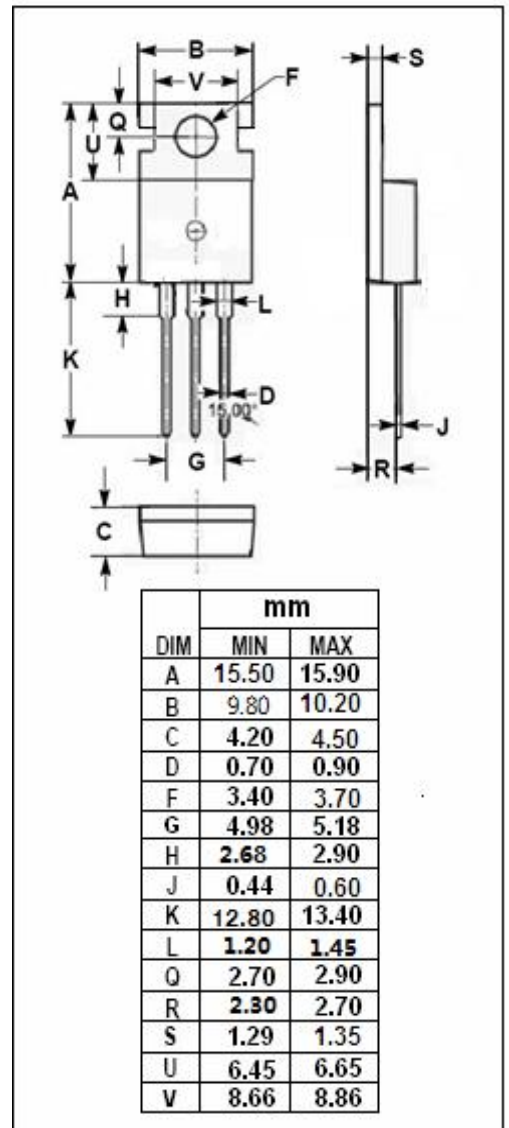
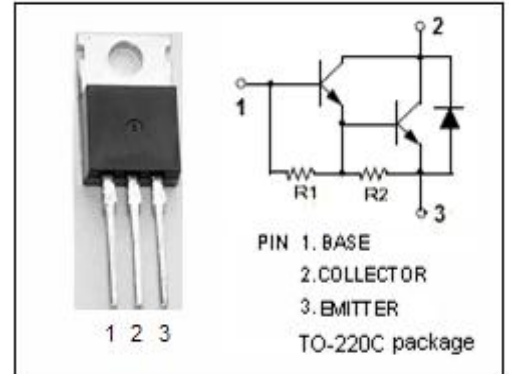

## isc Silicon NPN Darlington Power Transistor

2SD1309

## ELECTRICAL CHARACTERISTICS

T<sub>c</sub>=25°C unless otherwise specified

SYMBOL	PARAMETER	CONDITIONS	MIN	TYP.	MAX	UNIT
V <sub>CEO(SUS)</sub>	Collector-Emitter Sustaining Voltage	I <sub>C</sub> = 30mA; I <sub>B</sub> = 0	100			V
V <sub>CE(sat)</sub>	Collector-Emitter Saturation Voltage	I <sub>C</sub> = 3A; I <sub>B</sub> = 3mA			1.5	V
V <sub>BE(sat)</sub>	Base-Emitter Saturation Voltage	I <sub>C</sub> = 3A; I <sub>B</sub> = 3mA			2.0	V
I <sub>CBO</sub>	Collector Cutoff Current	V <sub>CB</sub> = 100V; I <sub>E</sub> = 0			1.0	μ A
I <sub>EBO</sub>	Emitter Cutoff Current	V <sub>EB</sub> = 5V; I <sub>C</sub> = 0			5	mA
h <sub>FE-1</sub>	DC Current Gain	I <sub>C</sub> = 3A; V <sub>CE</sub> = 2V	2000		15000	
h <sub>FE-2</sub>	DC Current Gain	I <sub>C</sub> = 5A; V <sub>CE</sub> = 2V	500			
t <sub>on</sub>	Turn-on Time			1.0		μ s
t <sub>stg</sub>	Storage Time	I <sub>C</sub> = 3A, R <sub>L</sub> = 16.7 Ω, I <sub>B1</sub> = I <sub>B2</sub> = 3mA, V <sub>CC</sub> ≈ 50V		3.5		μ s
t <sub>f</sub>	Fall Time			1.2		μ s

◆ h<sub>FE-1</sub> Classifications

M	L	K
2000-5000	3000-7000	5000-15000

**NOTICE:**

ISC reserves the rights to make changes of the content herein the datasheet at any time without notification. The information contained herein is presented only as a guide for the applications of our products.

ISC products are intended for usage in general electronic equipment. The products are not designed for use in equipment which require specialized quality and/or reliability, or in equipment which could have applications in hazardous environments, aerospace industry, or medical field. Please contact us if you intend our products to be used in these special applications.

ISC makes no warranty or guarantee regarding the suitability of its products for any particular purpose, nor does ISC assume any liability arising from the application or use of any products, and specifically disclaims any and all liability, including without limitation special, consequential or incidental damages.