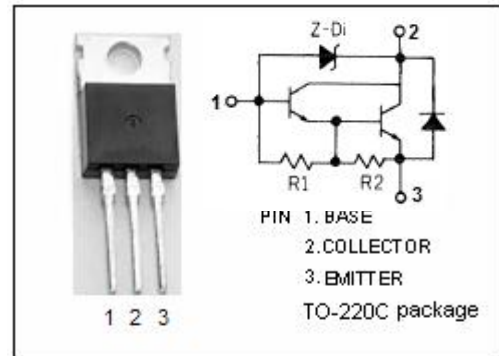

**isc Silicon NPN Darlington Power Transistor**
**2SD1395**
**DESCRIPTION**

- Collector-Emitter Breakdown Voltage-  
:  $V_{(BR)CEO} = 50V(\text{Min})$
- High DC Current Gain  
:  $h_{FE} = 1000(\text{Min}) @ I_C = 2.5A$
- Low Saturation Voltage
- Fast Switching Speed
- Minimum Lot-to-Lot variations for robust device performance and reliable operation

**APPLICATIONS**

- Designed for general purpose amplifier and low speed switching applications.

**ABSOLUTE MAXIMUM RATINGS( $T_a=25^\circ\text{C}$ )**

SYMBOL	PARAMETER	VALUE	UNIT
$V_{CBO}$	Collector-Base Voltage	50	V
$V_{CEO}$	Collector-Emitter Voltage	50	V
$V_{EBO}$	Emitter-Base Voltage	6	V
$I_C$	Collector Current-Continuous	5	A
$I_{CP}$	Collector Current-Peak	8	A
$P_C$	Collector Power Dissipation @ $T_C=25^\circ\text{C}$	40	W
$T_J$	Junction Temperature	150	$^\circ\text{C}$
$T_{stg}$	Storage Temperature Range	-55~150	$^\circ\text{C}$

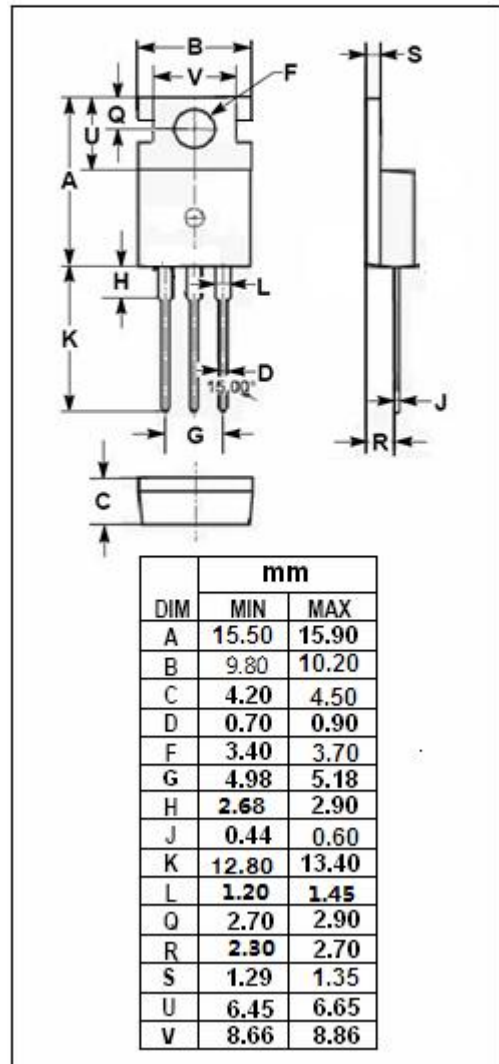

**isc Silicon NPN Darlington Power Transistor**
**2SD1395**
**ELECTRICAL CHARACTERISTICS**
 $T_C=25^\circ\text{C}$  unless otherwise specified

SYMBOL	PARAMETER	CONDITIONS	MIN	TYP.	MAX	UNIT
$V_{CE(SUS)}$	Collector-Emitter Sustaining Voltage	$I_C=50\text{mA}$ , $I_B=0$	50			V
$V_{CE(sat)}$	Collector-Emitter Saturation Voltage	$I_C=2.5\text{A}$ , $I_B=5\text{mA}$			1.5	V
$V_{BE(sat)}$	Base-Emitter Saturation Voltage	$I_C=2.5\text{A}$ , $I_B=5\text{mA}$			2.0	V
$I_{CBO}$	Collector Cutoff Current	$V_{CB}=50\text{V}$ , $I_E=0$			0.1	mA
$I_{CEO}$	Collector Cutoff Current	$V_{CE}=50\text{V}$ , $I_B=0$			1.0	mA
$I_{EBO}$	Emitter Cutoff Current	$V_{EB}=5\text{V}$ ; $I_C=0$			3.0	mA
$h_{FE}$	DC Current Gain	$I_C=2.5\text{A}$ ; $V_{CE}=3\text{V}$	1000		15000	
$f_T$	Current-Gain—Bandwidth Product	$I_C=2.5\text{A}$ ; $V_{CE}=5\text{V}$		20		MHz

## Switching Times

$t_{on}$	Turn-on Time	$I_C=3.0\text{A}$ ; $I_{B1}=I_{B2}=6\text{mA}$		0.6		$\mu\text{s}$
$t_s$	Storage Time			4.0		$\mu\text{s}$
$t_f$	Fall Time			1.5		$\mu\text{s}$

**NOTICE:**

ISC reserves the rights to make changes of the content herein the datasheet at any time without notification. The information contained herein is presented only as a guide for the applications of our products.

ISC products are intended for usage in general electronic equipment. The products are not designed for use in equipment which require specialized quality and/or reliability, or in equipment which could have applications in hazardous environments, aerospace industry, or medical field. Please contact us if you intend our products to be used in these special applications.

ISC makes no warranty or guarantee regarding the suitability of its products for any particular purpose, nor does ISC assume any liability arising from the application or use of any products, and specifically disclaims any and all liability, including without limitation special, consequential or incidental damages.