

Silicon NPN Power Transistors

2SD1453

DESCRIPTION

www.datasheet4u.com

- With TO-3PN package
- High voltage,high speed
- Built-in damper diode

APPLICATIONS

- For TV horizontal deflection output applications

PINNING

PIN	DESCRIPTION
1	Base
2	Collector;connected to mounting base
3	Emitter

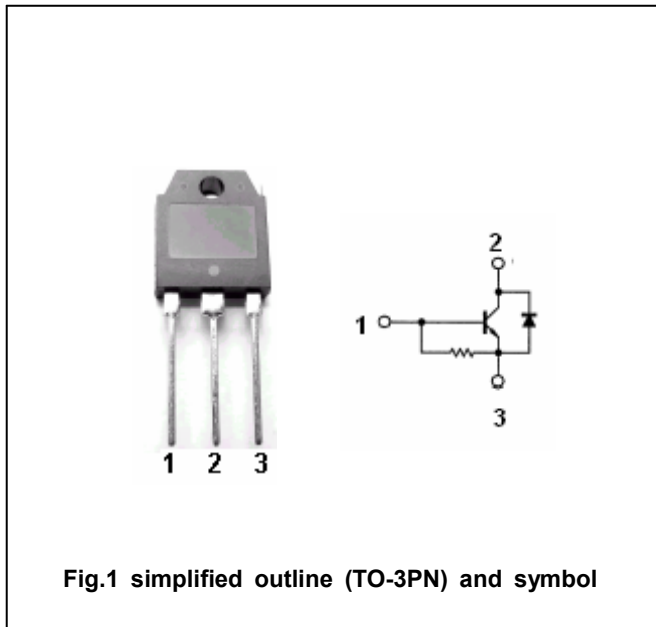

Fig.1 simplified outline (TO-3PN) and symbol

Absolute maximum ratings (Ta=25°C)

SYMBOL	PARAMETER	CONDITIONS	VALUE	UNIT
V _{CBO}	Collector-base voltage	Open emitter	1500	V
V _{EBO}	Emitter-base voltage	Open collector	6	V
I _C	Collector current (DC)		3	A
I _{CM}	Collector current-Peak		3.5	A
P _C	Collector power dissipation	T _C =25°C	50	W
T _j	Junction temperature		150	°C
T _{stg}	Storage temperature		-45~150	°C

Silicon NPN Power Transistors

2SD1453

CHARACTERISTICS

T_j=25°C unless otherwise specified

www.datasheet4u.com

SYMBOL	PARAMETER	CONDITIONS	MIN	TYP.	MAX	UNIT
V _{(BR)EBO}	Emitter-base breakdown voltage	I _E =200mA; I _C =0	6			V
V _{CEsat}	Collector-emitter saturation voltage	I _C =2.5A; I _B =0.8A			5.0	V
V _{BEsat}	Base-emitter saturation voltage	I _C =2.5A; I _B =0.8A			1.5	V
I _{CES}	Collector cut-off current	V _{CE} =1500V; R _{BE} =∞			0.5	mA
h _{FE}	DC current gain	I _C =0.3A ; V _{CE} =5V	6			
V _F	Diode forward voltage	I _F =3A			2.2	V
t _f	Fall time	I _{CP} =2.75A; I _{B1} =0.6A; I _{B2} ≈-1.3A			0.8	μs

Silicon NPN Power Transistors

2SD1453

PACKAGE OUTLINE

www.datasheet4u.com

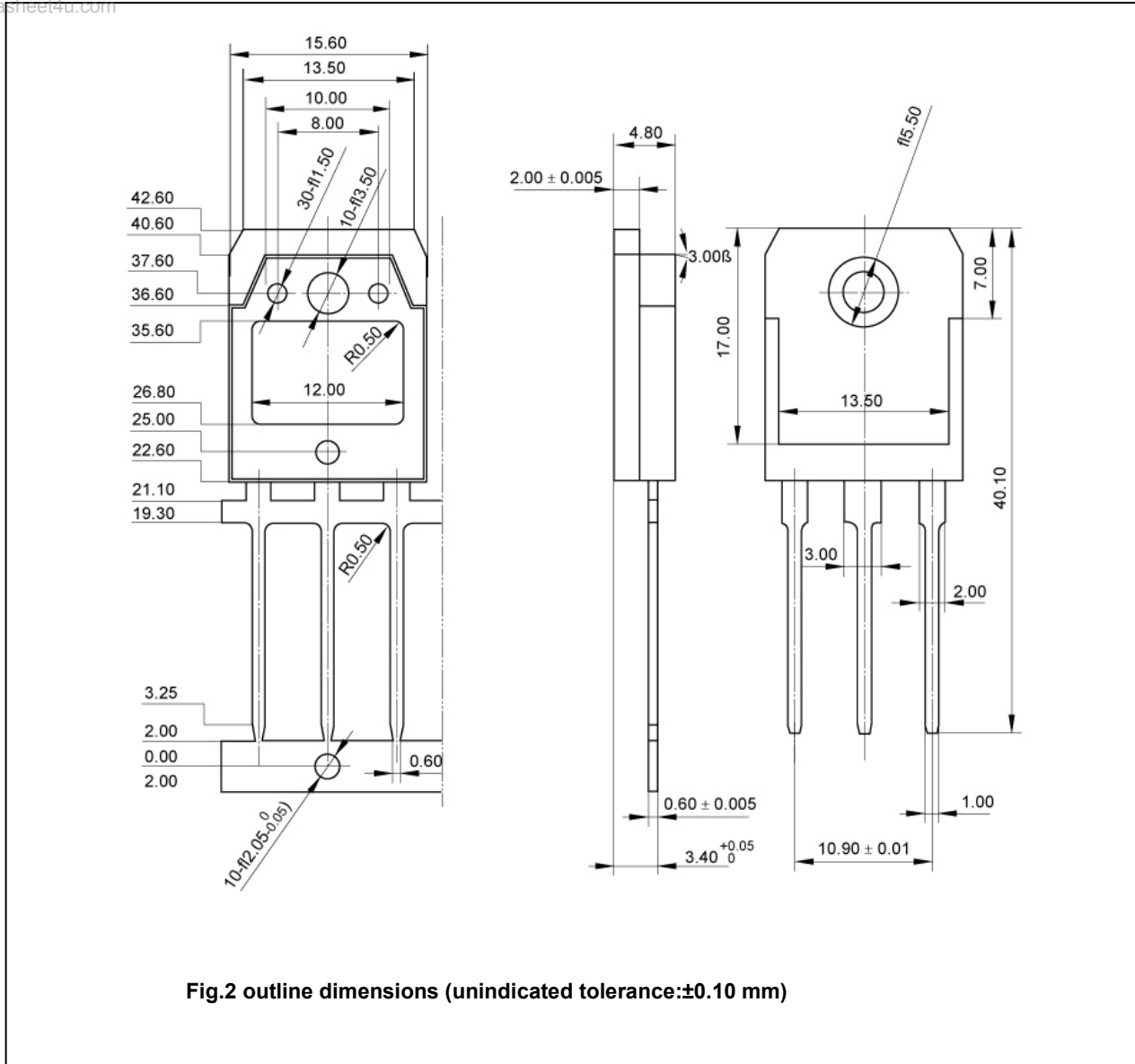

Fig.2 outline dimensions (unindicated tolerance: ± 0.10 mm)