

Silicon NPN Power Transistors

2SD1547

DESCRIPTION

www.datasheet4u.com

- With TO-3P(H)IS package
- High voltage ,high speed
- Low collector saturation voltage

APPLICATIONS

- Color TV horizontal output applications
- Switching regulator output applications

PINNING

PIN	DESCRIPTION
1	Base
2	Collector
3	Emitter

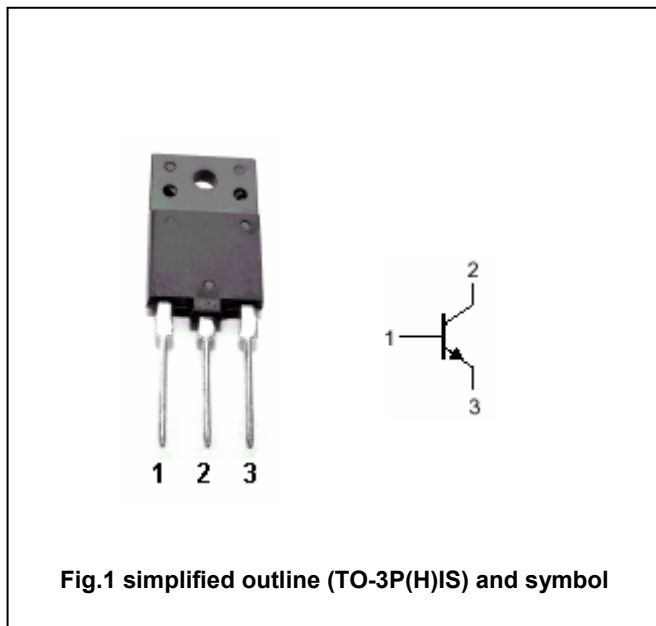

Fig.1 simplified outline (TO-3P(H)IS) and symbol

Absolute maximum ratings (Ta=25°C)

SYMBOL	PARAMETER	CONDITIONS	VALUE	UNIT
V <sub>CBO</sub>	Collector-base voltage	Open emitter	1500	V
V <sub>CEO</sub>	Collector-emitter voltage	Open base	600	V
V <sub>EBO</sub>	Emitter-base voltage	Open collector	5	V
I <sub>C</sub>	Collector current		7	A
I <sub>B</sub>	Base current		3.5	A
P <sub>C</sub>	Collector power dissipation	T <sub>C</sub> =25°C	50	W
T <sub>j</sub>	Junction temperature		150	°C
T <sub>stg</sub>	Storage temperature		-55~150	°C

## Silicon NPN Power Transistors

## 2SD1547

## CHARACTERISTICS

T<sub>j</sub>=25°C unless otherwise specified

www.datasheet4u.com

SYMBOL	PARAMETER	CONDITIONS	MIN	TYP.	MAX	UNIT
V <sub>CEsat</sub>	Collector-emitter saturation voltage	I <sub>C</sub> =6A ; I <sub>B</sub> =1.2A		3.0	5.0	V
V <sub>BEsat</sub>	Base-emitter saturation voltage	I <sub>C</sub> =6A ; I <sub>B</sub> =1.2A			1.5	V
I <sub>CB0</sub>	Collector cut-off current	V <sub>CB</sub> =500V; I <sub>E</sub> =0			10	μA
I <sub>EB0</sub>	Emitter cut-off current	V <sub>EB</sub> =5V; I <sub>C</sub> =0			1	mA
h <sub>FE</sub>	DC current gain	I <sub>C</sub> =1A ; V <sub>CE</sub> =5V	8	20		
f <sub>T</sub>	Transition frequency	I <sub>C</sub> =0.1A ; V <sub>CE</sub> =10V		3		MHz
C <sub>OB</sub>	Collector output capacitance	I <sub>E</sub> =0 ; V <sub>CB</sub> =10V; f=1MHz		165		pF
t <sub>f</sub>	Fall time	I <sub>CP</sub> =6A ; I <sub>B1(end)</sub> =1.2A		0.5	1.0	μs

Silicon NPN Power Transistors

2SD1547

PACKAGE OUTLINE

www.datasheet4u.com

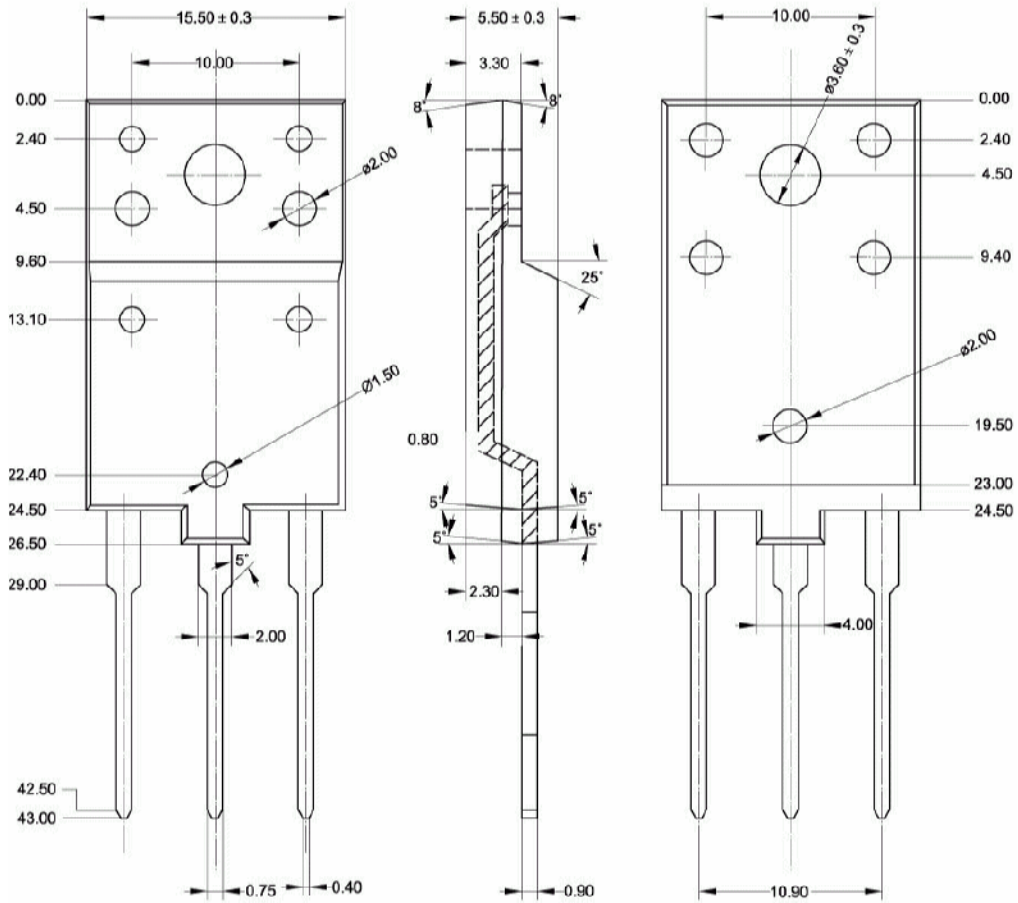

Fig.2 Outline dimensions (unindicated tolerance:±0.15 mm)