

isc Silicon NPN Darlington Power Transistor

2SD1756

DESCRIPTION

- Collector-Emitter Sustaining Voltage-
: $V_{CEO(SUS)} = 170V(\text{Min})$
- High DC Current Gain
: $h_{FE} = 1500(\text{Min}) @ I_C = 5A$
- Low Collector Saturation Voltage
- Minimum Lot-to-Lot variations for robust device performance and reliable operation

APPLICATIONS

- Designed for high voltage high current amplifier applications.

ABSOLUTE MAXIMUM RATINGS($T_a = 25^\circ\text{C}$)

SYMBOL	PARAMETER	VALUE	UNIT
V_{CBO}	Collector-Base Voltage	200	V
V_{CEO}	Collector-Emitter Voltage	200	V
V_{EBO}	Emitter-Base Voltage	7	V
I_C	Collector Current-Continuous	10	A
I_{CP}	Collector Current-Peak	15	A
P_C	Collector Power Dissipation @ $T_C = 25^\circ\text{C}$	40	W
T_J	Junction Temperature	150	$^\circ\text{C}$
T_{stg}	Storage Temperature Range	-55~150	$^\circ\text{C}$

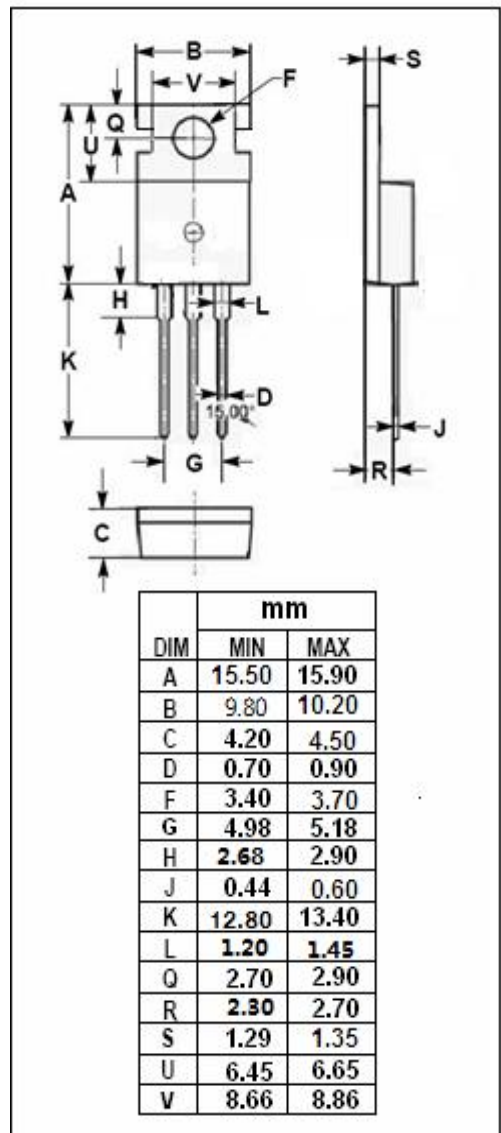
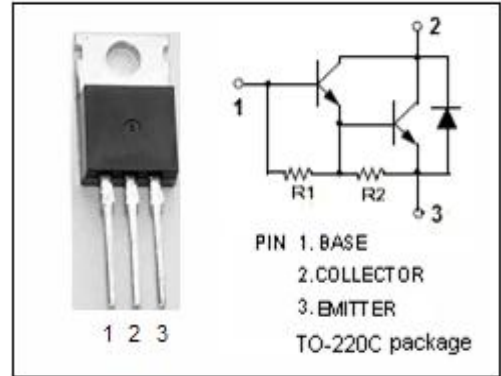

isc Silicon NPN Darlington Power Transistor

2SD1756

ELECTRICAL CHARACTERISTICS

 $T_C=25^{\circ}\text{C}$ unless otherwise specified

SYMBOL	PARAMETER	CONDITIONS	MIN	TYP.	MAX	UNIT
$V_{CEO(SUS)}$	Collector-Emitter Sustaining Voltage	$I_C=5\text{A}; L=5\text{mH}$	170			V
$V_{(BR)CEO}$	Collector-Emitter Breakdown Voltage	$I_C=25\text{mA}; R_{BE}=\infty$	200			V
$V_{(BR)EBO}$	Emitter-Base Breakdown Voltage	$I_E=5\text{mA}; I_C=0$	7			V
$V_{CE(sat)-1}$	Collector-Emitter Saturation Voltage	$I_C=5\text{A}; I_B=10\text{mA}$			1.5	V
$V_{CE(sat)-2}$	Collector-Emitter Saturation Voltage	$I_C=10\text{A}; I_B=100\text{mA}$			3.5	V
$V_{BE(sat)-1}$	Base-Emitter Saturation Voltage	$I_C=5\text{A}; I_B=10\text{mA}$			2.0	V
$V_{BE(sat)-2}$	Base-Emitter Saturation Voltage	$I_C=10\text{A}; I_B=100\text{mA}$			4.0	V
I_{CEO}	Collector Cutoff Current	$V_{CE}=180\text{V}; R_{BE}=\infty$			500	μA
h_{FE}	DC Current Gain	$I_C=5\text{A}; V_{CE}=3\text{V}$	1500			

Switching times

t_{on}	Turn-on Time			0.9		μs
t_{stg}	Storage Time	$I_C=5\text{A}, I_{B1}=I_{B2}=10\text{mA}; V_{CC}=30\text{V}$		8.0		μs
t_f	Fall Time			3.5		μs

NOTICE:

ISC reserves the rights to make changes of the content herein the datasheet at any time without notification. The information contained herein is presented only as a guide for the applications of our products.

ISC products are intended for usage in general electronic equipment. The products are not designed for use in equipment which require specialized quality and/or reliability, or in equipment which could have applications in hazardous environments, aerospace industry, or medical field. Please contact us if you intend our products to be used in these special applications.

ISC makes no warranty or guarantee regarding the suitability of its products for any particular purpose, nor does ISC assume any liability arising from the application or use of any products, and specifically disclaims any and all liability, including without limitation special, consequential or incidental damages.