

## NPN Transistors

### 2SD1760

#### ■ Features

- Low  $V_{CE(sat)}$
- Complementary to 2SB1184

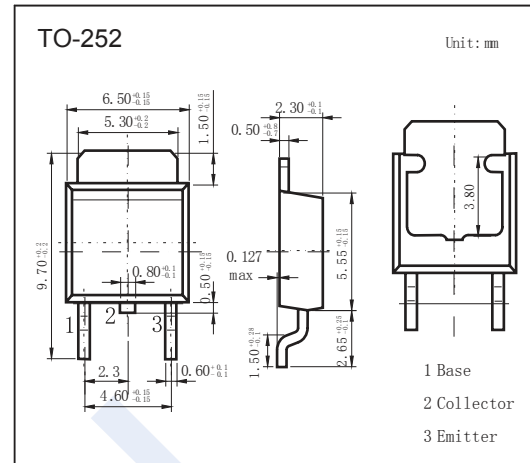

#### ■ Absolute Maximum Ratings $T_a = 25^\circ\text{C}$

Parameter	Symbol	Rating	Unit
Collector - Base Voltage	$V_{CB0}$	60	V
Collector - Emitter Voltage	$V_{CE0}$	50	
Emitter - Base Voltage	$V_{EB0}$	5	
Collector Current - Continuous	$I_C$	3	A
Collector Current - Pulse	$I_{CP}$	4.5	
Collector Power Dissipation $T_c=25^\circ\text{C}$	$P_C$	15	W
Junction Temperature	$T_J$	150	$^\circ\text{C}$
Storage Temperature Range	$T_{stg}$	-55 to 150	

#### ■ Electrical Characteristics $T_a = 25^\circ\text{C}$

Parameter	Symbol	Test Conditions	Min	Typ	Max	Unit
Collector- base breakdown voltage	$V_{CB0}$	$I_C = 100 \mu\text{A}$ , $I_E = 0$	60			V
Collector- emitter breakdown voltage	$V_{CE0}$	$I_C = 1 \text{ mA}$ , $I_B = 0$	50			
Emitter - base breakdown voltage	$V_{EB0}$	$I_E = 100 \mu\text{A}$ , $I_C = 0$	5			
Collector-base cut-off current	$I_{CB0}$	$V_{CB} = 50 \text{ V}$ , $I_E = 0$			1	$\mu\text{A}$
Emitter cut-off current	$I_{EB0}$	$V_{EB} = 4 \text{ V}$ , $I_C = 0$			1	
Collector-emitter saturation voltage	$V_{CE(sat)}$	$I_C = 2 \text{ A}$ , $I_B = 200 \text{ mA}$		0.5	1	V
Base - emitter saturation voltage	$V_{BE(sat)}$	$I_C = 2 \text{ A}$ , $I_B = 200 \text{ mA}$			1.2	
DC current gain	$h_{FE}$	$V_{CE} = 3 \text{ V}$ , $I_C = 500 \text{ mA}$	120		390	
Collector Output capacitance	$C_{ob}$	$V_{CB} = 10 \text{ V}$ , $I_E = 0$ , $f = 1 \text{ MHz}$		40		$\mu\text{F}$
Transition frequency	$f_T$	$V_{CE} = 5 \text{ V}$ , $I_E = -500 \text{ mA}$ , $f = 30 \text{ MHz}$		90		MHz

#### ■ Classification of $h_{FE}$

Type	2SD1760-Q	2SD1760-R
Range	120-270	180-390

# NPN Transistors

## 2SD1760

■ Typical Characteristics

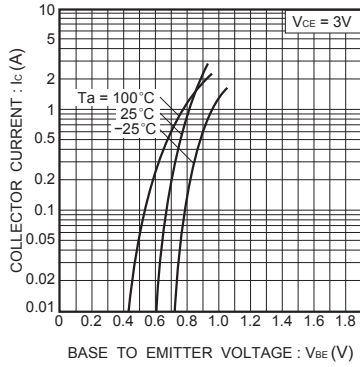

Fig.1 Grounded emitter propagation characteristics

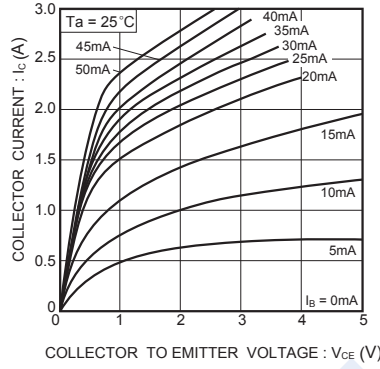

Fig.2 Grounded emitter output characteristics (1)

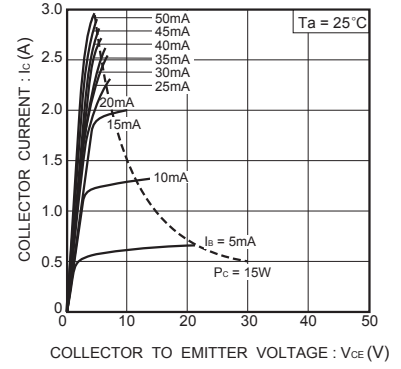

Fig.3 Grounded-emitter output characteristics (2)

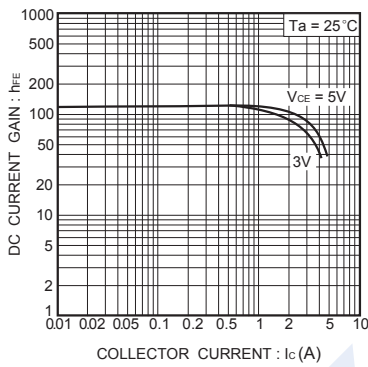

Fig.4 DC current gain vs. collector current(1)

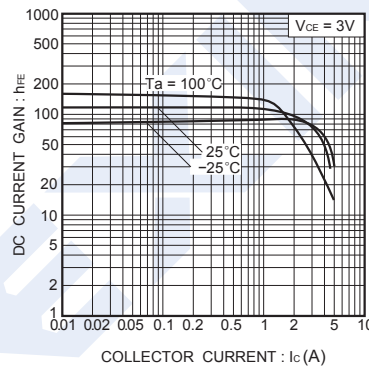

Fig.5 DC current gain vs. collector current(2)

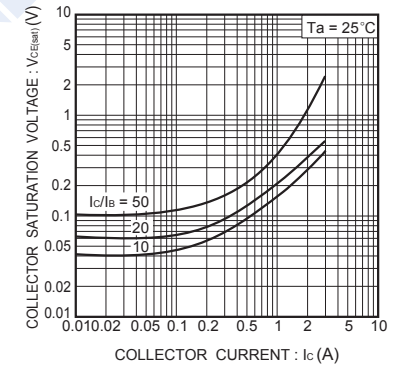

Fig.6 Collector-emitter saturation voltage vs. collector current

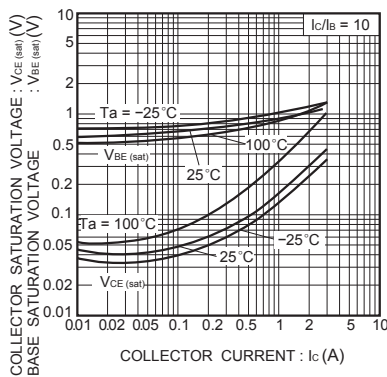

Fig.7 Collector-emitter saturation voltage vs. collector current  
Base-emitter saturation voltage vs. collector current

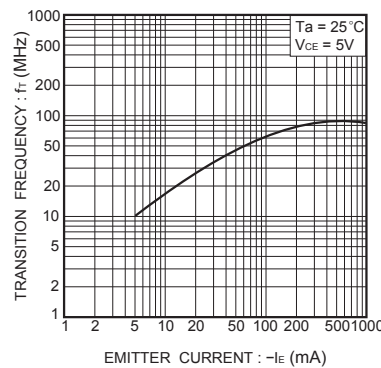

Fig.8 Gain bandwidth product vs. emitter current

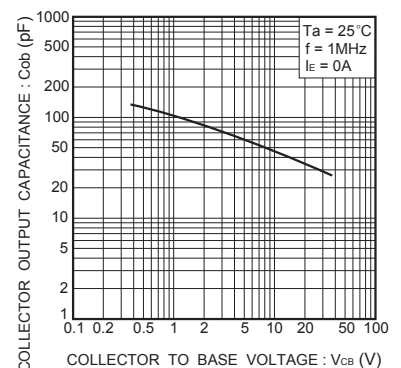

Fig.9 Collector output capacitance vs. collector-base voltage

## NPN Transistors

### 2SD1760

#### ■ Typical Characteristics

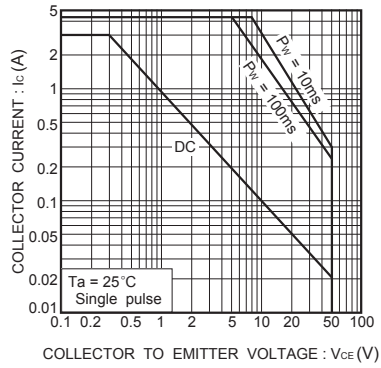

Fig.10 Safe operating area

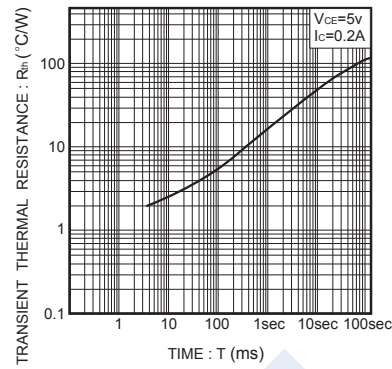

Fig.11 Transient thermal resistance