

Silicon NPN Power Transistors

2SD2014

DESCRIPTION

www.datasheet4u.com

- With TO-220F package
- DARLINGTON
- Complement to type 2SB1257

APPLICATIONS

- Driver for solenoid,relay and motor, series regulator,and general purpose applications

PINNING

PIN	DESCRIPTION
1	Base
2	Collector
3	Emitter

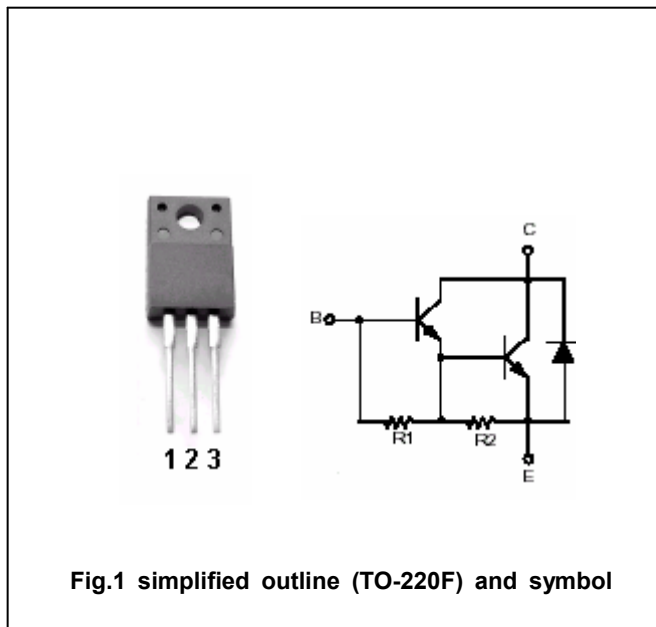

Fig.1 simplified outline (TO-220F) and symbol

Absolute maximum ratings (Ta=25°C)

SYMBOL	PARAMETER	CONDITIONS	VALUE	UNIT
V <sub>CBO</sub>	Collector-base voltage	Open emitter	120	V
V <sub>CEO</sub>	Collector-emitter voltage	Open base	80	V
V <sub>EBO</sub>	Emitter-base voltage	Open collector	6	V
I <sub>C</sub>	Collector current		4	A
I <sub>B</sub>	Base current		0.5	A
P <sub>C</sub>	Collector dissipation	T <sub>C</sub> =25°C	25	W
T <sub>j</sub>	Junction temperature		150	°C
T <sub>stg</sub>	Storage temperature		-55~150	°C

## Silicon NPN Power Transistors

## 2SD2014

## CHARACTERISTICS

T<sub>j</sub>=25°C unless otherwise specified

www.datasheet4u.com

SYMBOL	PARAMETER	CONDITIONS	MIN	TYP.	MAX	UNIT
V <sub>(BR)CEO</sub>	Collector-emitter breakdown voltage	I <sub>C</sub> =10mA ; I <sub>B</sub> =0	80			V
V <sub>CEsat</sub>	Collector-emitter saturation voltage	I <sub>C</sub> =3A ; I <sub>B</sub> =3mA			1.5	V
V <sub>BEsat</sub>	Base-emitter saturation voltage	I <sub>C</sub> =3A ; I <sub>B</sub> =3mA			2.0	V
I <sub>CBO</sub>	Collector cut-off current	V <sub>CB</sub> =120V; I <sub>E</sub> =0			10	μA
I <sub>EBO</sub>	Emitter cut-off current	V <sub>EB</sub> =6V; I <sub>C</sub> =0			10	mA
h <sub>FE</sub>	DC current gain	I <sub>C</sub> =3A ; V <sub>CE</sub> =2V	2000			
f <sub>T</sub>	Transition frequency	I <sub>E</sub> =-0.1A ; V <sub>CE</sub> =12V		75		MHz
C <sub>OB</sub>	Collector output capacitance	f=1MHz; V <sub>CB</sub> =10V		45		pF

## Switching times

t <sub>on</sub>	Turn-on time	I <sub>C</sub> =3.0A; I <sub>B1</sub> =-I <sub>B2</sub> =10mA V <sub>CC</sub> =30V , R <sub>L</sub> =10Ω		1.0		μs
t <sub>s</sub>	Storage time			4.0		μs
t <sub>f</sub>	Fall time			1.5		μs

Silicon NPN Power Transistors

2SD2014

PACKAGE OUTLINE

www.datasheet4u.com

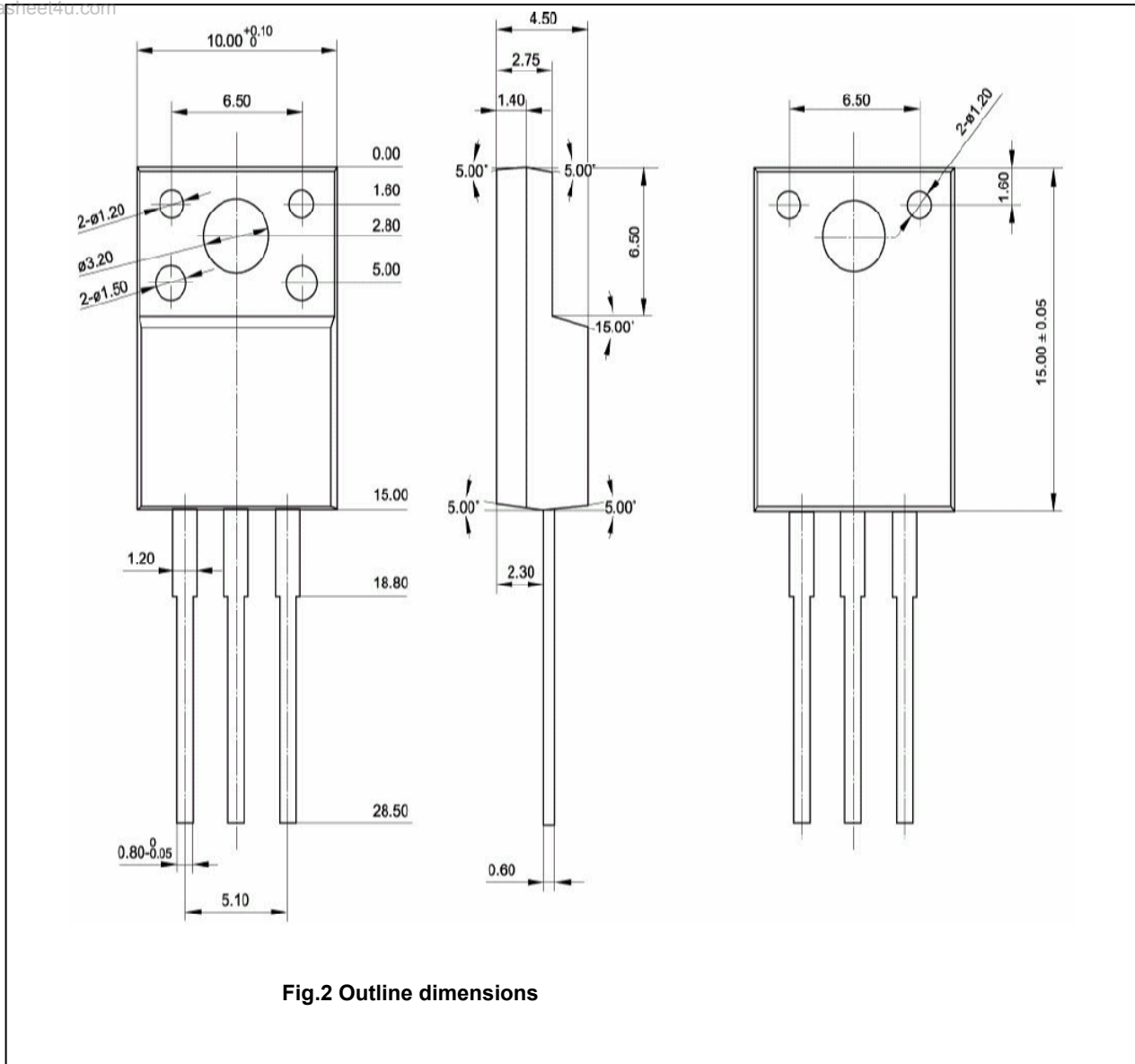

Fig.2 Outline dimensions