

isc Silicon NPN Darlington Power Transistor

2SD2102

**DESCRIPTION**

- Collector-Emitter Breakdown Voltage-  
:  $V_{(BR)CEO} = 60V(\text{Min})$
- High DC Current Gain  
:  $h_{FE} = 1000(\text{Min}) @ I_C = 2A, V_{CE} = 3V$

**APPLICATIONS**

- Designed for low frequency power amplifier applications

**ABSOLUTE MAXIMUM RATINGS( $T_a=25^\circ\text{C}$ )**

SYMBOL	PARAMETER	VALUE	UNIT
$V_{CBO}$	Collector-Base Voltage	60	V
$V_{CEO}$	Collector-Emitter Voltage	60	V
$V_{EBO}$	Emitter-Base Voltage	7	V
$I_C$	Collector Current-Continuous	4	A
$I_{CM}$	Base Current-Peak	8	A
$P_C$	Collector Power Dissipation @ $T_a=25^\circ\text{C}$	2	W
	Collector Power Dissipation @ $T_c=25^\circ\text{C}$	25	
$T_J$	Junction Temperature	150	$^\circ\text{C}$
$T_{stg}$	Storage Temperature Range	-55~150	$^\circ\text{C}$

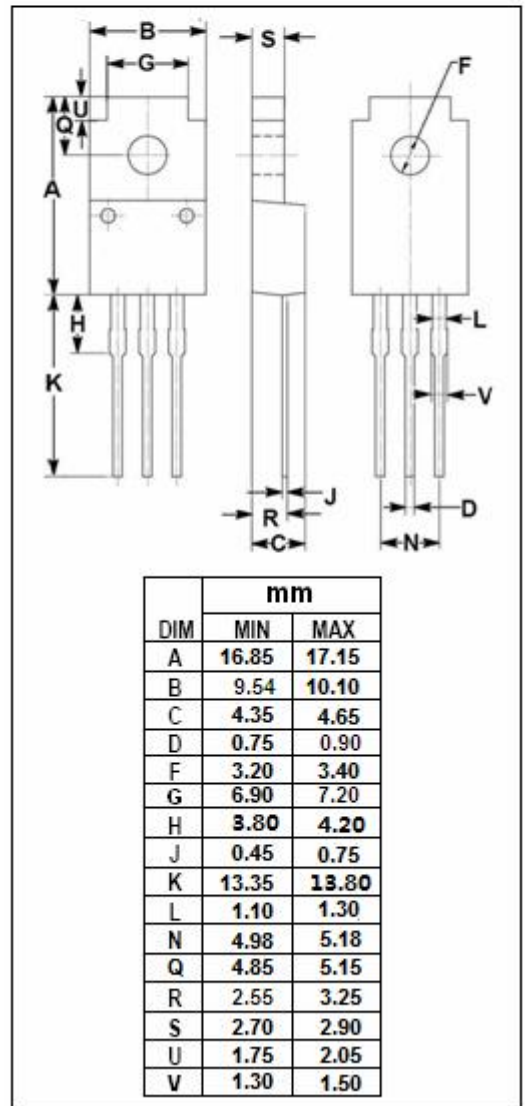
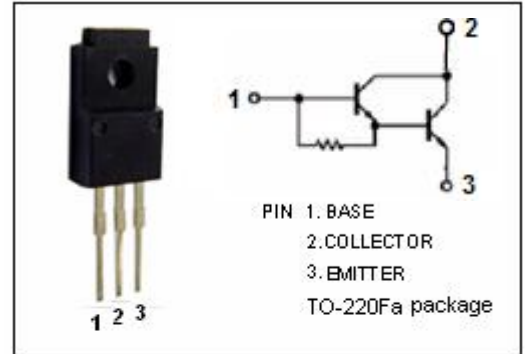

**isc Silicon NPN Darlington Power Transistor****2SD2102****ELECTRICAL CHARACTERISTICS****T<sub>c</sub>=25°C unless otherwise specified**

SYMBOL	PARAMETER	CONDITIONS	MIN	TYP.	MAX	UNIT
V <sub>(BR)CEO</sub>	Collector-Emitter Breakdown Voltage	I <sub>C</sub> = 25mA ; R <sub>BE</sub> = ∞	60			V
V <sub>(BR)CBO</sub>	Collector-Base Breakdown Voltage	I <sub>C</sub> = 0.1mA; I <sub>E</sub> = 0	60			V
V <sub>(BR)EBO</sub>	Emitter-Base Breakdown Voltage	I <sub>E</sub> = 50mA; I <sub>C</sub> = 0	7			V
V <sub>CE(sat)-1</sub>	Collector-Emitter Saturation Voltage	I <sub>C</sub> = 2A; I <sub>B</sub> = 4mA			1.5	V
V <sub>CE(sat)-2</sub>	Collector-Emitter Saturation Voltage	I <sub>C</sub> = 4A; I <sub>B</sub> = 40mA			3.0	V
V <sub>BE(sat)-1</sub>	Base-Emitter Saturation Voltage	I <sub>C</sub> = 2A; I <sub>B</sub> = 4mA			2.0	V
V <sub>BE(sat)-2</sub>	Base-Emitter Saturation Voltage	I <sub>C</sub> = 4A; I <sub>B</sub> = 40mA			3.5	V
I <sub>CBO</sub>	Collector Cutoff Current	V <sub>CB</sub> = 50V; I <sub>E</sub> = 0			10	μ A
I <sub>CEO</sub>	Collector Cutoff Current	V <sub>CE</sub> = 50V; R <sub>BE</sub> = ∞			10	μ A
h <sub>FE</sub>	DC Current Gain	I <sub>C</sub> = 2A ; V <sub>CE</sub> = 3V	1000		20000	